



TECHNICAL DIAGRAMS

ALTO-SHAAM®

500-S 750-S 1000-S 1200-S
1000-UP 1200-UP

01706 353 633

WWW.FOODSERVICESPARES.COM

SPARE PARTS DIAGRAM FOR



Holding Cabinet

500-S

750-S

1000-S

1200-S

1000-UP

1200-UP

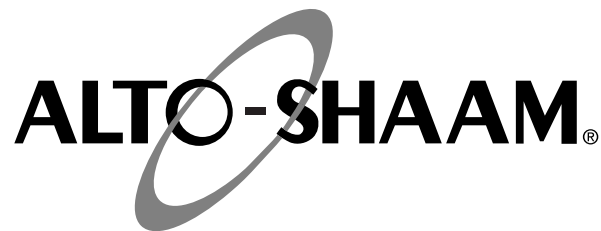

Delivery	1
Unpacking	1
Safety Procedures and Precautions	2

Installation

Installation Requirements	3
Clearance Requirements	3
Dimension Drawings, weights & capacities	4-6
Options and Accessories	7
Universal Pan Slides/Side Racks and Shelves	8
Leveling	9
Restraint Requirements - Mobile Equipment	9
Drip Tray Installation	10
Electrical Specifications	11-12
User Safety Information	13
Before Initial Use	13
Heating Characteristics	13

Operating Instructions

Simple Control Operation	14
Deluxe Control Identification	15
Deluxe Control Set-Up	15
Deluxe Control Operation	15
Heat Recovery	16
Dough Proofing Instructions	16
Deluxe Control Timer Programming	17
General Holding Guidelines	18

Care and Cleaning

Cleaning and Preventative Maintenance	19
Protecting Stainless Steel Surfaces	19
Cleaning Agents	19
Cleaning Materials	19
Clean Daily	20

Sanitation

Sanitation/Food Safety	21
Internal Food Product Temperatures	21

Service

Thermostat Accuracy	22
Trouble Shooting	23
Exterior Service Views and Parts - SIMPLE CONTROL	
SINGLE COMPARTMENT	24-25
DOUBLE COMPARTMENT	26-27
Exterior Service Views and Parts - DELUXE CONTROL	
SINGLE COMPARTMENT	28-29
DOUBLE COMPARTMENT	30-31
Cable Heating Kits	32

Wire Diagrams

500, 750, 1000, 1200-S - SIMPLE CONTROL	
120V	33
208-240V	34
230V	35
500, 750, 1000, 1200-S - DELUXE CONTROL	
120V	36
208-240V	37
230V	38
1000-UP and 1200-UP - SIMPLE CONTROL	
120V	39
208-240V	40
230V	41
1000-UP and 1200-UP - DELUXE CONTROL	
1000-UP - 120V	42
208-240V	43
1000-UP - 230V	44
1200-UP - 120V	45
208-240V	46
230V	47

Warranty

Transportation Damage and Claims	Back Cover
Limited Warranty	Back Cover

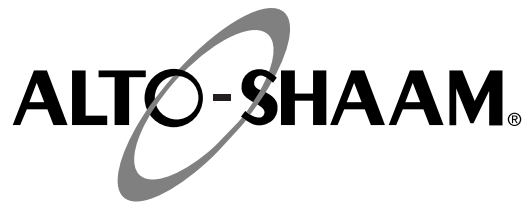

DELIVERY

This Alto-Shaam appliance has been thoroughly tested and inspected to ensure only the highest quality unit is provided. Upon receipt, check for any possible shipping damage and report it at once to the delivering carrier. *See Transportation Damage and Claims section located in this manual.*

This appliance, complete with unattached items and accessories, may have been delivered in one or more packages. Check to ensure that all standard items and options have been received with each model as ordered.

Save all the information and instructions packed with the appliance. Complete and return the warranty card to the factory as soon as possible to ensure prompt service in the event of a warranty parts and labor claim.

This manual must be read and understood by all people using or installing the equipment model. Contact the Alto-Shaam Tech Team Service Department if you have any questions concerning installation, operation, or maintenance.

NOTE: All claims for warranty must include the full model number and serial number of the unit.

UNPACKING

1. Carefully remove the appliance from the carton or crate.

NOTE: Do not discard the carton and other packaging material until you have inspected the unit for hidden damage and tested it for proper operation.

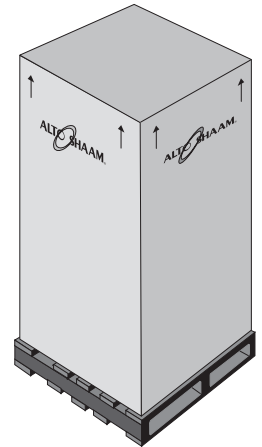

2. Read all instructions in this manual carefully before initiating the installation of this appliance.

DO NOT DISCARD THIS MANUAL.

This manual is considered to be part of the appliance and is to be provided to the owner or manager of the business or to the person responsible for training operators. *Additional manuals are available from the Alto-Shaam Tech Team Service Department.*

3. Remove all protective plastic film, packaging materials, and accessories from the appliance before connecting electrical power. Store any accessories in a convenient place for future use.

SAFETY PROCEDURES AND PRECAUTIONS

Knowledge of proper procedures is essential to the safe operation of electrically and/or gas energized equipment. In accordance with generally accepted product safety labeling guidelines for potential hazards, the following signal words and symbols may be used throughout this manual.

DANGER	
	Used to indicate the presence of a hazard that WILL cause severe personal injury, death, or substantial property damage if the warning included with this symbol is ignored.

WARNING	
	Used to indicate the presence of a hazard that CAN cause personal injury, possible death, or major property damage if the warning included with this symbol is ignored.

CAUTION	
	Used to indicate the presence of a hazard that can or will cause minor or moderate personal injury or property damage if the warning included with this symbol is ignored.

CAUTION	
Used to indicate the presence of a hazard that can or will cause minor personal injury, property damage, or a potential unsafe practice if the warning included with this symbol is ignored.	

NOTE: Used to notify personnel of installation, operation, or maintenance information that is important but not hazard related.
--

1. This appliance is intended to cook, hold or process foods for the purpose of human consumption. No other use for this appliance is authorized or recommended.
2. This appliance is intended for use in commercial establishments where all operators are familiar with the purpose, limitations, and associated hazards of this appliance. Operating instructions and warnings must be read and understood by all operators and users.
3. Any troubleshooting guides, component views, and parts lists included in this manual are for general reference only and are intended for use by qualified technical personnel.
4. This manual should be considered a permanent part of this appliance. This manual and all supplied instructions, diagrams, schematics, parts lists, notices, and labels must remain with the appliance if the item is sold or moved to another location.

NOTE	
	For equipment delivered for use in any location regulated by the following directive: DO NOT DISPOSE OF ELECTRICAL OR ELECTRONIC EQUIPMENT WITH OTHER MUNICIPAL WASTE.

INSTALLATION

DANGER



IMPROPER INSTALLATION, ALTERATION, ADJUSTMENT, SERVICE, OR MAINTENANCE COULD RESULT IN SEVERE INJURY, DEATH, OR CAUSE PROPERTY DAMAGE.

READ THE INSTALLATION, OPERATING AND MAINTENANCE INSTRUCTIONS THOROUGHLY BEFORE INSTALLING OR SERVICING THIS EQUIPMENT.

CAUTION



TO PREVENT PERSONAL INJURY, USE CAUTION WHEN MOVING OR LEVELING THIS APPLIANCE.

CAUTION



METAL PARTS OF THIS EQUIPMENT BECOME EXTREMELY HOT WHEN IN OPERATION. TO AVOID BURNS, ALWAYS USE HAND PROTECTION WHEN OPERATING THIS APPLIANCE.



DANGER



DO NOT store or use gasoline or other flammable vapors or liquids in the vicinity of this or any other appliance.

SITE INSTALLATION

The Alto-Shaam Holding Cabinet must be installed in a location that will permit the oven to function for its intended purpose and to allow adequate clearance for ventilation, proper cleaning, and maintenance access.

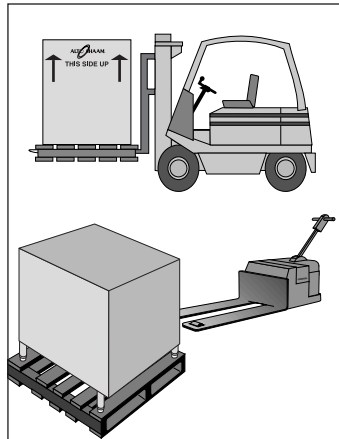

1. The oven must be installed on a stable and level surface.
2. **DO NOT** install this appliance in any area where it may be affected by any adverse conditions such as steam, grease, dripping water, high temperatures, or any other severely adverse conditions.
3. **DO NOT** store or use any flammable liquids or allow flammable vapors in the vicinity of this oven or any other appliance.
4. This appliance must be kept free and clear of any combustible materials.
5. This appliance must be kept free and clear of any obstructions blocking access for maintenance or service.

Emissions testing conducted by Underwriters Laboratories, Inc.® was found to be in compliance with the applicable requirements of NFPA96: 2004 Edition, Par. 4.1.1.2. U.L emissions sampling of grease laden vapor resulted in a total of 0.55 milligrams per cubic meter with no visible smoke and is considered representative of all oven models in the line. Based on these results, hood installation and/or outside venting should not be a requirement in most areas. Verify local codes for locations where more restrictive codes are applicable.

MINIMUM CLEARANCE REQUIREMENTS

BACK	3" (76mm)
LEFT SIDE	1" (25mm)
RIGHT SIDE	1" (25mm)
TOP	2" (51mm)

NOTE

If the appliance has been unplugged for an extended period of time, the Real Time Clock may require recharging. Turn main breaker to the unit off for 10 seconds and then restore power. For more information, see Error Code E-60 in the Troubleshooting section of this manual.

INSTALLATION

Model 500-S

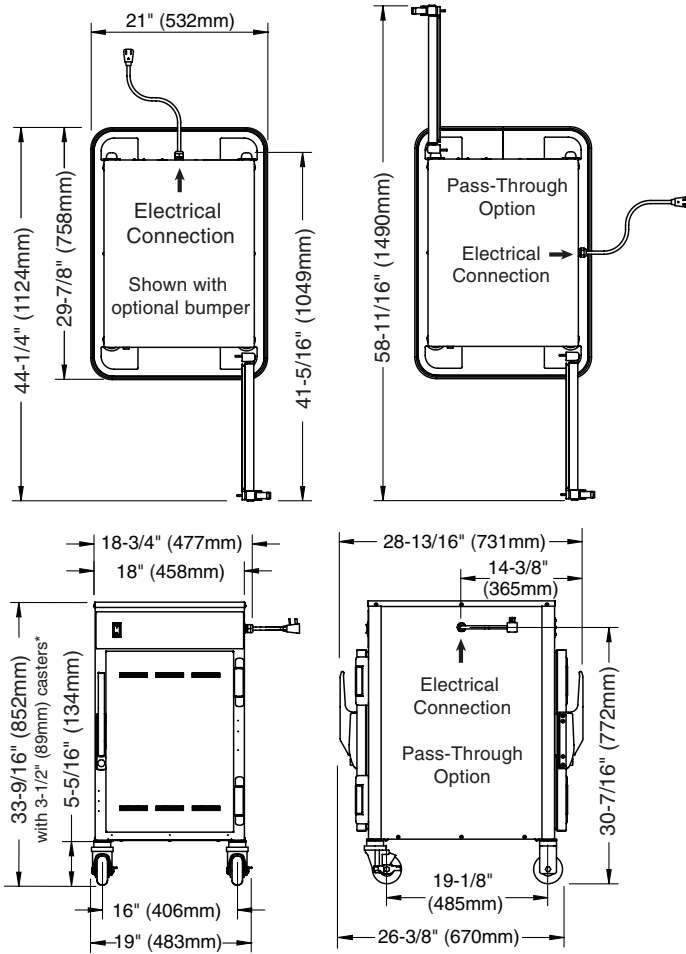

- *31-7/8" (809mm) - with optional 2-1/2" (64mm) casters
- *35-1/4" (895mm) - with optional 5" (127mm) casters
- *33-15/16" (861mm) - with optional 6" (152mm) legs

Model 750-S

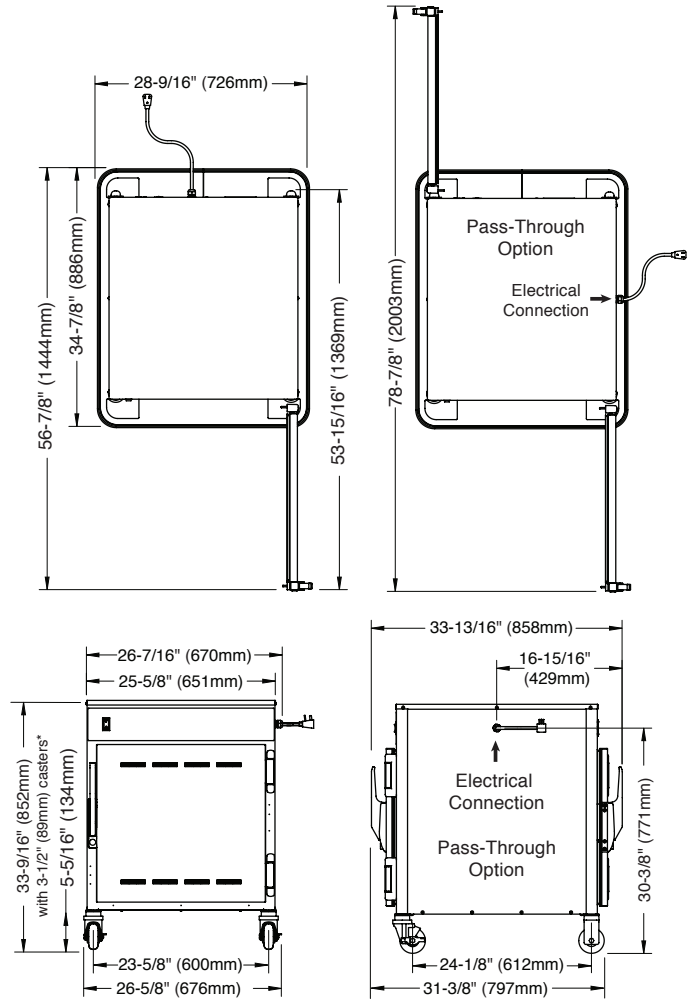

- *31-7/8" (809mm) - with optional 2-1/2" (64mm) casters
- *35-1/4" (895mm) - with optional 5" (127mm) casters
- *33-15/16" (861mm) - with optional 6" (152mm) legs

WEIGHTS AND CAPACITIES

WEIGHT - 500-S

NET	94 lb (43kg) EST.
SHIP	175 lb (79kg) EST.
CARTON DIMENSIONS: (L x W x H)	
35" x 35" x 41" (889mm x 889mm x 1041mm)	

WEIGHT - 750-S

NET	157 lb (69kg)
SHIP	228 lb (103kg) EST.
CARTON DIMENSIONS: (L x W x H)	
35" x 35" x 41" (889mm x 889mm x 1041mm)	

PRODUCT/PAN CAPACITY - 500-S

60 lbs (27 kg) MAXIMUM	
VOLUME MAXIMUM: 50 QUARTS (47.5 LITERS)	
FULL-SIZE PANS:	
Six (6)	20" x 12" x 2-1/2" 530mm x 325mm x 65mm
Three (3)	20" x 12" x 4" 530mm x 325mm x 100mm
HALF-SIZE SHEET PANS:	
Eleven (11)	18" x 13" x 1" 457mm x 330mm x 25mm

PRODUCT/PAN CAPACITY - 750-S

120 lbs (54 kg) MAXIMUM	
VOLUME MAXIMUM: 100 QUARTS (95 LITERS)	
FULL-SIZE PANS:	
Ten (10)	20" x 12" x 2-1/2" 530mm x 325mm x 65mm
Six (6)	20" x 12" x 4" 530mm x 325mm x 100mm
Four (4)	20" x 12" x 6" 530mm x 325mm x 150mm
FULL-SIZE SHEET PANS (ON WIRE SHELVES ONLY):	
Up to Six (6) 18" x 26" x 1" - WITH ADDITIONAL SHELVES	

INSTALLATION

Model 1000-S

Model 1200-S

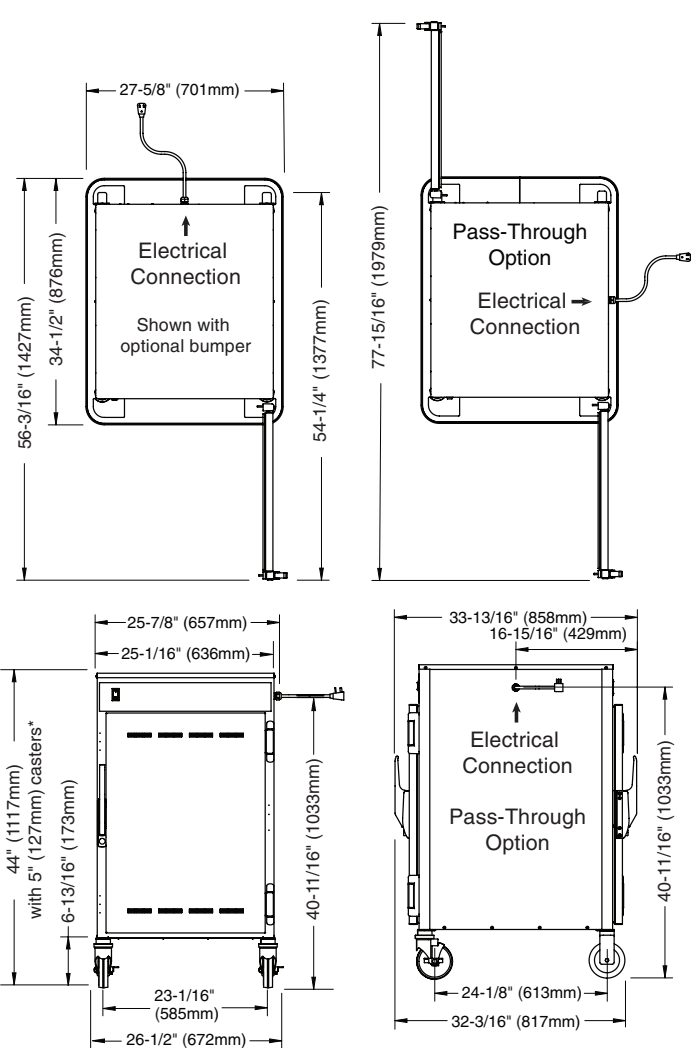
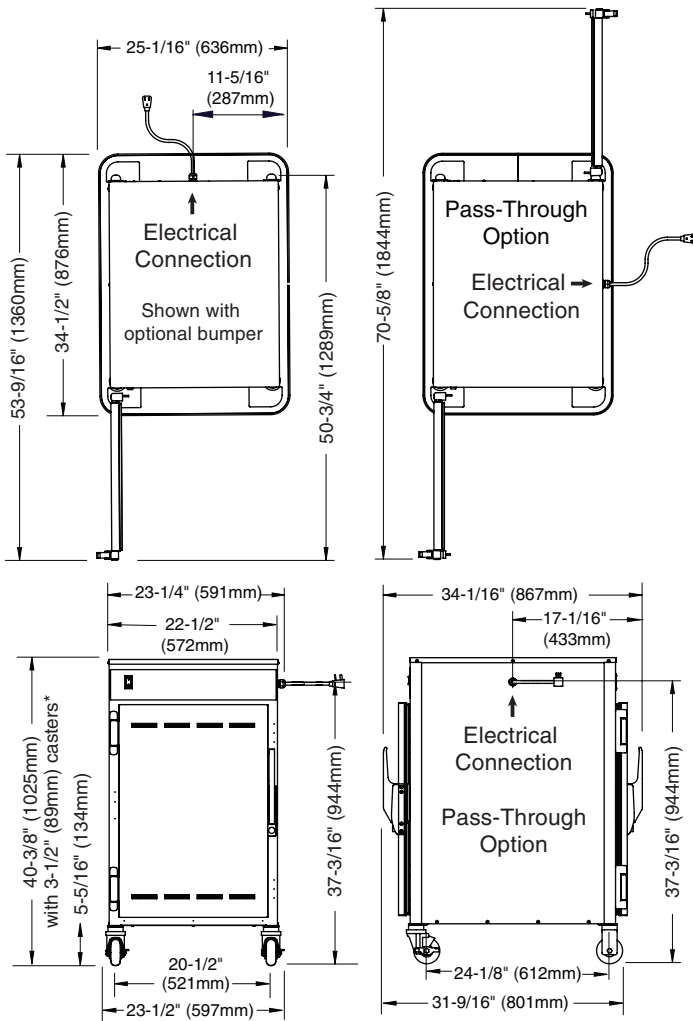

*38-11/16" (982mm) - with optional 2-1/2" (64mm) casters
 *42-1/16" (1068mm) - with optional 5" (127mm) casters
 *40-3/4" (1034mm) - with optional 6" (152mm) legs

*45-11/16" (1161mm) - with optional 3-1/2" (89mm) casters
 *43-7/8" (1113mm) - with optional 6" (152mm) legs

WEIGHTS AND CAPACITIES

WEIGHT - 1000-S

NET: 175 lb (79kg) EST. SHIP: 223 lb (101kg) EST.
 CARTON DIMENSIONS: (L x W x H)
 35" x 35" x 50" (889mm x 889mm x 1270mm)

WEIGHT - 1200-S

NET: 179 lb (81kg) EST. SHIP: 224 lb (102kg) EST.
 CARTON DIMENSIONS: (L x W x H)
 35" x 35" x 50" (889mm x 889mm x 1270mm)

PRODUCT/PAN CAPACITY - 1000-S

120 lbs (54kg) MAXIMUM
 VOLUME MAXIMUM: 60 QUARTS (76 LITERS)
FULL-SIZE PANS: **GASTRONORM 1/1:**
 Four (4) 20" x 12" x 2-1/2" 530mm x 325mm x 65mm
 — ON OPTIONAL WIRE SHELVES ONLY
FULL-SIZE SHEET PANS: Eight (8) 18" x 26" x 1"

PRODUCT/PAN CAPACITY - 1200-S

192 lbs (87kg) MAXIMUM
 VOLUME MAXIMUM: 120 QUARTS (152 LITERS)
 —WITH PAN SLIDES PROVIDED: —WITH ADDT'L PAN SLIDES:
FULL-SIZE PANS: **GASTRONORM 1/1:**
 Eight (8) 20" x 12" x 2-1/2" 530mm x 325mm x 65mm up to 16 Pans
 Eight (8) 20" x 12" x 4" 530mm x 325mm x 100mm up to 8 Pans
 Eight (8) 20" x 12" x 6" 530mm x 325mm x 150mm
FULL-SIZE SHEET PANS:
 Four (4) 18" x 26" x 1" up to 8 Pans
 UNIVERSAL PAN SLIDES - 1-3/4" (44mm) CENTERS with additional shelves
 —WITH OPTIONAL SIDE RACKS FOR SHELVES
FULL-SIZE PANS: **GASTRONORM 1/1:**
 Sixteen (16) 20" x 12" x 2-1/2" 530mm x 325mm x 65mm
 Eight (8) 20" x 12" x 4" 530mm x 325mm x 100mm
 Eight (8) 20" x 12" x 6" 530mm x 325mm x 150mm

INSTALLATION

Model 1000-UP

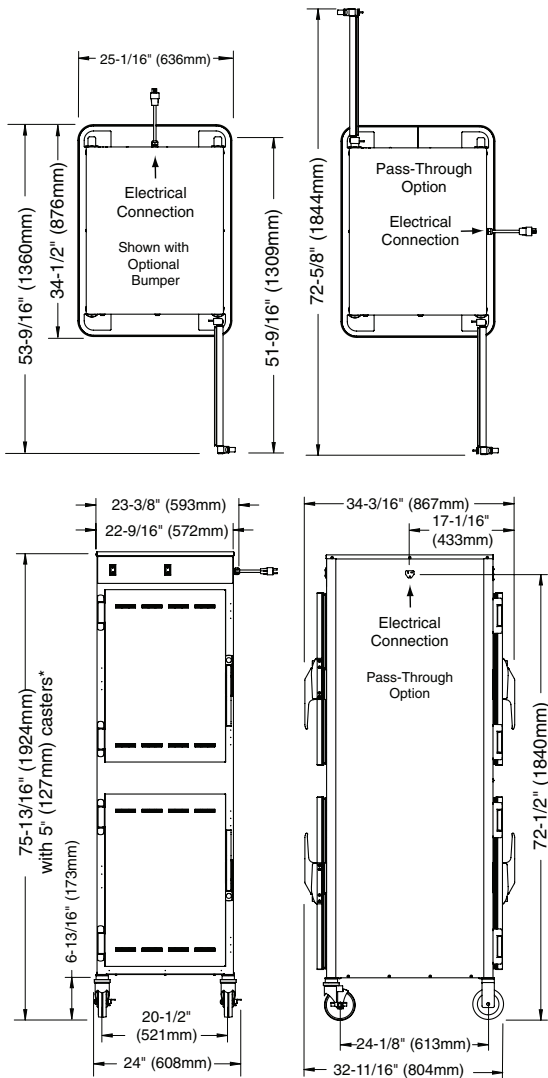

*74-1/16" (1881mm) - with optional 3-1/2" (89mm) casters
 *75-5/8" (1921mm) - with optional 6" (152mm) legs

Model 1200-UP

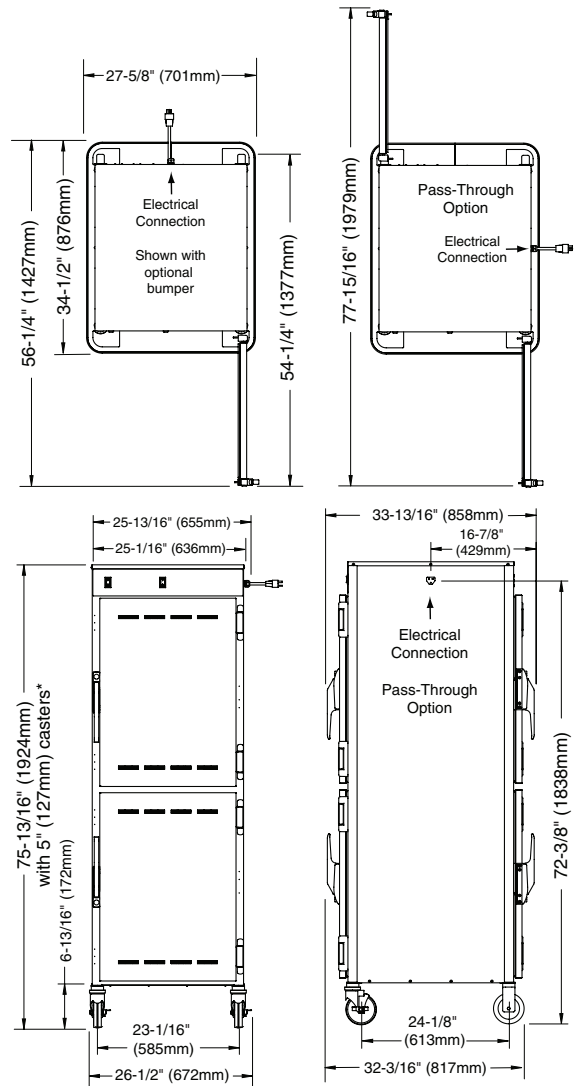

*74-1/16" (1881mm) - with optional 3-1/2" (89mm) casters
 *75-5/8" (1921mm) - with optional 6" (152mm) legs

WEIGHTS AND CAPACITIES

WEIGHT - 1000-UP

NET	282 lb (128kg)
SHIP	360 lb (163kg) EST.
CARTON DIMENSIONS: (L x W x H)	
35" x 35" x 82" (889mm x 889mm x 2083mm)	

WEIGHT - 1200-UP

NET	333 lb (151kg)
SHIP	393 lb (178kg) EST.
CARTON DIMENSIONS: (L x W x H)	
35" x 35" x 82" (889mm x 889mm x 2083mm)	

PRODUCT/PAN CAPACITY (PER COMPARTMENT)

192 lbs (87kg) MAXIMUM			
VOLUME MAXIMUM: 120 QUARTS (152 LITERS)			
—WITH PAN SLIDES PROVIDED:		—WITH ADDT'L PAN SLIDES:	
	FULL-SIZE PANS:	GASTRONORM 1/1:	
Eight (8)	20" x 12" x 2-1/2"	(530 x 325 x 65mm)	up to 16 Pans
Eight (8)	20" x 12" x 4"	(530 x 325 x 100mm)	up to 10 Pans
Eight (8)	20" x 12" x 6"	(530 x 325 x 150mm)	
	FULL-SIZE SHEET PANS:		
Four (4)	18" x 26" x 1"		up to 16 Pans
UNIVERSAL PAN SLIDES - 1-3/4" (44mm) CENTERS			
—WITH OPTIONAL SIDE RACKS FOR SHELVES			
	FULL-SIZE PANS:	GASTRONORM 1/1:	
Sixteen (16)	20" x 12" x 2-1/2"	(530 x 325 x 65mm)	
Ten (10)	20" x 12" x 4"	(530 x 325 x 100mm)	
Eight (8)	20" x 12" x 6"	(530 x 325 x 150mm)	

INSTALLATION

OPTIONS AND ACCESSORIES

MODEL >	500-S	750-S	1000-S	1200-S	1000-UP	1200-UP
DESCRIPTION	PART NO.	PART NO.	PART NO.	PART NO.	PART NO.	PART NO.
Bumper, Full Perimeter	5011161	5010371	5009767	5012932	5009767	5012932
Carving Holder, Prime Rib	HL-2635	HL-2635	--	--	--	--
Carving Holder, Steamship (Cafeteria) Round	4459	4459	--	--	--	--
Caster Package, 2-1/2" (64mm)	5008022	5008022	5008022	--	--	--
Caster Package, 3-1/2" (89mm)	STANDARD	STANDARD	STANDARD	5008017	5008017	5008017
Caster Package, 5" (127mm)	5004862	5004862	5004862	STANDARD	STANDARD	STANDARD
Door Assembly, Window	--	5013129	5012806	5012822	5012806	5012822
Door Lock with Key	LK-22567	LK-22567	LK-22567	LK-22567	LK-22567	LK-22567
Drip Pan, with Drain 1-7/16" (48mm)	14813	--	--	--	--	--
Drip Pan, with Drain 1-11/16" (43mm)	--	14831	--	--	--	--
Drip Pan, with Drain 1- 7/8" (48mm)	--	--	5005616	--	5005616	--
Drip Pan, without Drain 1-7/16" (48mm)	11898	--	--	--	--	--
Drip Pan, without Drain 1-7/8" (48mm)	--	--	11906	--	11906	--
Drip Tray, Door	5010736	5010391	5009716	--	--	--
Deluxe Control (FACTORY INSTALLED)	AVAILABLE	AVAILABLE	AVAILABLE	AVAILABLE	AVAILABLE	AVAILABLE
Handle Kit, Push/Pull (SET OF FOUR)	55662	55662	55662	55662	55662	55662
Legs, 6" (152mm)	5011149	5011149	5011149	5011149	5011149	5011149
Pan Grid, Wire 18" x 26" (457mm x 660mm)	--	PN-2115	PN-2115	PN-2115	PN-2115	PN-2115
Probe, Internal Product Temp. (DELUXE ONLY)	AVAILABLE	AVAILABLE	AVAILABLE	AVAILABLE	AVAILABLE	AVAILABLE
Security Panel with Key Lock	5006787	5004750	5005776	--	--	--
Shelf, Chrome Wire	SH-2107	SH-2105	--	SH-2733	--	SH-2733
Shelf, Chrome Wire, Pass-Through	--	SH-2327	--	--	--	--
Shelf, Stainless Steel Wire	SH-2326	SH-2324	SH-2325	SH-23738	SH-2325	SH-23738
Shelf, Stainless Steel, Rib Rack	--	SH-2743	--	--	--	--
Shelf, Stainless Steel, Pass-Through	--	--	SH-2346	SH-23738	SH-2346	--
Side Rack Kit (FACTORY INSTALLED)	--	--	--	AVAILABLE	--	AVAILABLE
Stacking Hardware	5004864	5004864	5004864	5004864	--	--
Universal Angle Pan Slides, Chrome	--	--	--	SR-24447	--	SR-24447
Universal Angle Pan Slides, Stainless Steel	--	--	--	SR-24762	--	SR-24762
Water Reservoir, Pan	--	--	1775	1775	1775	1775
Water Reservoir, Pan Cover	--	--	1774	1774	1774	1774

CAUTION

Pass-through models with same side door hinging must be installed with flanged feet bolted to the floor to avoid tipping hazards.

INSTALLATION

OPTIONS AND ACCESSORIES

UNIVERSAL PAN SLIDES

As an alternative to universal pan slides, the 1200-UP model can be ordered as a "side rack" model which is equipped with two (2) side racks and three (3) chrome plated wire shelves per compartment.

Universal Pan Slides,
SR-24762, stainless steel
SR-24447, chrome plate

Side Rail
1011741

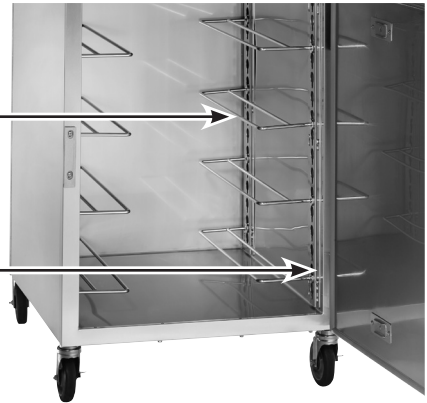

SIDE RACKS AND SHELVES

Model 1200-UP that has been converted with side racks to accommodate full and half size U.S. Hotel and European Gastronorm pans or sheet pans on the side racks.

Shelf
SH-23738, stainless steel
SH-2733, chrome plate

Side Rack
1011743



INSTALLATION

SITE INSTALLATION

A number of adjustments are associated with initial installation and start-up. It is important that these adjustments be conducted by a qualified service technician. Installation and start-up adjustments are the responsibility of the dealer or user. These adjustments include but are not limited to thermostat calibration, door adjustment, leveling, electrical hook-up and installation of optional casters or legs.

LEVELING

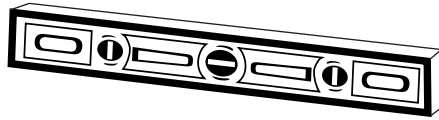

Level the oven from side-to-side and front-to-back with the use of a spirit level. For ovens installed with casters, it is important that the installation surface be level due to the probability of frequent oven repositioning.

We recommend checking the level of the oven periodically to make certain the floor has not shifted nor the oven moved.

NOTE: Failure to properly level this oven may result spills from a semi-liquid product.

RESTRAINT REQUIREMENTS —MOBILE EQUIPMENT

 WARNING	
	RISK OF ELECTRIC SHOCK. Appliance must be secured to building structure.

Any appliance that is not furnished with a power supply cord but that includes a set of casters must be installed with a tether. Adequate means must be provided to limit the movement of this appliance without depending on or transmitting stress to the electrical conduit. The following requirements apply:

1. Maximum height of casters is 6" (152mm).
2. Two of the casters must of be the locking type.
3. Such mobile appliances or appliances on mobile stands must be installed with the use of a flexible connector secured to the building structure.

A mounting connector for a restraining device is located on the upper back flange of the appliance. A flexible connector is not supplied by nor is it available from the factory.

INSTALLATION

SITE INSTALLATION

DRIP TRAY INSTALLATION INSTRUCTIONS

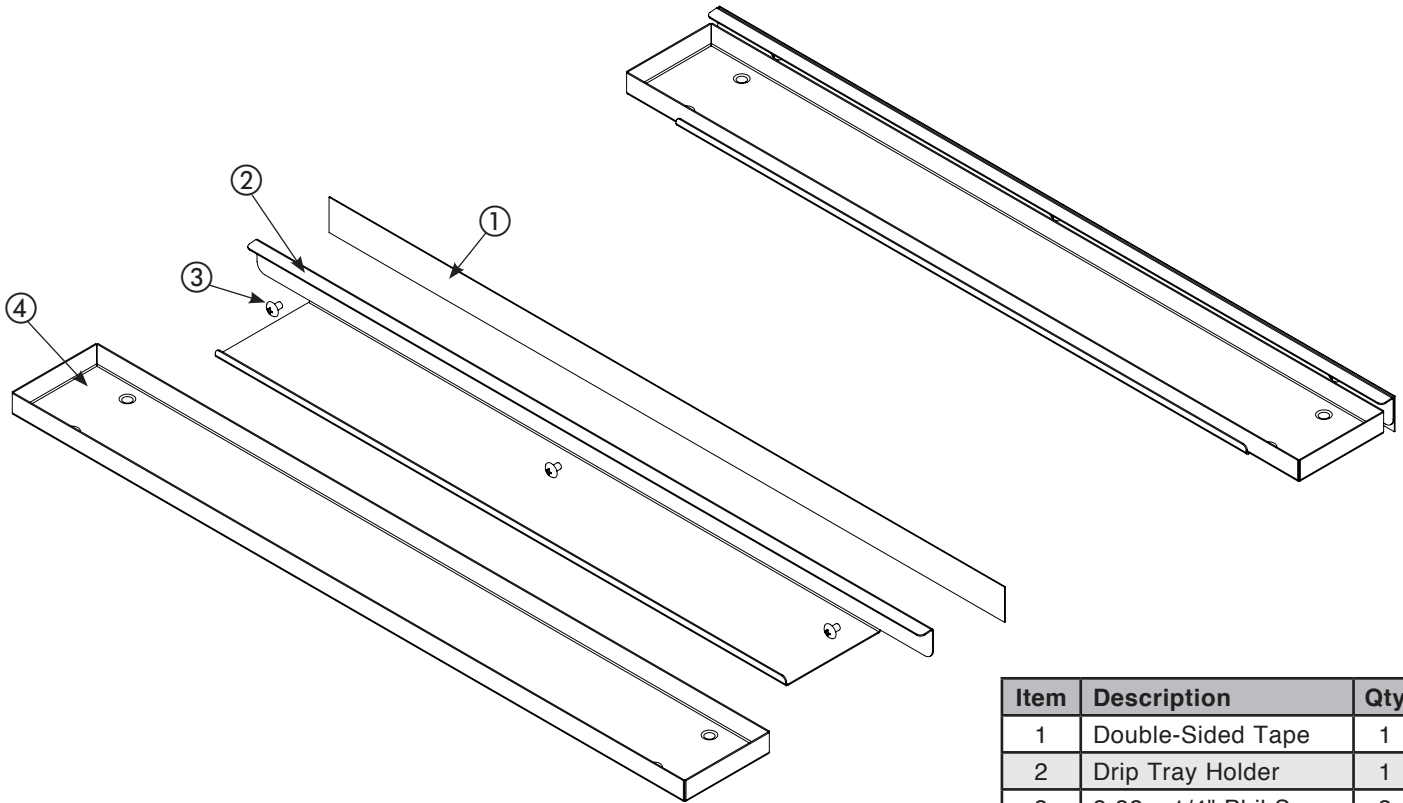

Item	Description	Qty
1	Double-Sided Tape	1
2	Drip Tray Holder	1
3	8-32 x 1/4" Phil Screw	3
4	Drip Tray	1

1. Poke holes through double-sided tape ① which is attached to the back of drip tray holder ②.
2. Remove backing on double-sided tape ①.
3. Put screws ③ through holes and attach drip tray holder ② to unit.
4. Optional - apply a line of food-grade silicone caulk along top edge of drip tray holder ② to seal.
5. Place drip tray ④ in drip tray holder ②.

DANGER

**ENSURE POWER SOURCE
MATCHES VOLTAGE STAMPED
ON APPLIANCE NAMEPLATE.**

INSTALLATION

ELECTRICAL

1. An identification tag is permanently mounted on the cabinet.
2. Plug cabinet into a properly grounded receptacle ONLY, positioning the unit so the power supply cord is easily accessible in case of an emergency.
Arcing will occur when connecting or disconnecting the unit unless all controls are in the "OFF" position.
3. If necessary, a proper receptacle or outlet configuration as required for this unit, must be installed by a licensed electrician in accordance with applicable, local electrical codes.

For CE approved units:

To prevent an electrical shock hazard between the appliance and other appliances or metal parts in close vicinity, an equalization-bonding stud is provided. An equalization bonding lead must be connected to this stud and the other appliances / metal parts to provide sufficient protection against potential difference. The terminal is marked with the following symbol. 

NOTE: CE approved appliance must be connected to an electrical circuit that is protected by an external GFCI outlet.

Hard wired models:

Hard wired models must be equipped with a country certified external allpole disconnection switch with sufficient contact separation.

If a power cord is used for the connection of the product an oil resistant cord like H05RN or H07RN or equivalent must be used.

CAUTION

THIS SECTION IS PROVIDED FOR THE ASSISTANCE OF QUALIFIED SERVICE TECHNICIANS ONLY AND IS NOT INTENDED FOR USE BY UNTRAINED OR UNAUTHORIZED SERVICE PERSONNEL.



DANGER



ENSURE POWER SOURCE MATCHES VOLTAGE STAMPED ON APPLIANCE NAMEPLATE.







DANGER















To avoid electrical shock, this appliance **MUST** be adequately grounded in accordance with local electrical codes or, in the absence of local codes, with the current edition of the National Electrical Code ANSI/NFPA No. 70. In Canada, all electrical connections are to be made in accordance with CSA C22.1, Canadian Electrical Code Part 1 or local codes.

INSTALLATION

ELECTRICAL

500-S							750-S						
VOLTAGE	PHASE	CYCLE/HZ	AMPS	kW	CORD & PLUG		VOLTAGE	PHASE	CYCLE/HZ	AMPS	kW	CORD & PLUG	
120 (AGCY)	1	60	8.0	.96	NEMA 5-15P, 		120 (AGCY)	1	60	8.0	.96	NEMA 5-15P, 	
120	1	60	8.0	.96	15A-125V PLUG		120	1	60	8.0	.96	15A-125V PLUG	
208-240 (AGCY)	1	60	4.0	.96	NEMA 6-15P, 		208-240 (AGCY)	1	60	4.0	.96	NEMA 6-15P, 	
at 208	1	60	3.5	.72	15A-250V PLUG		at 208	1	60	3.5	.72	15A-250V PLUG	
at 240	1	60	4.0	.96	(USA ONLY)		at 240	1	60	4.0	.96	(USA ONLY)	
230 (AGCY)	1	50	4.1	.95	CEE 7/7, 		230 (AGCY)	1	50	4.3	1.0	CEE 7/7, 	
230	1	50	4.0	.93	220-230V PLUG		230	1	50	4.3	.99	220-230V PLUG	

1000-S							1000-UP						
VOLTAGE	PHASE	CYCLE/HZ	AMPS	kW	CORD & PLUG		VOLTAGE	PHASE	CYCLE/HZ	AMPS	kW	CORD & PLUG	
120 (AGCY)	1	60	8.0	.96	NEMA 5-15P, 		120 (AGCY)	1	60	16.0	1.9	NEMA 5-20P, 	
120	1	60	8.0	.96	15A-125V PLUG							20A-125V PLUG	
208-240 (AGCY)	1	60	4.0	.96	NEMA 6-15P, 		208-240 (AGCY)	1	60	8.0	1.9	NEMA 6-15P, 	
at 208	1	60	3.5	.72	15A-250V PLUG		at 208	1	60	7.0	1.4	15A-250V PLUG	
at 240	1	60	4.0	.96	(USA ONLY)		at 240	1	60	8.0	1.9	(USA ONLY)	
230 (AGCY)	1	50	3.8	.88	CEE 7/7, 		230 (AGCY)	1	50	7.7	1.8	CEE 7/7, 	
230	1	50	3.8	.88	220-230V PLUG		230	1	50	7.7	1.8	220-230V PLUG	

1200-S							1200-UP								
VOLTAGE	PHASE	CYCLE/HZ	AMPS	kW	CORD & PLUG		VOLTAGE	PHASE	CYCLE/HZ	AMPS	kW	CORD & PLUG			
120	at 120	1	60	8.0	.96	NEMA 5-15P, 		120	at 120	1	60	16.0	1.9	NEMA 5-20P, 	
						15A-125V PLUG								20A-125V PLUG	
208 - 240 2000W	208-240 (AGCY)	1	60	4.0	.96	NEMA 6-15P, 		208-240 (AGCY)	1	60	8.0	1.9	NEMA 6-15P, 		
	at 208	1	60	3.5	.72	15A-250V PLUG		at 208	1	60	7.0	1.4	15A-250V PLUG		
	at 240	1	60	4.0	.96	(USA ONLY)		at 240	1	60	8.0	1.9	(USA ONLY)		
2000W	208-240 (AGCY)	1	60	8.0	1.9	NO CORD		208-240 (AGCY)	1	60	16.0	3.8	NO CORD		
	at 208	1	60	6.9	1.4	NO PLUG		at 208	1	60	14.0	2.9	NO PLUG		
	at 240	1	60	8.0	1.9			at 240	1	60	16.0	3.8			
230	at 230 1000W	1	50	3.8	.88	CEE 7/7, 		230	at 230 2000W	1	50	7.7	1.9	CEE 7/7, 	
	at 230 2000W	1	50	7.7	1.8	220-230V PLUG		at 230 4000W	1	50	15.4	3.5	220-230V PLUG		

Wire diagrams located inside the top of the unit.

CAUTION

THIS SECTION IS PROVIDED FOR THE ASSISTANCE OF QUALIFIED SERVICE TECHNICIANS ONLY AND IS NOT INTENDED FOR USE BY UNTRAINED OR UNAUTHORIZED SERVICE PERSONNEL.



DANGER



ENSURE POWER SOURCE MATCHES VOLTAGE STAMPED ON APPLIANCE NAMEPLATE.

INSTALLATION

USER INFORMATION

USER SAFETY INFORMATION

This appliance is intended for use in commercial establishments where all operators are familiar with the purpose, limitations, and associated hazards of this appliance. Operating instructions and warnings must be read and understood by all operators and users.

1. Unit must be connected to the appropriate power source.
2. Use hand protection when handling hot items.
3. Preheat the unit for 30 minutes before use.
4. Be certain only hot foods are placed into the unit.

CAUTION	
	METAL PARTS OF THIS EQUIPMENT BECOME EXTREMELY HOT WHEN IN OPERATION. TO AVOID BURNS, ALWAYS USE HAND PROTECTION WHEN OPERATING THIS APPLIANCE.

BEFORE INITIAL USE:

1. Clean both the interior and exterior of the unit with a damp, clean cloth and mild soap solution. Rinse carefully.
2. Clean and install the cabinet side racks. Shelves should be positioned with the curved end up and toward the back of the unit (reach-in models).

HEATING CHARACTERISTICS

The cabinet is equipped with a special heating cable. Through this Halo Heat concept, the heating cable is mounted against the walls of the unit to provide an evenly applied heat source controlled by a thermostat. The design and operational characteristics of the unit eliminate the need for a moisture pan or a heat circulating fan. Through even heat application, the quality of food products is maintained up to several hours or more.

OPERATION

OPERATING INSTRUCTIONS

1. PREHEAT AT 200°F (93°C) FOR 30 MINUTES BEFORE LOADING FOOD.

Push power switch to "ON" position. The unit will begin operating at the previous set temperature.

2. Press the **Up or Down Arrow Keys** to 200°F (93°C). Pressing and releasing the Arrow Keys will increase the set point by 1 degree. Pressing and holding the Arrow Key will increase set point by 10 degrees. When Arrow Key is released, a new set point temperature is set. The **Set** temperature will appear in the **Digital Display** and the **Heat Indicator Light** will illuminate. Press the **Temperature Display Key** for three seconds at any time to display the **Actual** inside air temperature.

To toggle between Set and Actual:

Factory default is to display **Set** temperature in the **Digital Display**. To display **Actual** temperature:

Press and hold the **Temperature Display Key** and the **Up Arrow Key** for 5 seconds. The control will show **ACT**, then show the **Actual** temperature.

Repeat to toggle to **Set** point **SET**.

Press the **Temperature Display Key** at any time to display the alternate temperature.

3. When the inside air temperature reaches the desired holding temperature, the **Heat Indicator Light** will turn off.
4. **Load the cabinet with hot food only.** The purpose of the holding cabinet is to maintain hot food at proper serving temperatures. Only hot food should be placed into the cabinet. Before loading the unit with food, use a food thermometer to make certain all food products are at an internal temperature range of 140° to 160°F (60° to 71°C). All food not within the proper temperature range should be heated before loading into the holding cabinet.

5. Check to make certain the cabinet door is securely closed, and using the **Up and Down Arrow Keys**, set the temperature to 160°F (71°C).

THIS WILL NOT NECESSARILY BE THE FINAL SETTING.

The proper temperature range for the food being held will depend on the type and quantity of product. Whether or not the door vents should be open or closed will also depend on the type of food being held. When holding food for prolonged periods, it is advisable to periodically check the internal temperature of each item to assure maintenance of the proper temperature range. Reset the holding temperature accordingly.

TO TOGGLE BETWEEN FAHRENHEIT AND CELSIUS

Press the **Temperature Display Key** at any time to display the alternate temperature.

The factory default is Fahrenheit. To change to Celsius:

1. Press and hold the **Temperature Display Key** and the **Down Arrow Key** for 5 seconds.
2. The control will show **°C** for 3 seconds to verify selection and then show the temperature. (Set Point or Actual, whichever the user has selected) in °C.
3. Repeat to toggle to Fahrenheit.

Note: With a power failure, factory test, etc., the control will retain the °C or °F setting selected by the user when power is restored.

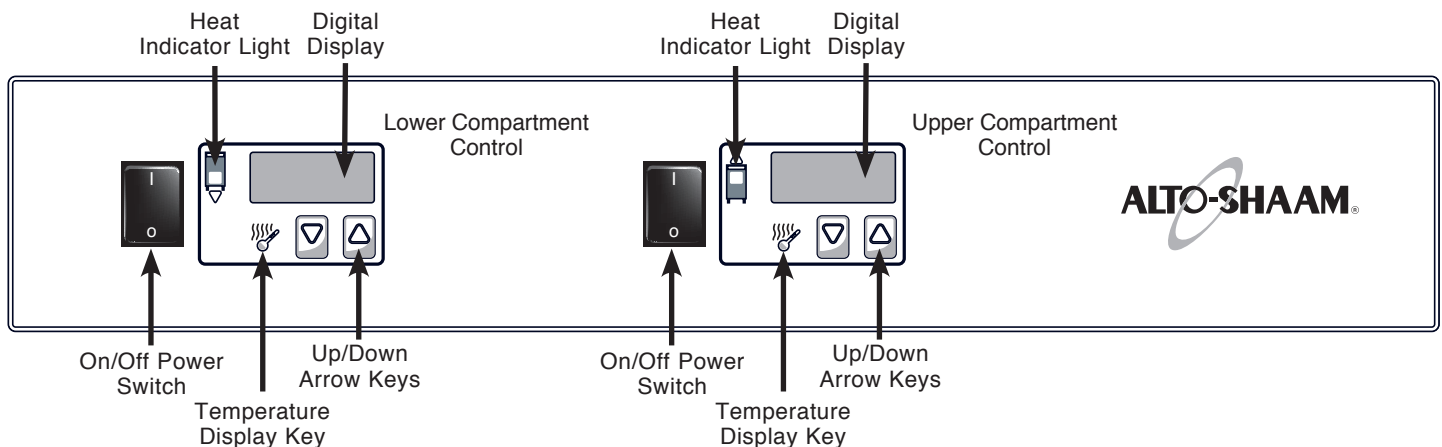

OPERATION

DELUXE CONTROL OPTION

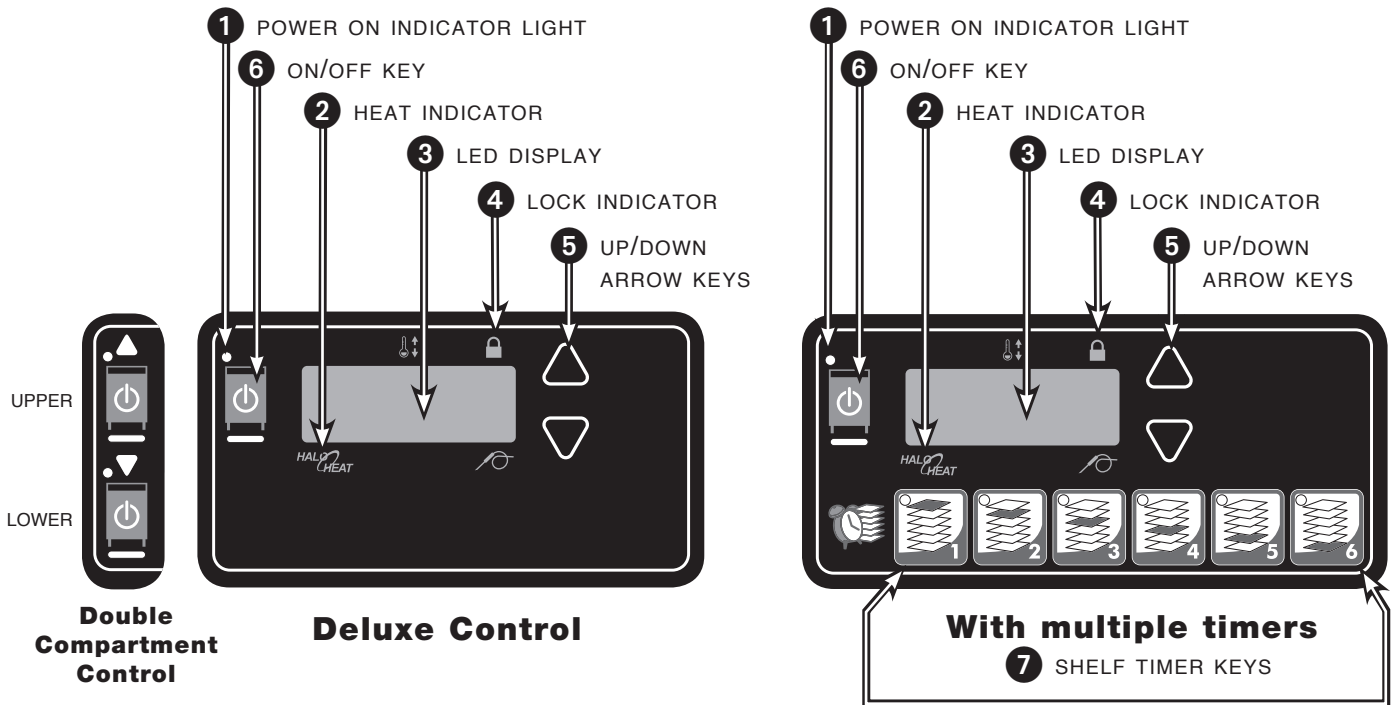

DELUXE CONTROL SET-UP

ON/OFF KEY



Press the ON/OFF key once and the power indicator light will illuminate. Press and hold the ON/OFF key until the LED display turns off (at least three seconds) and power indicator light goes out.

UP/DOWN ARROW KEY



The UP and DOWN arrow keys are used for a variety of settings when selecting the holding temperature. If an arrow key is pressed and released the display will show the current set temperature for four seconds. If an arrow key is held (at least eight seconds), the value will change at a rapid rate. Pressing an arrow key when the set temperature is displayed will increase/decrease the temperature by 1°. Pressing and holding an arrow will increase/decrease the temperature by 10°.

ENABLE / DISABLE BEEPER



A beeper sounds when an error code is displayed. To choose between beeper on and beeper off mode, the control must be off, then press and hold the DOWN arrow key until either "ON" or "OFF" is shown in the LED display. Press either arrow button to toggle the beeper mode.

FAHRENHEIT/CELSIUS

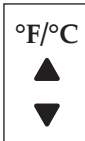

With the control off, to choose between Fahrenheit and Celsius, press and hold the UP arrow key until either °F or °C is shown in LED display. Press either arrow key to toggle the temperature scale.

The control has a four-digit LED display. When the display is on, it will show current holding temperature, as well as diagnostic information.

CONTROL LOCK

The warmer controls can be locked so that no changes can be made to the set temperature.



To lock the display, press and hold the ON/OFF key and the Up Arrow key at the same time. The lock LED will illuminate. When the lock LED is illuminated, additional programming will not be functional other than the key sequence required to unlock the panel. To unlock the display, press and hold the ON/OFF key and the Down Arrow key at the same time. The lock LED will extinguish. The panel keys will resume normal function.

OPERATION

DELUXE CONTROL OPERATION

1. Preheat at 200°F (93°C) for 30 minutes.

Press the ON key, and set the temperature to 200°F (93°) by using the UP/DOWN arrow keys. Allow a minimum of 30 minutes preheating time before loading the holding cabinet with food. Closing the vents on the inside of the door will speed the preheating process. The LED heat indicator light will go “Out” after approximately 30 minutes preheat time, or when the air temperature inside the unit reaches the temperature set by the operator. The Set indicator will light up anytime the temperature is set or reset.

2. Load with hot food only.

The purpose of the holding cabinet is to maintain hot food at proper serving temperature. Only hot food should be placed into the cabinet. Before loading the cabinet with food, use a food thermometer to make certain all products are at an internal temperature range of 140° to 160°F (60° to 71°C). Any food product not within the proper temperature range should be heated before loading into the holding cabinet.

3. Reset the control to 160°F (71°C).

Check to make certain the cabinet door is securely closed, and reset to 160°F (71°C) by using the UP/DOWN keys

**THIS WILL NOT NECESSARILY
BE THE FINAL SETTING.**

The proper temperature range and OPEN or CLOSED door vent position will depend on the type and quantity of product. When holding food for prolonged periods, it is advisable to periodically check the internal temperature of each item with a food thermometer to assure maintenance of the proper temperature range of 140° to 160°F (60° to 71°C).

SureTemp™ Heat Recovery

The patented SureTemp™ heat recovery system in this unit will immediately compensate for any loss of heat when the door is opened. In order to maintain a more consistent cavity temperature, the control will automatically apply heat to the unit’s interior while the door is open and for a short time after the door is closed. If the door remains open for more than three minutes, the control will sound three rapid beeps every ten seconds until the door is closed.

DOUGH PROOFING INSTRUCTIONS

SIMPLE AND DELUXE CABINETS

With the addition of a pan of water, warming cabinets can be used for proofing dough. A water reservoir pan (#1775) and pan cover (#1774) is available as an option from Alto-Shaam.

1. Remove dough from retarder or refrigerator and allow covered product to set up at room temperature.
2. Set holding thermostat temperature to 95°F (35°C).
3. Pour approximately 2 quarts (c. 2 liters) of hot water into the optional water reservoir pan and place the pan on the bottom surface of the compartment. The temperature of the water should be 140° to 180°F (60° to 82°C).
4. Allow the cabinet to preheat for 45 to 60 minutes.
5. Remove covering and place dough in preheated cabinet.
6. Allow dough to remain in the cabinet until it nearly doubles in size.
7. Remove product from cabinet and bake according to product manufacturer’s directions. Brush with eggwash if desired.

NOTE: The above proofing procedure is a suggested guideline only. Due to variation from product to product, including quality and product weight, close adherence the product manufacturer’s instructions is strongly recommended.

OPERATION

DELUXE CONTROL TIMER PROGRAMMING

Timer Programming Information

1. Turn On/Off Control Key OFF.



Press the On/Off Key until the display turns OFF (at least 3 seconds) and On/Off Key's Power Indicator Light goes out.

Note: The following steps can only be done when the Control is OFF.

2. Set Shelf Timer Keys.



Press and hold a Shelf Timer Key (at least 3 seconds) until the countdown time is shown in the LED display. Use the Up or Down Arrow Key to change the time desired.

Time will display as HH:MM.

3. Set Additional Timer Keys.



Repeat step 2 for each Shelf Timer Key to be programmed.

4. Turn On/Off Power Key ON.



Using the timer, press the On/Off key to turn ON unit. Power Indicator Light will illuminate.

The Multiple Shelf Timer Key option is available for hot food holding units with the Deluxe Control. These keys monitor food safety by using a timer-based "First-In, First-Out" product management system. Products should be cooked to HACCP recommended internal temperature and then held in the unit. The Timer system allows operator to select holding times when the unit is loaded. Multiple timer keys correspond to various pan locations in the holding unit. As the timers expire, the LED will flash quickly in order to notify the operator.

5. Press Shelf Timer Key.



Activate the shelf timer by pressing the corresponding button. Shelf LED display will illuminate and the count down will begin. The timer will display as HH:MM when the remaining time is >60 minutes. It will display as MM:SS when the remaining time is <60 minutes.

The timer LED's will illuminate as follows:

- All expired timers will flash quickly (may be more than one)
- The timer with the shortest amount of time remaining will flash slowly.
- All other active timers will be illuminated (may be more than one).

6. Acknowledge expired timers.

The LED will quickly flash when time expires. Press expired Shelf Timer Key to acknowledge expired timer.

To Cancel a Timer:

Press and hold desired Shelf Timer Key for two seconds.

Power Failure:

The Power Indicator Light by On/Off Power Key will blink to indicate a power failure. To stop the blinking, simply depress On/Off Key. The memory will not be impaired.

OPERATION

GENERAL HOLDING GUIDELINES

Chefs, cooks and other specialized food service personnel employ varied methods of cooking. Proper holding temperatures for a specific food product must be based on the moisture content of the product, product density, volume, and proper serving temperatures. Safe holding temperatures must also be correlated with palatability in determining the length of holding time for a specific product.

Halo Heat maintains the maximum amount of product moisture content without the addition of water, water vapor, or steam. Maintaining maximum natural product moisture preserves the natural flavor of the product and provides a more genuine taste. In addition to product moisture retention, the gentle properties of Halo Heat maintain a consistent temperature throughout the cabinet without the necessity of a heat distribution fan, thereby preventing further moisture loss due to evaporation or dehydration.

In an enclosed holding environment, too much moisture content is a condition which can be relieved. A product achieving extremely high temperatures in preparation must be allowed to decrease in temperature before being placed in a controlled holding atmosphere. If the product is not allowed to decrease in temperature, excessive condensation will form increasing the moisture content on the outside of the product. To preserve the safety and quality of freshly cooked foods however, a maximum of 1 to 2 minutes must be the only time period allowed for the initial heat to be released from the product.

Most Halo Heat holding equipment is provided with a thermostat control between 60° and 200°F (16° to 93°C). If the unit is equipped with vents, close the vents for moist holding and open the vents for crisp holding.

HOLDING TEMPERATURE RANGE		
MEAT	FAHRENHEIT	CELSIUS
BEEF ROAST — Rare	130°F	54°C
BEEF ROAST — Med/Well Done	155°F	68°C
BEEF BRISKET	160° — 175°F	71° — 79°C
CORN BEEF	160° — 175°F	71° — 79°C
PASTRAMI	160° — 175°F	71° — 79°C
PRIME RIB — Rare	130°F	54°C
STEAKS — Broiled/Fried	140° — 160°F	60° — 71°C
RIBS — Beef or Pork	160°F	71°C
VEAL	160° — 175°F	71° — 79°C
HAM	160° — 175°F	71° — 79°C
PORK	160° — 175°F	71° — 79°C
LAMB	160° — 175°F	71° — 79°C
POULTRY		
CHICKEN — Fried/Baked	160° — 175°F	71° — 79°C
DUCK	160° — 175°F	71° — 79°C
TURKEY	160° — 175°F	71° — 79°C
GENERAL	160° — 175°F	71° — 79°C
FISH/SEAFOOD		
FISH — Baked/Fried	160° — 175°F	71° — 79°C
LOBSTER	160° — 175°F	71° — 79°C
SHRIMP — Fried	160° — 175°F	71° — 79°C
BAKED GOODS		
BREADS/ROLLS	120° — 140°F	49° — 60°C
MISCELLANEOUS		
CASSEROLES	160° — 175°F	71° — 79°C
DOUGH — Proofing	80° — 100°F	27° — 38°C
EGGS — Fried	150° — 160°F	66° — 71°C
FROZEN ENTREES	160° — 175°F	71° — 79°C
HORS D'OEUVRES	160° — 180°F	71° — 82°C
PASTA	160° — 180°F	71° — 82°C
PIZZA	160° — 180°F	71° — 82°C
POTATOES	180°F	82°C
PLATED MEALS	140° — 165°F	60° — 74°C
SAUCES	140° — 200°F	60° — 93°C
SOUP	140° — 200°F	60° — 93°C
VEGETABLES	160° — 175°F	71° — 79°C
THE HOLDING TEMPERATURES LISTED ARE SUGGESTED GUIDELINES ONLY. ALL FOOD HOLDING SHOULD BE BASED ON INTERNAL PRODUCT TEMPERATURES. ALWAYS FOLLOW LOCAL HEALTH (HYGIENE) REGULATIONS FOR ALL INTERNAL TEMPERATURE REQUIREMENTS.		

CARE AND CLEANING

CLEANING AND PREVENTIVE MAINTENANCE

PROTECTING STAINLESS STEEL SURFACES



It is important to guard against corrosion in the care of stainless steel surfaces. Harsh, corrosive, or inappropriate chemicals can completely destroy the protective surface layer of stainless steel. Abrasive

pads, steel wool, or metal implements will abrade surfaces causing damage to this protective coating and will eventually result in areas of corrosion. Even water, particularly hard water that contains high to moderate concentrations of chloride, will cause oxidation and pitting that result in rust and corrosion. In addition, many acidic foods spilled and left to remain on metal surfaces are contributing factors that will corrode surfaces.





Proper cleaning agents, materials, and methods are vital to maintaining the appearance and life of this appliance. Spilled foods should be removed and the area wiped as soon as possible but at the very least, a minimum of once a day. Always thoroughly rinse surfaces after using a cleaning agent and wipe standing water as quickly as possible after rinsing.

CLEANING AGENTS

Use non-abrasive cleaning products designed for use on stainless steel surfaces. Cleaning agents must be chloride-free compounds and must not contain quaternary salts. Never use hydrochloric acid (muriatic acid) on stainless steel surfaces. Always use the proper cleaning agent at the manufacturer's recommended strength. Contact your local cleaning supplier for product recommendations.

CLEANING MATERIALS

The cleaning function can usually be accomplished with the proper cleaning agent and a soft, clean cloth. When more aggressive methods must be employed, use a non-abrasive scouring pad on difficult areas and make certain to scrub with the visible grain of surface metal to avoid surface scratches. Never use wire brushes, metal scouring pads, or scrapers to remove food residue.

 CAUTION	
	TO PROTECT STAINLESS STEEL SURFACES, COMPLETELY AVOID THE USE OF ABRASIVE CLEANING COMPOUNDS, CHLORIDE BASED CLEANERS, OR CLEANERS CONTAINING QUATERNARY SALTS. NEVER USE HYDROCHLORIC ACID (MURIATIC ACID) ON STAINLESS STEEL. NEVER USE WIRE BRUSHES, METAL SCOURING PADS OR SCRAPERS.
	
	

CARE AND CLEANING



The cleanliness and appearance of this equipment will contribute considerably to operating efficiency and savory, appetizing food. Good equipment that is kept clean works better and lasts longer.

CLEAN THE HOLDING CABINET DAILY:

1. Disconnect unit from power source, and let cool.
2. Remove all detachable items such as shelves, side racks, and drip pan. Clean these items separately with a good grease solvent or commercial detergent. Rinse well and dry.
3. Clean interior metal surfaces of the unit with a damp, clean cloth and any good commercial detergent or grease solvent at the recommended strength. Spray heavily soiled areas with a water soluble degreaser and let stand for 10 minutes, then remove soil with a plastic scouring pad. Rinse by wiping with a sponge and clean warm water to remove all residue. Remove excess water with sponge and wipe dry with a clean cloth or air dry. Replace side racks and shelves.
4. Clean control panel, door vents, door handles, and door gaskets thoroughly since these areas harbor food debris. Rinse by wiping with sponge and clean warm water. Wipe dry with a clean cloth.
5. Interior can be wiped with a sanitizing solution after cleaning and rinsing. This solution must be approved for use on stainless steel food contact surfaces.
6. To help maintain the protective film coating on polished stainless steel, clean the exterior of the unit with a cleaner recommended for stainless steel surfaces. Spray the cleaning agent on a clean cloth and wipe with the grain of the stainless steel.



NOTE: Avoid the use of abrasive cleaning, compounds, chloride based cleaners, or cleaners containing quaternary salts. Never use hydrochloric acid (muriatic acid) on stainless steel.

Always follow appropriate state or local health (hygiene) regulations regarding all applicable cleaning and sanitation requirements for foodservice equipment.

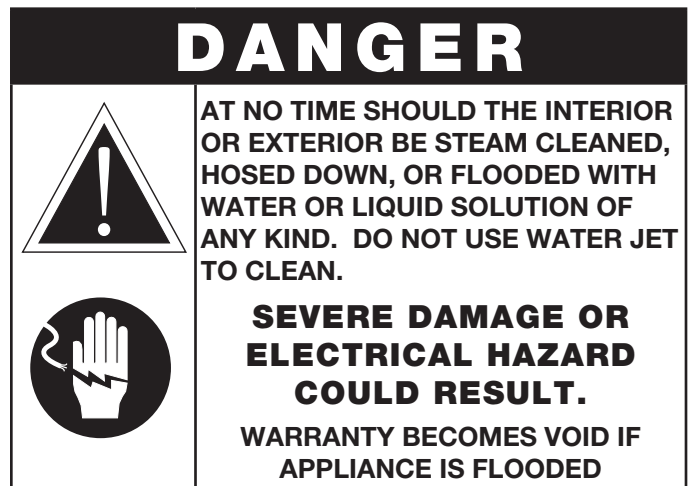
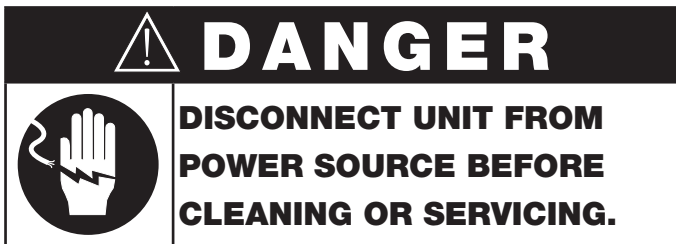

SANITATION

Food flavor and aroma are usually so closely related that it is difficult, if not impossible, to separate them. There is also an important, inseparable relationship between cleanliness and food flavor. Cleanliness, top operating efficiency, and appearance of equipment contribute considerably to savory, appetizing foods. Good equipment that is kept clean, works better and lasts longer.

Most food imparts its own particular aroma and many foods also absorb existing odors. Unfortunately, during this absorption there is no distinction between GOOD and BAD odors. The majority of objectionable flavors and odors troubling food service operations are caused by bacteria growth. Sourness, rancidity, mustiness, stale or other OFF flavors are usually the result of germ activity.

The easiest way to insure full, natural food flavor is through comprehensive cleanliness. This means good control of both visible soil (dirt) and invisible soil (germs). A thorough approach to sanitation will provide essential cleanliness. It will assure an attractive appearance of equipment, along with maximum efficiency and utility. More importantly, a good sanitation program provides one of the key elements in the prevention of food-borne illnesses.

A controlled holding environment for prepared foods is just one of the important factors involved in the prevention of food-borne illnesses. Temperature monitoring and control during receiving, storage, preparation, and the service of foods are of equal importance.

The most accurate method of measuring safe temperatures of both hot and cold foods is by internal product temperature. A quality thermometer is an effective tool for this purpose, and should be routinely used on all products that require holding at a specific temperature.

A comprehensive sanitation program should focus on the training of staff in basic sanitation procedures. This includes personal hygiene, proper handling of raw foods, cooking to a safe internal product temperature, and the routine monitoring of internal temperatures from receiving through service.

Most food-borne illnesses can be prevented through proper temperature control and a comprehensive program of sanitation. Both these factors are important to build quality service as the foundation of customer satisfaction. Safe food handling practices to prevent food-borne illness is of critical importance to the health and safety of your customers.

HACCP, an acronym for Hazard Analysis (at) Critical Control Points, is a quality control program of operating procedures to assure food integrity, quality, and safety. Taking steps necessary to augment food safety practices is both cost effective and relatively simple. While HACCP guidelines go far beyond the scope of this manual, additional information is available by contacting:

**CENTER FOR FOOD SAFETY AND APPLIED
NUTRITION FOOD AND DRUG ADMINISTRATION
1-888-SAFEFOOD**

INTERNAL FOOD PRODUCT TEMPERATURES		
HOT FOODS		
DANGER ZONE	40° TO 140°F	(4° TO 60°C)
CRITICAL ZONE	70° TO 120°F	(21° TO 49°C)
SAFE ZONE	140° TO 165°F	(60° TO 74°C)
COLD FOODS		
DANGER ZONE	ABOVE 40°F	(ABOVE 4°C)
SAFE ZONE	36° TO 40°F	(2° TO 4°C)
FROZEN FOODS		
DANGER ZONE	ABOVE 32°F	(ABOVE 0°C)
CRITICAL ZONE	0° TO 32°F	(-18° TO 0°C)
SAFE ZONE	0°F or below	(-18°C or below)

SERVICE

THERMOSTAT ACCURACY

The electronic thermostat is a precise instrument and is designed to offer trouble free service. If you suspect the temperature inside the holding compartment does not match the temperature indicated on the digital display, follow the instructions listed below.

1. Check to make certain the unit voltage matches the power source. A power source less than that required to operate the unit will result in inaccurate temperatures.
2. Verify the temperature inside the holding compartment with a quality thermal indicator.
 - a. With the exception of the wire shelves, completely empty the holding compartment.
 - b. Make certain the holding cabinet sensor, located inside the holding compartment at the left side of the unit, is completely clean.
 - c. Suspend the thermal indicator in the center of the holding compartment.
 - d. Allow the temperature set on the electronic thermostat to stabilize for a minimum of one hour before comparing the digital display with the reading on the thermal indicator.

DO NOT OPEN THE CABINET DOOR(S) DURING THE TEMPERATURE STABILIZATION PERIOD.

If the reading on the thermal indicator does not match the digital display, there may be a problem with the air sensor. See troubleshooting guide in this manual; or call the factory service department for advice.



DANGER



DISCONNECT UNIT FROM POWER SOURCE BEFORE CLEANING OR SERVICING.

CAUTION

THIS SECTION IS PROVIDED FOR THE ASSISTANCE OF QUALIFIED SERVICE TECHNICIANS ONLY AND IS NOT INTENDED FOR USE BY UNTRAINED OR UNAUTHORIZED SERVICE PERSONNEL.



TROUBLESHOOTING

This section is provided for the assistance of qualified technicians only and is not intended for use by untrained or unauthorized service personnel. If your Alto-Shaam® unit is not operating properly, check the following before calling your Authorized Alto-Shaam Service Agent:

- Check that there is power flow to the unit and circuit breaker switch at back of unit is turned on. *Do not attempt to repair or service the holding cabinet beyond this point. Contact Alto-Shaam for the nearest authorized service agent. Repairs made by any other service agents without prior authorization by Alto-Shaam® will void the warranty on the unit.*



DANGER



DISCONNECT UNIT FROM POWER SOURCE BEFORE CLEANING OR SERVICING.

CAUTION

THIS SECTION IS PROVIDED FOR THE ASSISTANCE OF QUALIFIED SERVICE TECHNICIANS ONLY AND IS NOT INTENDED FOR USE BY UNTRAINED OR UNAUTHORIZED SERVICE PERSONNEL.

SERVICE

TROUBLESHOOTING

Error Code	Description	Possible Cause
E-10	Cavity air sensor shorted	Cavity air sensor reading < 5°F. Verify sensor integrity. See sensor test instructions below.
E-11	Cavity air sensor open	Cavity air sensor reading > 517°F. Verify sensor integrity. See sensor test instructions below.
E-20	Product probe is shorted <i>Oven will cook in time only</i>	Product probe reading < 5°F. Verify sensor integrity. See sensor test instructions below.
E-21	Product probe is open <i>Oven will cook in time only</i>	Product Probe reading > 517°F. Verify sensor integrity. See sensor test instructions below.
E-30	Under temperature	Unit has not reached set-point for more than 90 minutes.
E-31	Over temperature	Unit has been higher than 25°F above the maximum cavity set-point for more than 2 minutes. Note: Holding Cabinets with this error code are more than 145°F higher than the maximum set-point.
E-50	Temp. measurement error	Contact factory.
E-51	Temp. measurement error	Contact factory.
E-60	Real time clock error	Data set to factory default. Ensure that date and time are correct if applicable.
E-61	Real time clock error	Contact factory.
E-78	Voltage low	Voltage below 90 VAC on a 125 VAC unit, or below 190 VAC on a 208-240 VAC unit. Correct voltage.
E-79	Voltage high	Voltage over 130 VAC on a 125 VAC unit, or over 250 VAC on a 208-240 VAC unit. Correct voltage.
E-80	EEPROM Error	Ensure that all temperatures and times are properly set. Contact factory if problem persists.
E-81	EEPROM Error	Contact factory.
E-82	EEPROM Error	Contact factory.
E-83	EEPROM Error	Contact factory.
E-85	EEPROM Error	All timers, if previously on, are now off. Possible bad EEPROM.
E-86	EEPROM Error	Stored HACCP memory corrupted. HACCP Address reset to 1. Possible bad EEPROM. Contact factory if problem persists.
E-87	EEPROM Error	Stored offsets corrupted. Offsets reset to 0. Control may need a recalibration. Possible bad EEPROM. Contact factory if problem persists.
E-88	EEPROM Error	All timer set-points are reset to 1 minute. Timers, if previously on, are now off. Possible bad EEPROM.
E-90	Button stuck	A button has been held down for >60 seconds. Adjust control. Error will reset when the problem has been resolved.
E-dS	Datakey error	Datakey digital signature incompatible. Cycle power, and install compatible Datakey if error persists.
E-dT	Datakey error	Datakey incompatible with control. Install compatible Datakey.
E-du	Datakey unplugged	Install Datakey and cycle power to control to clear error.

Note: If in doubt, always cycle the power to the control and contact factory if the problem persists.

To test probe and air sensor:

Test probe and air sensor by placing sensor in ice water bath and using an ohmmeter set on the ohm scale. The reading should be 100 ohms resistance. If it is more than 2 ohms higher or lower, sensor needs to be replaced.

SERVICE

EXTERIOR PARTS - SINGLE COMPARTMENT, SIMPLE CONTROL A

MODEL >		500-S		750-S		1000-S		1200-S	
ITEM	DESCRIPTION	PART NO.	QTY	PART NO.	QTY	PART NO.	QTY	PART NO.	QTY
1*	NON-PRODUCT PROBE SEAL	1006871	1	1006871	1	1006871	1	1006871	1
2	CASTER SPACER	1007145	12	1007145	12	1007145	12	1007145	12
3	BRACKET, SENSOR MTG.	1008272	1	1008272	1	1008272	1	1008272	1
4	BOTTOM PANEL	1010774	1	1010394	1	1009941	1	1011650	1
5*	INNER BACK PANEL	1011938	1	1011861	1	1011529	1	1011654	1
6	REAR TRIM	1011944	1	1011873	1	1011618	1	1011752	1
7	SIDE PANEL	1011945	2	1011871	2	1011619	2	1011759	2
8	BONNET TOP COVER	1011946	1	1011872	1	1011534	1	1011653	1
9	BREAKER SWITCH CUTOFF COVER	1011697	1	1011697	1	1011697	1	1011697	1
10	FRONT TRIM, CONTROL	5013104	1	5012940	1	5012285	1	5012731	1
11	ELEC CHASSIS	5012122	1	5012122	1	5012122	1	5012122	1
12	INSULATION	IN-22364	1	IN-22364	1	IN-22364	1	IN-22364	1
13	DOOR ASSEMBLY	5013132	1	5012938	1	5012801	1	5012663	1
14	BLOCK, SENSOR	BK-27878	1	BK-27878	1	BK-27878	1	BK-27878	1
15	T-BLOCK	BK-3019	1	BK-3019	1	BK-3019	1	BK-3019	1
16	BUSHING, 1 1/8" SNAP	BU-3378	4	BU-3378	4	BU-3378	4	BU-3378	4
17	BUSHING, STRAIGHT, STRAIN RELIEF	BU-3964	1	BU-3964	1	BU-3964	1	BU-3964	1
18	CONTROL	CC-34970	1	CC-34970	1	CC-34970	1	CC-34970	1
19	CORDSET, 120V	CD-3232	1	CD-3232	1	CD-3232	1	CD-3232	1
	CORDSET, 208-240V	CD-3551	1	CD-3551	11	CD-3551	1	CD-3551	1
	CORDSET, 230V	CD-3922	1	CD-3922	1	CD-3922	1	CD-3922	1
20	CASTER, 1.5" STEM, RIGID 5" WHL	CS-24874	2	CS-24874	2	CS-24874	2	CS-24874	2
21	CASTER, 1.5" STEM, 5" SWIV WHL, w/BRK-	CS-24875	2	CS-24875	2	CS-24875	2	CS-24875	2
22	GASKETS, ADHESIVE, .125X.375 [lin ft]	GS-23622	1	GS-23622	1	GS-23622	1	GS-23622	1
23	HANDLE, OFFSET MAG LATCH	HD-27080	1	HD-27080	1	HD-27080	1	HD-27080	1
24	HINGE, 1-3/8" OFFSET, PAIR, CHROME	HG-22338	2	HG-22338	2	HG-22338	1	HG-22338	1
25*	NUT, M4-0.7 HEX 18-8	NU-22286	2	NU-22286	2	NU-22286	2	NU-22286	2
26*	NUT, HEX #8-32	NU-2296	2	NU-2296	2	NU-2296	2	NU-2296	2
27*	NUT, 6-32 HEX, S/S	NU-2361	4	NU-2361	4	NU-2361	4	NU-2361	4
28*	PANEL, OVERLAY	PE-29399	1	PE-29398	1	PE-29396	1	PE-29397	1
29*	PLUG, 3/8" HOLE	PG-25574	2	PG-25574	2	PG-25574	2	PG-25574	2
30	SENSOR, OVEN TEMPERATURE	PR-34494	1	PR-34494	1	PR-34494	1	PR-34494	1
31	RIVET, BLIND, #44, STNLS	RI-2100	24	RI-2100	24	RI-2100	24	RI-2100	24
32	SCREW, 10-32 X 3/4 PHILLIPS PAN HD	SC-2071	2	SC-2071	2	SC-2071	2	SC-2071	2
33	SCREW, 10-32 X 3/4, NF PHIL, FLAT M/S, 18-8 S/S	SC-2072	6	SC-2072	6	SC-2072	6	SC-2072	6
34	SCREW, 10-32 X 1-1/2, NF, PHIL, FLAT M/S, 18-8 S/S	SC-2073	6	SC-2073	6	SC-2073	6	SC-2073	6
35*	SCREW, 10-32 X 1/4 PAN HD GROUND	SC-2190	1	SC-2190	1	SC-2190	1	SC-2190	1
36*	SCREWS, M4-0.7X6MM PHIL	SC-22271	2	SC-22271	2	SC-22271	2	SC-22271	2
37	SCREW, 6-32 X 1/2, NC PHIL, FLAT	SC-2239	2	SC-2239	2	SC-2239	2	SC-2239	2
38*	SCREW, 1/4-20 X 1/2, NC SLOT RND	SC-2332	4	SC-2332	4	SC-2332	4	SC-2332	4
39*	SCREW, 6-32 X 1 1/4" ROUND HD	SC-2365	2	SC-2365	2	SC-2365	2	SC-2365	2
40	SCREW, 10-32 X 1-3/4, NF, PHIL, FLAT M/S, 18-8 S/S	SC-29387	4	SC-29387	4	SC-29387	4	SC-29387	4
41*	SPACER, SNAP-IN, 7/16", CONTROL	SP-29392	6	SP-29392	6	SP-29392	6	SP-29392	6
42*	SHELF, CHROME PLATED	SH-2107	2	SH-2105	2	---	---	---	---
43	SIDE RACK	SR-28402	2	SR-28404	2	SR-2120	2	---	---
	*PAN SLIDES	---	---	---	---	---	---	SR-24447	8
	*PAN SLIDE RAIL	---	---	---	---	---	---	1011741	4
44	SWITCH, ROCKER, 125-277V, 20A	SW-34769	1	SW-34769	1	SW-34769	1	SW-34769	1
45*	TAPE, 1" WIDE X 25 MIL VHB	TA-24637	9	TA-24637	9	TA-24637	9	TA-24637	18
46*	WASHER, 6-32, FLAT, NYL	WS-23148	4	WS-23148	4	WS-23148	4	WS-23148	4
47*	WASHER, STAR LOCK	WS-2467	1	WS-2467	1	WS-2467	1	WS-2467	1

*NOT SHOWN

SERVICE

EXTERIOR VIEW - DOUBLE COMPARTMENT, SIMPLE CONTROL (1000-UP SHOWN)

B

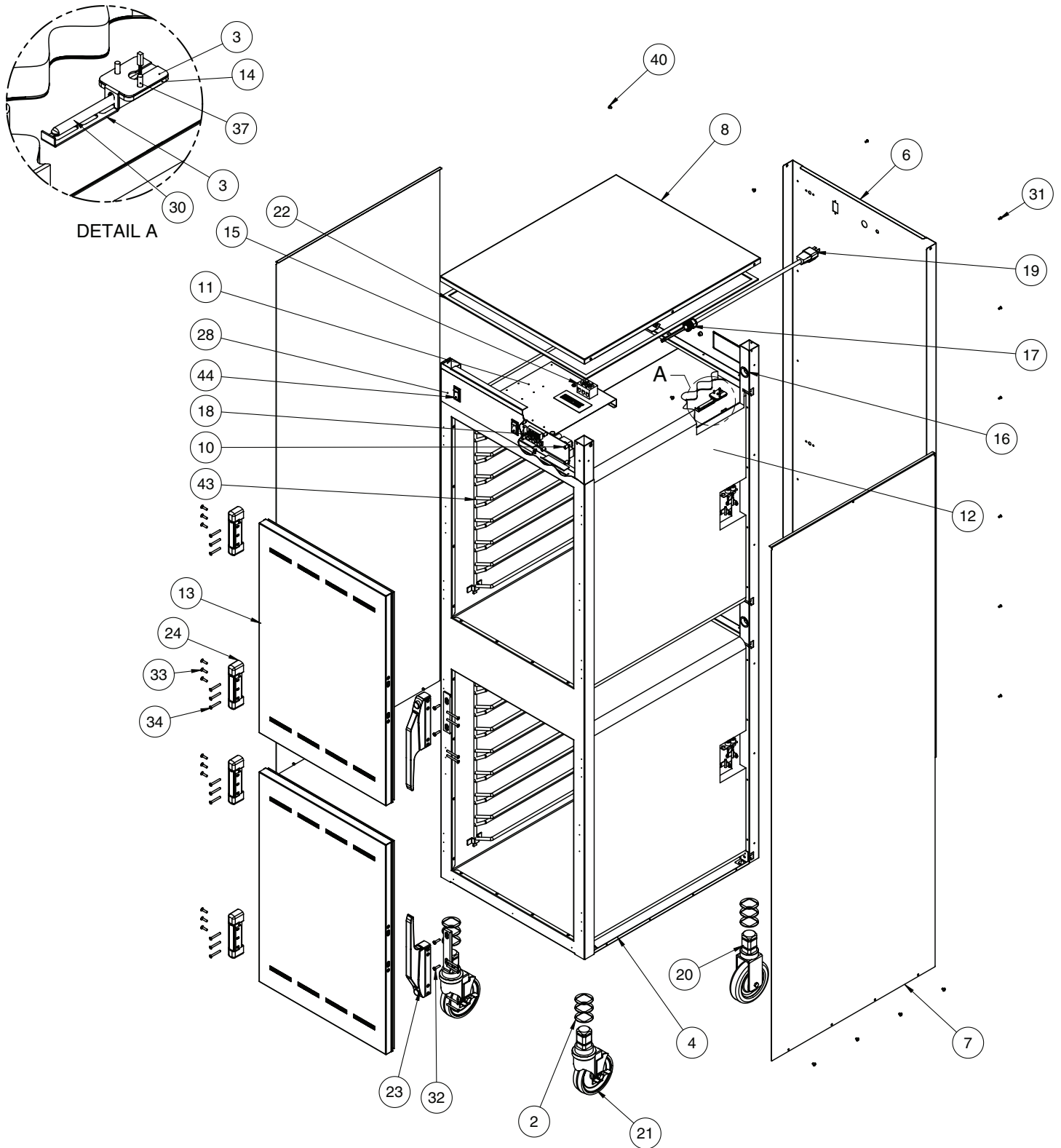

Part numbers and drawings are subject to change without notice.

SERVICE

EXTERIOR PARTS - DOUBLE COMPARTMENT, SIMPLE CONTROL B

ITEM	DESCRIPTION	MODEL >		1000-UP		1200-UP	
		PART NO.	QTY	PART NO.	QTY	PART NO.	QTY
1*	NON-PRODUCT PROBE SEAL	1006871	2	1006871	2	1006871	2
2	CASTER SPACER	1007145	12	1007145	12	1007145	12
3	BRACKET, SENSOR MTG.	1008272	2	1008272	2	1008272	2
4	BOTTOM PANEL	1009941	1	1011650	1	1011650	1
5*	INNER BACK PANEL	1011529	2	1011654	2	1011654	2
6	REAR TRIM	1011532	1	1011652	1	1011652	1
7	SIDE PANEL	1011533	2	1011533	2	1011533	2
8	BONNET TOP COVER	1011534	1	1011653	1	1011653	1
9*	BREAKER SWITCH CUTOFF COVER	1011697	1	1011397	1	1011397	1
10	FRONT TRIM, CONTROL	5012113	1	5012345	1	5012345	1
11	ELEC CHASSIS	5012122	1	5012122	1	5012122	1
12	INSULATION	IN-22364	1	IN-22364	1	IN-22364	1
13	DOOR ASSEMBLY	5012801	2	5012663	2	5012663	2
14	BLOCK, SENSOR	BK-27878	2	BK-27878	2	BK-27878	2
15	T-BLOCK	BK-3019	1	BK-3019	1	BK-3019	1
16	BUSHING, 1 1/8" SNAP	BU-3378	8	BU-3378	8	BU-3378	8
17	BUSHING, STRAIGHT, STRAIN RELIEF	BU-3964	1	BU-3964	1	BU-3964	1
18	CONTROL	CC-34970	2	CC-34970	2	CC-34970	2
19	CORDSET, 120V	CD-33824	1	CD-33824	1	CD-33824	1
	CORDSET, 208-240V	CD-3551	1	CD-3551	1	CD-3551	1
	CORDSET, 230V	CD-3922	1	CD-3922	1	CD-3922	1
20	CASTER, 1.5" STEM, RIGID 5" WHL	CS-24874	2	CS-24874	2	CS-24874	2
21	CASTER, 1.5" STEM, 5" SWIV WHL, w/BRK	CS-24875	2	CS-24875	2	CS-24875	2
22	GASKETS, ADHESIVE, .125X.375 [lin ft]	GS-23622	1	GS-23622	1	GS-23622	1
23	HANDLE, OFFSET MAG LATCH	HD-27080	2	HD-27080	2	HD-27080	2
24	HINGE, 1-3/8 OFFSET, PAIR, CHROME	HG-22338	2	HG-22338	2	HG-22338	2
25*	NUT, M4-0.7 HEX 18-8	NU-22286	4	NU-22286	4	NU-22286	4
26*	NUT, HEX #8-32	NU-2296	2	NU-2296	2	NU-2296	2
27*	NUT, 6-32 HEX, S/S	NU-2361	8	NU-2361	8	NU-2361	8
28	PANEL, OVERLAY	PE-29394	1	PE-29395	1	PE-29395	1
29*	PLUG, 3/8" HOLE	PG-25574	3	PG-25574	3	PG-25574	3
30	SENSOR, OVEN TEMPERATURE	PR-34494	2	PR-34494	2	PR-34494	2
31*	RIVET, BLIND, #44, STNLS	RI-2100	44	RI-2100	44	RI-2100	44
32	SCREW, 10-32 X 3/4 PHILLIPS PAN HD	SC-2071	4	SC-2071	4	SC-2071	4
33	SCREW, 10-32 X 3/4, NF PHIL, FLAT M/S, #18-8 S/S	SC-2072	12	SC-2072	12	SC-2072	12
34	SCREW, 10-32 X 1-1/2, NF, PHIL, FLAT M/S, 18-8 S/S	SC-2073	12	SC-2073	12	SC-2073	12
35*	SCREW, 10-32 X 1/4 PAN HD GROUND	SC-2190	1	SC-2190	1	SC-2190	1
36*	SCREWS, M4-0.7X6MM PHIL	SC-22271	4	SC-22271	4	SC-22271	4
37	SCREW, 6-32 X 1/2, NC PHIL, FLAT	SC-2239	4	SC-2239	4	SC-2239	4
38*	SCREW, 1/4-20 X 1/2, NC SLOT RND	SC-2332	4	SC-2332	4	SC-2332	4
39*	SCREW, 6-32 X 1 1/4" ROUND HD	SC-2365	2	SC-2365	2	SC-2365	2
40	SCREW, 8-32 X 1/4" PHIL	SC-2459	30	SC-2459	32	SC-2459	32
41*	SCREW, 10-32 X 1-3/4, NF, PHIL, FLAT M/S, 18-8 S/S	SC-29387	8	SC-29387	8	SC-29387	8
42*	SPACER, SNAP-IN, 7/16", CONTROL	SP-29392	12	SP-29392	12	SP-29392	12
43	SIDE RACK	SR-2120	4	---	---	---	---
	*PAN SLIDE	---	---	SR-24447	16	SR-24447	16
	*PAN SLIDE RAIL	---	---	1011741	8	1011741	8
44	SWITCH, ROCKER, 125-277V, 20A	SW-34769	2	SW-34769	2	SW-34769	2
45*	TAPE, 1" WIDE X 25 MIL VHB	TA-24637	2	---	---	---	---
46*	WASHER, 6-32, FLAT, NYL	WS-23148	8	WS-23148	8	WS-23148	8
47*	WASHER, STAR LOCK	WS-2467	1	WS-2467	1	WS-2467	1

*NOT SHOWN

SERVICE

EXTERIOR VIEW - SINGLE COMPARTMENT, DELUXE CONTROL (C) (1000-S Shown)

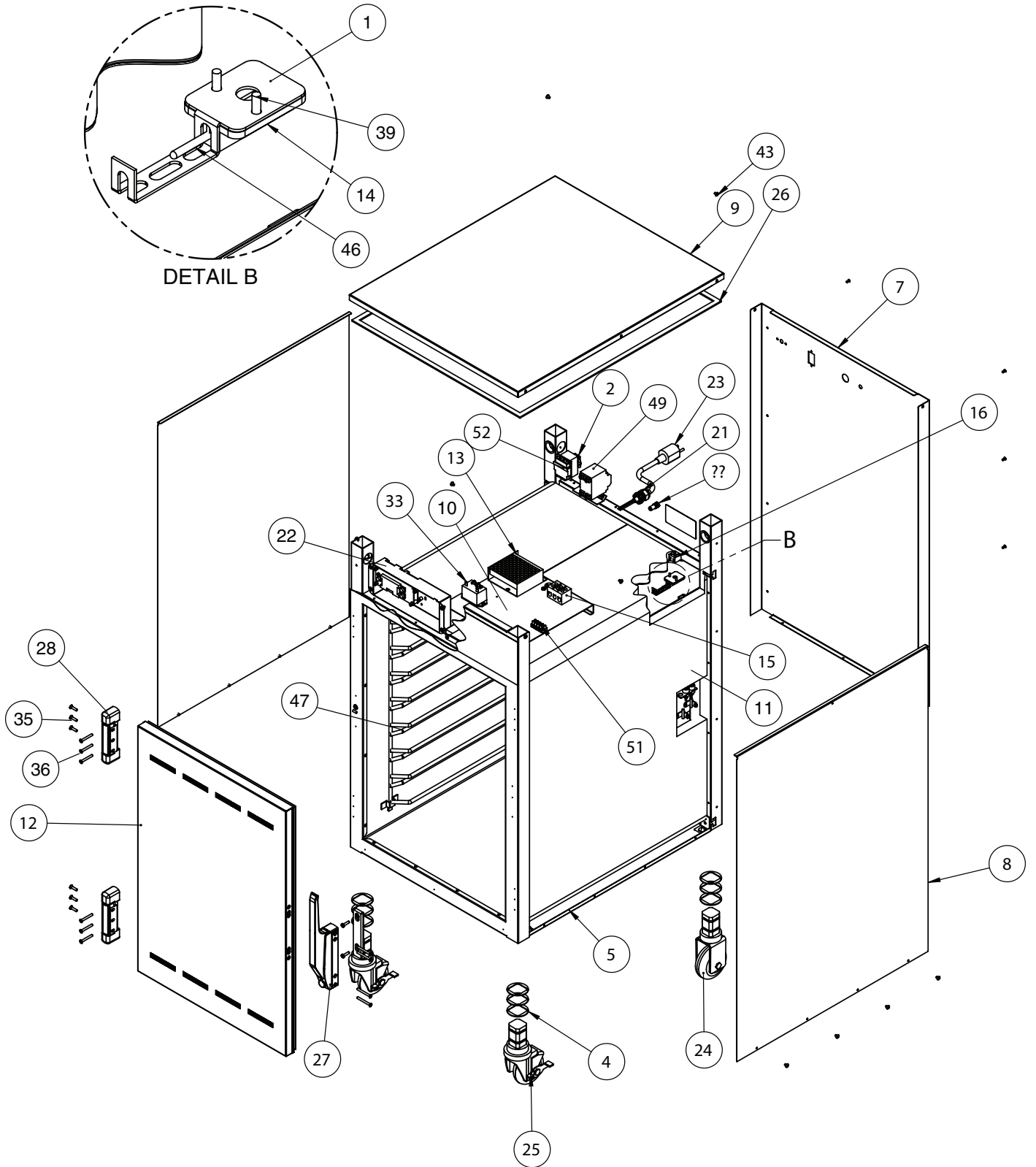

Part numbers and drawings are subject to change without notice.

SERVICE

EXTERIOR PARTS - SINGLE COMPARTMENT, DELUXE CONTROL C

MODEL >		500-S		750-S		1000-S		1200-S	
ITEM	DESCRIPTION	PART NO.	QTY	PART NO.	QTY	PART NO.	QTY	PART NO.	QTY
1	SENSOR GUARD	1493	1	1493	1	1493	1	1493	1
2	HI-LIMIT PROTECTION COVER	1003936	1	1003936	1	1003936	1	1003936	1
3*	NON-PRODUCT PROBE SEAL	1006871	1	1006871	1	1006871	1	1006871	1
4	CASTER SPACER	1007145	12	1007145	12	1007145	12	1007145	12
5	BOTTOM PANEL	1010774	1	1010394	1	1009941	1	1011650	1
6*	INNER BACK PANEL	1011938	1	1011861	1	1011529	1	1011654	1
7	REAR TRIM	1011944	1	1011873	1	1011618	1	1011752	1
8	SIDE PANEL	1011945	2	1011871	2	1011619	2	1011759	2
9	BONNET TOP COVER	1011946	1	1011872	1	1011534	1	1011653	1
10	ELEC CHASSIS	5012122	1	5012122	1	5012122	1	5012122	1
11	INSULATION	IN-22364	1	IN-22364	1	IN-22364	1	IN-22364	1
12	DOOR ASSEMBLY	5013132	1	5012938	1	5012801	1	5012663	1
13	POWER SUPPLY BOARD	BA-33554	1	BA-33554	1	BA-33554	1	BA-33554	1
14	BLOCK, MOUNTING SENSOR	BK-24427	1	BK-24427	1	BK-24427	1	BK-24427	1
15	T-BLOCK	BK-3019	1	BK-3019	1	BK-3019	1	BK-3019	1
16	TERMINAL BLOCK, SENSOR	BK-33546	1	BK-33546	1	BK-33546	1	BK-33546	1
17*	BEEPER	BP-3567	1	BP-3567	1	BP-3567	1	BP-3567	1
18*	BUSHING, 1/2" HOLE	BU-3006	1	BU-3006	1	BU-3006	1	BU-3006	1
19*	BUSHING, 1 1/8" SNAP	BU-3378	4	BU-3378	4	BU-3378	4	BU-3378	4
20*	BUSHING, 3/8" HOLE, BLACK	BU-3419	1	BU-3419	1	BU-3419	1	BU-3419	1
21	BUSHING, STRAIGHT, STRAIN RELIEF	BU-3964	1	BU-3964	1	BU-3964	1	BU-3964	1
22	CONTROL W/O TIMERS	5012946	1	5012946	1	5012946	1	5012946	1
23	CORDSET, 120V	CD-3232	1	CD-3232	1	CD-3232	1	CD-3232	1
	CORDSET, 208-240V	CD-3551	1	CD-3551	1	CD-3551	1	CD-3551	1
	CORDSET, 230V	CD-3922	1	CD-3922	1	CD-3922	1	CD-3922	1
24	CASTER, 1.5" STEM, RIGID 5" WHL	CS-24874	2	CS-24874	2	CS-24874	2	CS-24874	2
25	CASTER, 1.5" STEM, 5" SWIV WHL, w/BRK	CS-24875	2	CS-24875	2	CS-24875	2	CS-24875	2
26*	GASKETS, ADHESIVE, .125X.375 [lin ft]	GS-23622	8	GS-23622	8	GS-23622	8	GS-23622	1
27	HANDLE, OFFSET MAG LATCH	HD-27080	1	HD-27080	1	HD-27080	1	HD-27080	1
28	HINGE, 1-3/8 OFFSET, PAIR, CHROME	HG-22338	1	HG-22338	1	HG-22338	1	HG-22338	1
29*	NUT, HEX #8-32	NU-2296	2	NU-2296	2	NU-2296	2	NU-2296	2
30*	PANEL, OVERLAY	PE-27934	1	PE-27267	1	PE-27082	1	PE-28366	1
31*	PLUG, 3/8" HOLE	PG-25574	3	PG-25574	3	PG-25574	3	PG-25574	3
32*	RIVET, BLIND, #44, STNLS	RI-2100	24	RI-2100	24	RI-2100	24	RI-2100	24
33	RELAY	RL-33558	1	RL-33558	1	RL-33558	1	RL-33558	1
34*	SCREW, 10-32 X 3/4 PHILLIPS PAN HD	SC-2071	2	SC-2071	2	SC-2071	2	SC-2071	2
35	SCREW, 10-32 X 3/4, NF PHIL, FLAT M/S, #18-8 S/S	SC-2072	6	SC-2072	6	SC-2072	6	SC-2072	6
36	SCREW, 10-32 X 1-1/2, NF, PHIL, FLAT M/S, 18-8 S/S	SC-2073	6	SC-2073	6	SC-2073	6	SC-2073	6
37*	SCREW, 10-32 X 1/4 PAN HD GROUND	SC-2190	1	SC-2190	1	SC-2190	1	SC-2190	1
38*	SCREWS, M4-0.7 X 6MM PHIL	SC-22271	2	SC-22271	2	SC-22271	2	SC-22271	2
39	SCREW, 6-32 X 1/2, NC PHIL, FLAT	SC-2239	2	SC-2239	2	SC-2239	2	SC-2239	2
40*	SCREW 6-32 X 1/4 PAN HD	SC-22500	2	SC-22500	2	SC-22500	2	SC-22500	2
41*	SCREW, 1/4-20 X 1/2", NC SLOT RND	SC-2332	4	SC-2332	4	SC-2332	4	SC-2332	4
42*	SCREW, 6-32 X 1 1/4" ROUND HD	SC-2365	2	SC-2365	2	SC-2365	2	SC-2365	2
43	SCREW, 8-32 x 1/4" PHIL	SC-2459		SC-2459		SC-2459	27	SC-2459	31
44*	SCREW, 6-32 X 1/2, NC PHIL TRUSS M/S 18-8 S/S	SC-2472	8	SC-2472	8	SC-2472	8	SC-2472	8
45*	SCREW, 10-32 X 1-3/4, NF, PHIL, FLAT M/S, 18-8 S/S	SC-29387	4	SC-29387	4	SC-29387	4	SC-29387	4
46	SENSOR	SN-33541	1	SN-33541	1	SN-33541	1	SN-33541	1
47	*SHELF, CHROME PLATED	SH-2107	2	SH-2105	2	---	---	---	---
48	*SIDE RACK	SR-2842	2	SR-28404	2	SR-2120	2	---	---
	*PAN SLIDE, CHROME PLATED	---	---	---	---	---	---	SR-24447	8
	*PAN SLIDE RAIL	---	---	---	---	---	---	1011741	4
49*	SWITCH, REED	SW-33559	1	SW-33559	1	SW-33559	1	SW-33559	1
50	SWITCH, CIRCUIT BREAKER	SW-34077	1	SW-34077	1	SW-34077	1	SW-34077	1
51*	TAPE, 1" WIDE X 25 MIL VHB	TA-24637	2	TA-24637	2	TA-24637	2	TA-24637	2
52	TERMINAL STRIP	TM-33560	1	TM-33560	1	TM-33560	1	TM-33560	1
53*	T-STAT, HI-LIMIT	TT-33476	1	TT-33476	1	TT-33476	1	TT-33476	1
54	WASHER, STAR LOCK	WS-2467	1	WS-2467	1	WS-2467	1	WS-2467	1

*NOT SHOWN

SERVICE

EXTERIOR VIEW - DOUBLE COMPARTMENT, DELUXE CONTROL (C) (1000-UP Shown)

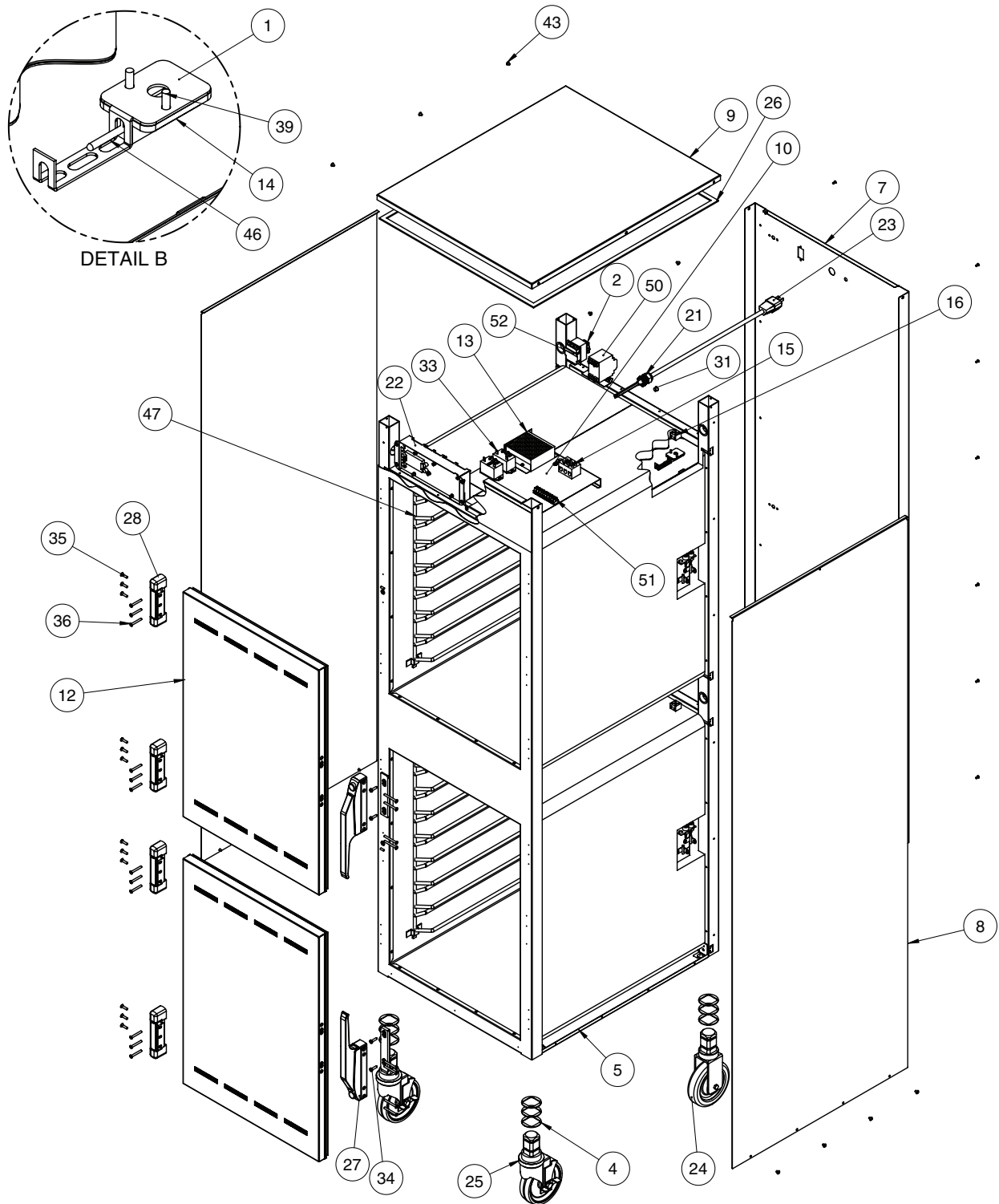

Part numbers and drawings are subject to change without notice.

SERVICE

EXTERIOR VIEW PARTS LIST - DOUBLE COMPARTMENT, DELUXE CONTROL C

ITEM	DESCRIPTION	1000-UP		1200-UP	
		PART NO.	QTY	PART NO.	QTY
1	SENSOR GUARD	1493	2	1493	2
2	HI-LIMIT PROTECTION COVER	1003936	2	1003936	2
3*	NON-PRODUCT PROBE SEAL	1006871	2	1006871	2
4	CASTER SPACER	1007145	12	1007145	12
5	BOTTOM PANEL	1009941	1	1011650	1
6*	INNER BACK PANEL	1011529	2	1011529	2
7	REAR TRIM	1011532	1	1011652	1
8	SIDE PANEL	1011533	2	1011533	2
9	BONNET TOP COVER	1011534	1	1011653	1
10	ELEC CHASSIS	5012122	1	5012122	1
11*	INSULATION	IN-22364	1	IN-22364	1
12	DOOR ASSEMBLY	5012801	2	5012663	2
13	POWER SUPPLY BOARD	BA-33554	1	BA-33554	1
14	BLOCK, MOUNTING SENSOR	BK-24427	2	BK-24427	2
15	T-BLOCK	BK-3019	1	BK-3019	1
16	TERMINAL BLOCK, SENSOR	BK-33546	3	BK-33546	3
17*	BEEPER	BP-3567	1	BP-3567	1
18*	BUSHING, 1/2" HOLE	BU-3006	1	BU-3006	1
19*	BUSHING, 1 1/8" SNAP	BU-3378	8	BU-3378	8
20*	BUSHING, 3/8" HOLE, BLACK	BU-3419	2	BU-3419	2
21	BUSHING, STRAIGHT, STRAIN RELIEF	BU-3964	1	BU-3964	1
22	CONTROL W/O TIMERS	5011153	1	5011153	1
23	CORDSET, 120V	CD-33824	1	CD-33824	1
	CORDSET, 208-240V	CD-3551	1	CD-3551	1
	CORDSET, 230V	CD-3922	1	CD-3922	1
24	CASTER, 1.5" STEM, RIGID 5" WHL	CS-24874	2	CS-24874	2
25	CASTER, 1.5" STEM, 5" SWIV WHL, w/BRK-	CS-24875	2	CS-24875	2
26	GASKETS, ADHESIVE, .125X.375 [lin ft]	GS-23622	1	GS-23622	1
27	HANDLE, OFFSET MAG LATCH	HD-27080	2	HD-27080	2
28	HINGE, 1-3/8 OFFSET, PAIR, CHROME	HG-22338	2	HG-22338	2
29*	NUT, HEX #8-32	NU-2296	2	NU-2296	2
30*	PANEL, OVERLAY	PE-27938	1	PE-27938	1
31	PLUG, 3/8" HOLE	PG-25574	3	PG-25574	3
32*	RIVET, BLIND, #44, STNLS	RI-2100	44	RI-2100	44
33	RELAY	RL-33558	2	RL-33558	2
34	SCREW, 10-32 X 3/4 PHILLIPS PAN HD	SC-2071	4	SC-2071	4
35	SCREW, 10-32 X 3/4, NF PHIL, FLAT M/S, #18-8 S/S	SC-2072	12	SC-2072	12
36	SCREW, 10-32X1-1/2, NF, PHIL, FLAT M/S, 18-8 S/S	SC-2073	12	SC-2073	12
37*	SCREW, 10-32 X 1/4 PAN HD GROUND	SC-2190	1	SC-2190	1
38*	SCREWS, M4-0.7X6MM PHIL	SC-22271	4	SC-22271	4
39	SCREW, 6-32 X 1/2, NC PHIL, FLAT	SC-2239	4	SC-2239	4
40*	SCREW 6-32 X 1/4 PAN HD	SC-22500	2	SC-22500	2
41*	SCREW, 1/4-20 X 1/2", NC SLOT RND	SC-2332	4	SC-2332	4
42*	SCREW, 6-32 X 1 1/4" ROUND HD	SC-2365	2	SC-2365	2
43	SCREW, 8-32 x 1/4" PHIL	SC-2459	30	SC-2459	30
44*	SCREW, 6-32 X 1/2, NC PHIL TRUSS M/S 18-8 S/S	SC-2472	8	SC-2472	8
45*	SCREW, 10-32X1-3/4, NF, PHIL, FLAT M/S, 18-8 S/S	SC-29387	8	SC-29387	8
46	SENSOR	SN-33541	2	SN-33541	2
47*	SIDE RACK	SR-2120	4	—	—
	PAN SLIDE	—	—	SR-24447	16
	PAN SLIDE RAIL	—	—	1011741	8
48*	SWITCH, REED	SW-33559	2	SW-33559	2
49	SWITCH, CIRCUIT BREAKER	SW-34077	1	SW-34077	1
50*	TAPE, 1" WIDE X 25 MIL VHB	TA-24637	2	TA-24637	2
51	TERMINAL STRIP	TM-33560	2	TM-33560	2
52	T-STAT, HI-LIMIT	TT-33476	2	TT-33476	2
53*	WASHER, STAR LOCK	WS-2467	1	WS-2467	1

*NOT SHOWN

SERVICE

CABLE HEATING SERVICE KITS

MODEL >	500-S, 750-S, 1000-S, 1000-UP		1200-UP			
1 kit required per compartment	Kit No. 4874		Kit No. 4878 for all <u>except</u> 4000W cabinets		Kit No. 4881 for 4000W cabinets	
KIT INCLUDES:	PART NO.	QTY.	PART NO.	QTY.	PART NO.	QTY.
Cable Heating Element	CB-3044	108 feet (3292cm)	CB-3045	90 feet (2591cm)	CB-3045	210 feet (6401cm)
Ring Connector	CR-3226	4	CR-3226	4	CR-3226	12
Insulation Corner	IN-3488	1 foot (30,5cm)	IN-3488	1 foot (30,5cm)	IN-3488	1 foot (30,5cm)
Shoulder Bushing	BU-3105	4	BU-3105	4	BU-3105	12
Cup Bushing	BU-3106	4	BU-3106	4	BU-3106	12
Stud	ST-2439	4	ST-2439	4	ST-2439	12
Hex Nut	NU-2215	8	NU-2215	8	NU-2215	24
Insulating Sleeve	SL-3063	4	SL-3063	4	SL-3063	12
Electrical Tape	TA-3540	1 roll	TA-3540	1 roll	TA-3540	1 roll



DANGER



**DISCONNECT UNIT FROM
POWER SOURCE BEFORE
CLEANING OR SERVICING.**

CAUTION

**THIS SECTION IS PROVIDED FOR THE ASSISTANCE
OF QUALIFIED SERVICE TECHNICIANS ONLY AND
IS NOT INTENDED FOR USE BY UNTRAINED OR
UNAUTHORIZED SERVICE PERSONNEL.**

VIEW FROM REAR OF BONNET

(FRONT)

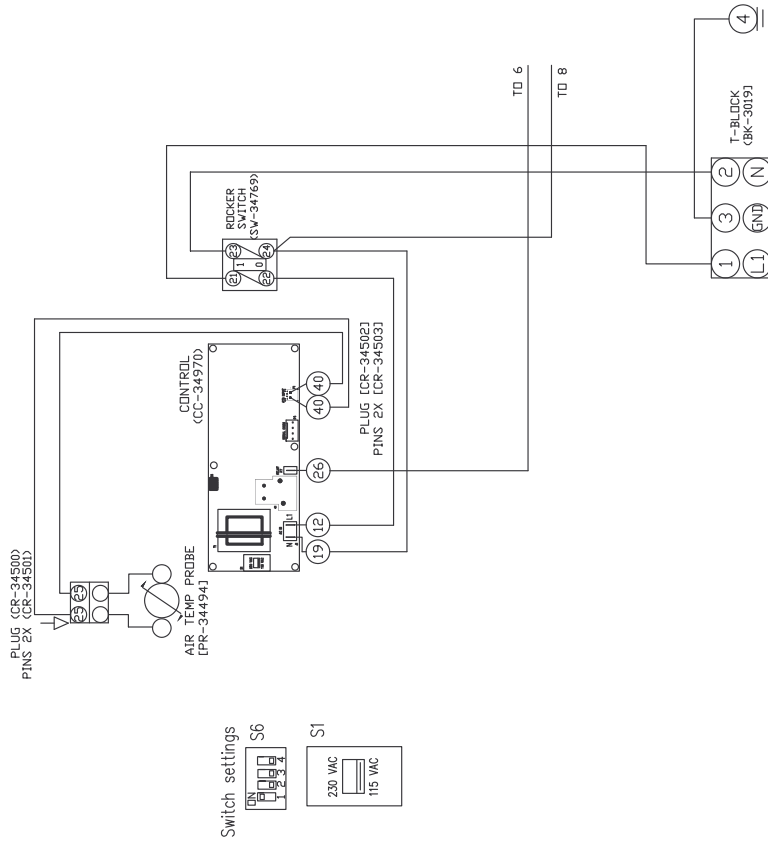

PLUG: 15A-125V
NEMA 5-15P



14/3 120V CORD SET (CD-3232)
FOR 500, 750, 1000 AND 1200

*USE CORD E3025CD FOR VBS UNITS

(REAR)

NOTE #1: ALL NUMBERS IN () =
ALTO-SHAAM PART NUMBERS
NOTE #2: SEE DRW. 5012835 FOR MAIN WIRE ASSEMBLY
SEE DRW. 5012836 FOR 120V WIRE ASSEMBLY

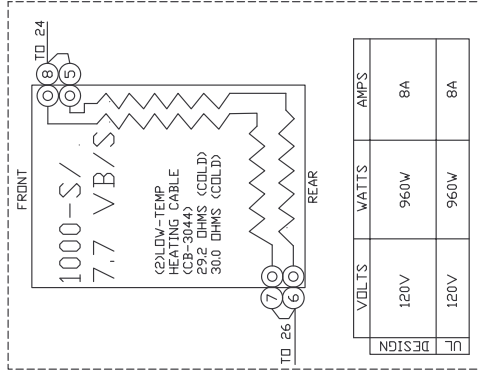
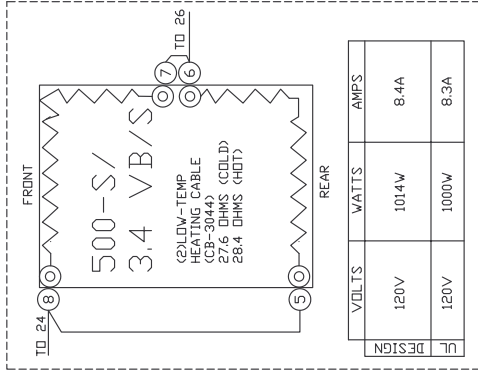
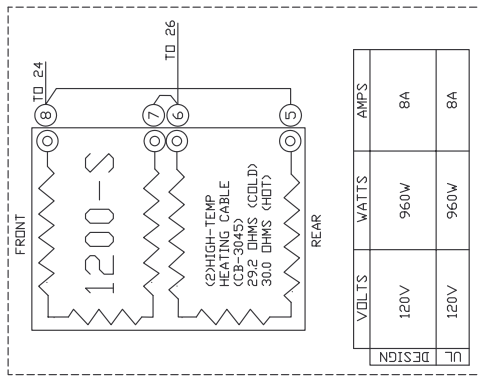
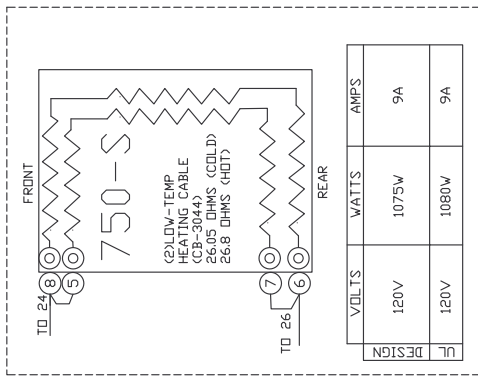

9	5904	REDUCE 1200-S WATTS	2-18-11	JPK
8	-	HTG CBL POST CHNG 1000-S	1-4-11	JPK
7	5727	NEW CONTROL	8-26-10	JPK
REV	ECO	DESCRIPTION	DATE	APP
500,750,1000,1200-S,AND 3.4,7.7VB/S, 120V 60HZ				
ALTO-SHAAM			WIRING DIAGRAM	
BY: JPK DATE: 1/16/08			DWG: 77194	
			SHEET	
			1_DF_1	

VIEW FROM REAR OF BONNET

(FRONT)

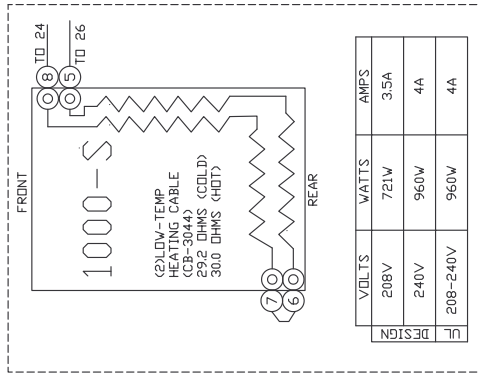
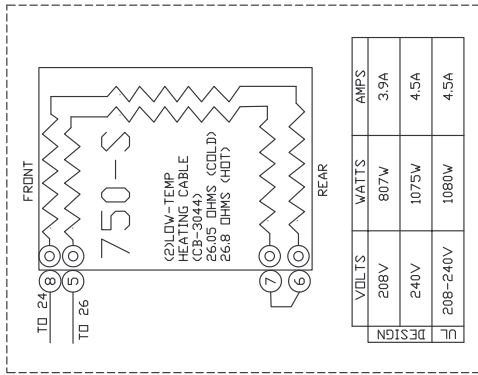
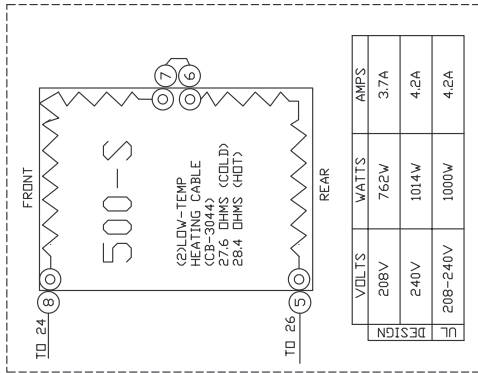
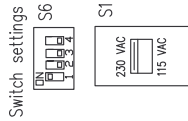
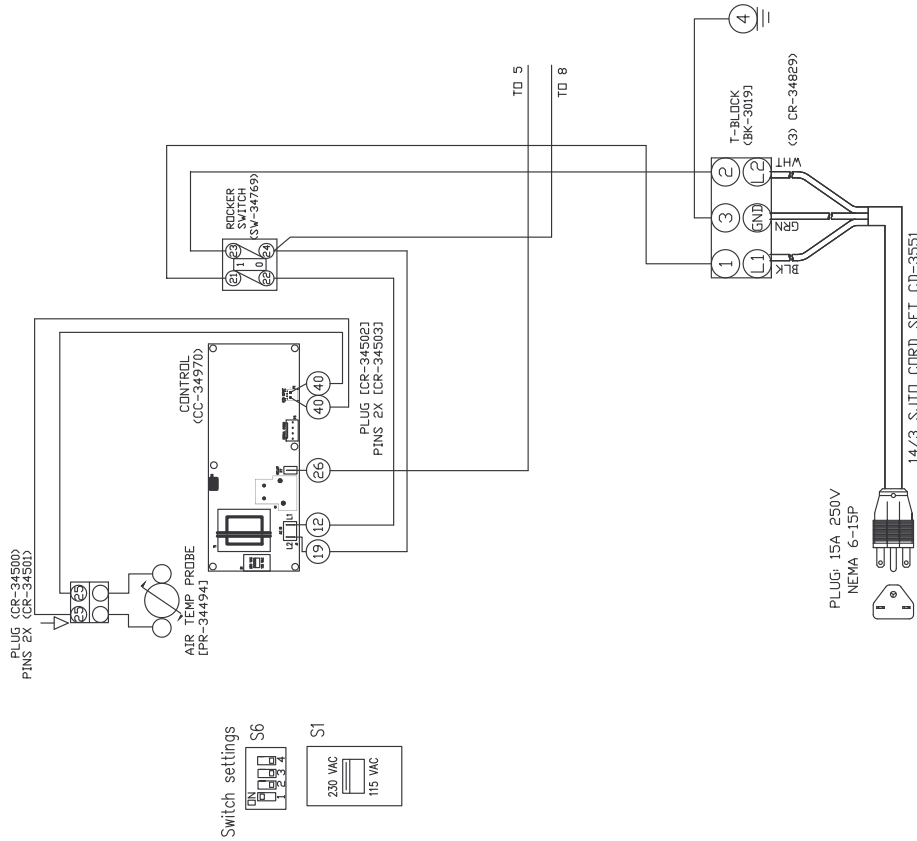

1200-S 2000W MODEL		
VOLTS	WATTS	AMPS
208V	1442W	6.9A
240V	1920W	8A
208-240V	1920W	8A

8	5904	REDUCE 1200-S WATTS	2-18-11	JPK
7	5727	FIX WIRE ASSEMBLY TYPO	1-20-10	JPK
6	-	HTG CBL POST CHNG 1000.S	1-4-11	JPK
REV	ECO	DESCRIPTION	DATE	APP
500,750,1000,1200-S 208-240V 60HZ				
ALTO-SHAAM			WIRING DIAGRAM	
BY: JPK DATE: 1/16/08			DWG: 77195	
			SHEET	
			1_OF_1	

NOTE #1: ALL NUMBERS IN () = ALTO-SHAAM PART NUMBERS

NOTE #2: SEE DRW. 5012835 FOR MAIN WIRE ASSEMBLY
SEE DRW. 5012837 FOR 208-240V WIRE ASSEMBLY
SEE DRW. 5007692 FOR HIGH WATT JUMPERS

(REAR)

VIEW FROM REAR OF BONNET

(FRONT)

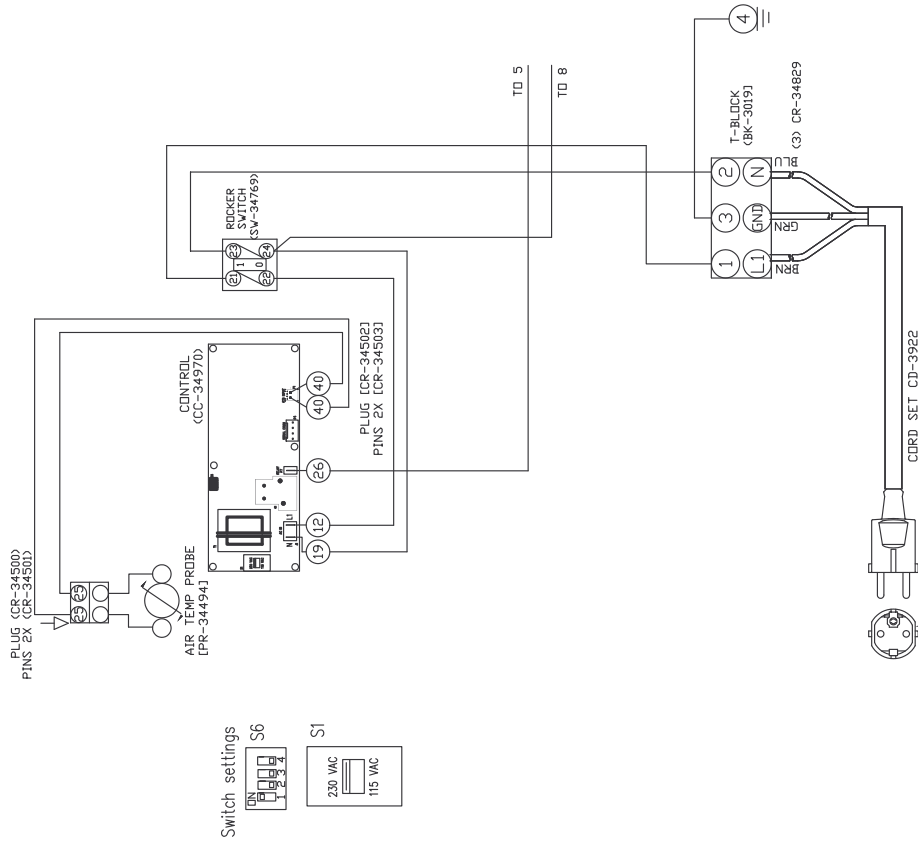

NOTE #1: ALL NUMBERS IN () = ALTO-SHAAM PART NUMBERS

NOTE #2: SEE DRW. 5012835 FOR MAIN WIRE ASSEMBLY
SEE DRW. 5012838 FOR 230V WIRE ASSEMBLY
SEE DRW. 5007692 FOR HIGH WATT JUMPERS

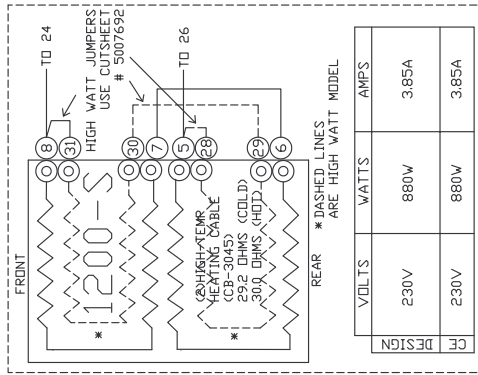
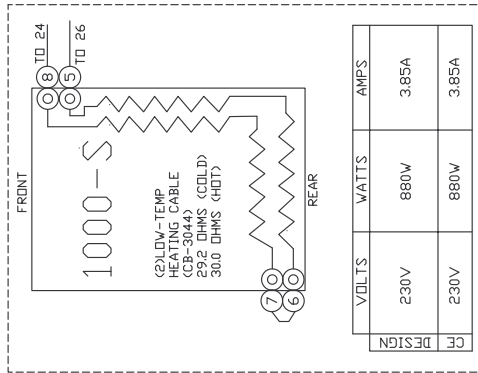
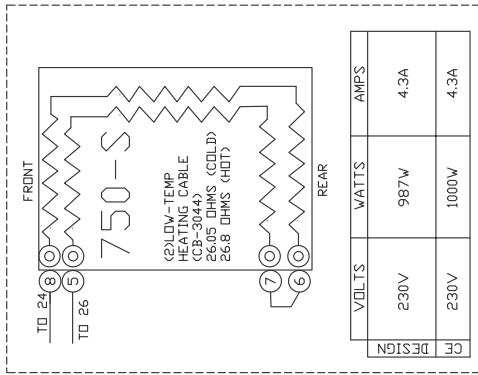
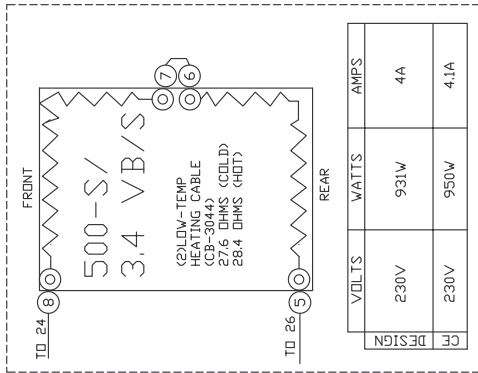

1200-S HIGH WATT MODEL					
VOLTS	WATTS	AMPS	MODEL	DATE	APP
230V	1760W	7.65A			
CE DESIGN					

WIRING DIAGRAM					
REV	ECO	DESCRIPTION	DATE	APP	JPK
11	5904	REDUCE 1200-S WATTS	2-18-11	JPK	
10	5727	FIX WIRE ASSEMBLY TYPO	1-20-10	JPK	
9	-	HTG CBL POST CHNG	1-4-11	JPK	
500,750,1000,1200-S,3,4,7,7 VB/S, 230V, 50HZ					

BY: JPK DATE: 1/16/08

ALTO-SHAAM DWG: 77196

SHEET 1 OF 1

TOP VIEW OF CABLE CONFIGURATION

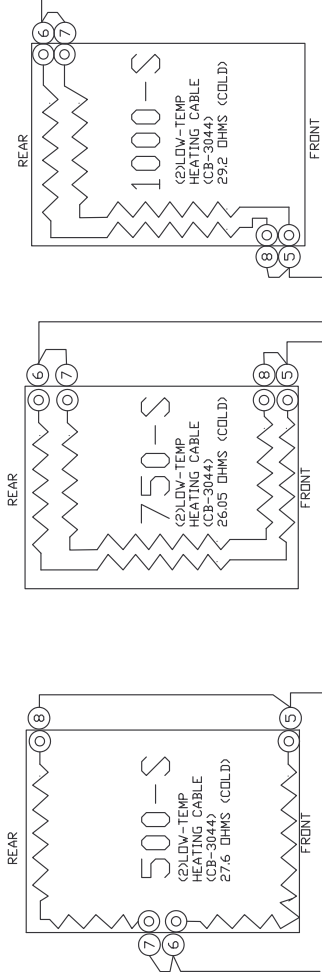

VOLTS	WATTS	AMPS
120V	1014W	8.4A
120V	1000W	8.3A

VOLTS	WATTS	AMPS
120V	1075W	8.9A
120V	1080W	9A

VOLTS	WATTS	AMPS
120V	960W	8A
120V	960W	8A

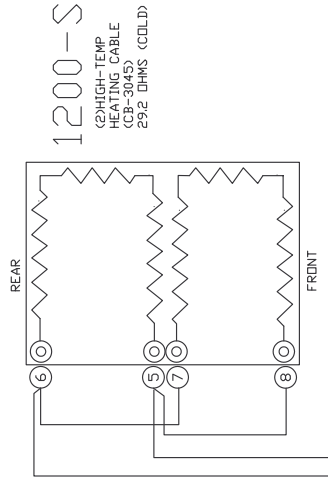

VOLTS	WATTS	AMPS
120V	960W	8A
120V	960W	8A

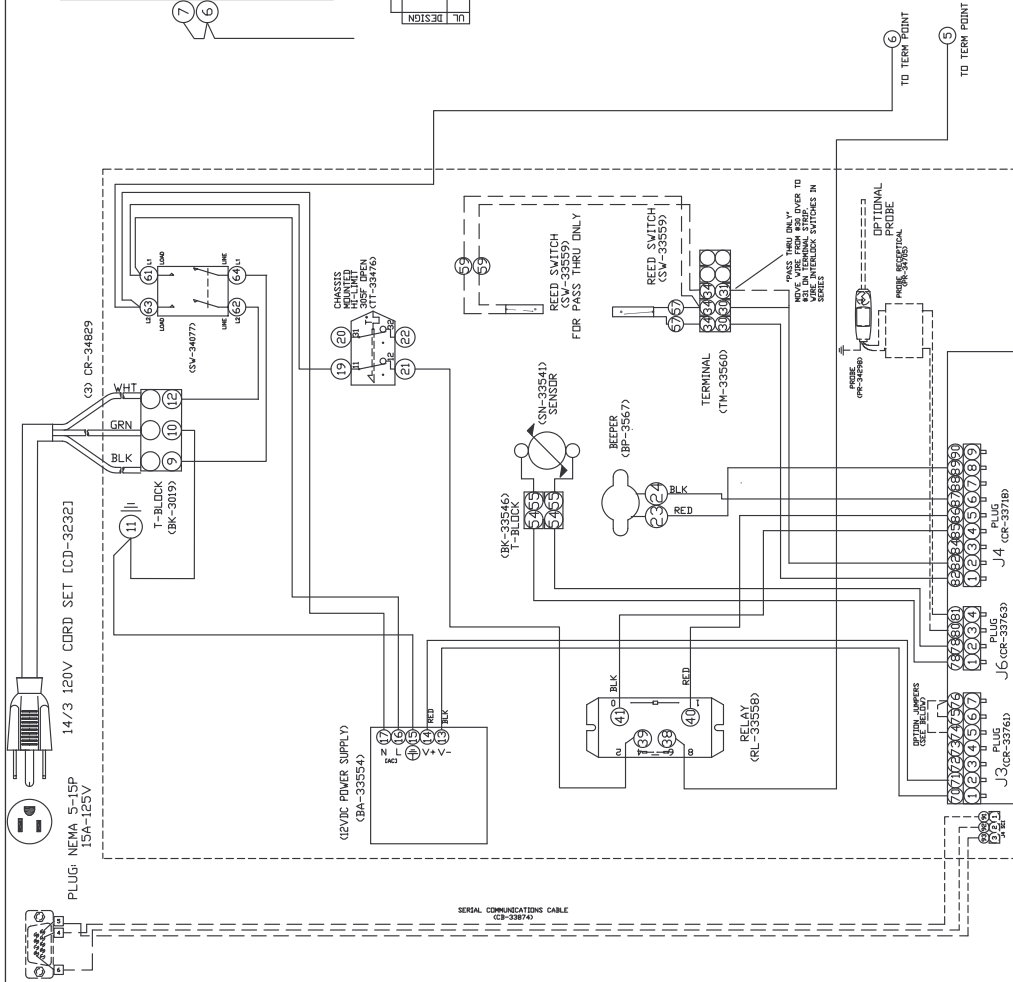

PLUG: NEMA 5-15P 15A-125V
 14/3 120V CORD SET ICD-32321
 (3) CR-348B9
 T-BLOCK (BK-3019)
 (SV-34077)
 CHASSIS MOUNTED 250° OPEN (TT-33476)
 (12VDC POWER SUPPLY) (BA-33554)
 RELAY (RL-3355B)
 REED SWITCH (SN-33541) SENSOR
 REED SWITCH (SV-33559) FOR PASS THRU ONLY
 BEER (BP-3567)
 TERMINAL (TM-33560)
 OPTIONAL PROBE
 SERIAL COMMUNICATIONS CABLE (CS-23874)
 J3 (CR-33763) J4 (CR-33718) J6 (CR-33763)
 TO TERM POINT 6 TO TERM POINT 5
 MOVE WIRE FROM THIS DRIVER TO WIRE IN INTERLOCK SWITCHES IN SERIES

STD CONTROL CS-34225
 STD CONTROL W/HADCP 5008913 (ENABLE PROBE, JUMPER 74-76 ON J3)
 TIMER CONTROL CC-34224 (ENABLE TIMERS, JUMPER 75-76 ON J3)
 TIMER CONTROL W/HADCP 5009526 (ENABLE PROBE, JUMPER 74-76 ON J3), ENABLE TIMERS, JUMPER 75-76 ON J3

11	5904	REDUCE 1200-S WATTS	2-18-11	JPK
10	-	HTG CBL POST CHNG 1000-S	1-4-11	JPK
9	5776	UPDATE PROBE P/N	11-5-10	REJ
REV	ECO	DESCRIPTION	DATE	APP
		500,750,1000,1200-S ELEC 120V 60HZ		

ALTO-SHAAM		WIRING DIAGRAM	
BY: MS	DATE: 02/13/07	DWG: 7862	SHEET 1_DF_1

NOTE #1: ALL NUMBERS IN () = ALTO-SHAAM PART NUMBERS
 NOTE #2: SEE DRW. 5006457 FOR WIRE ASSEMBLIES

TOP VIEW OF CABLE CONFIGURATION

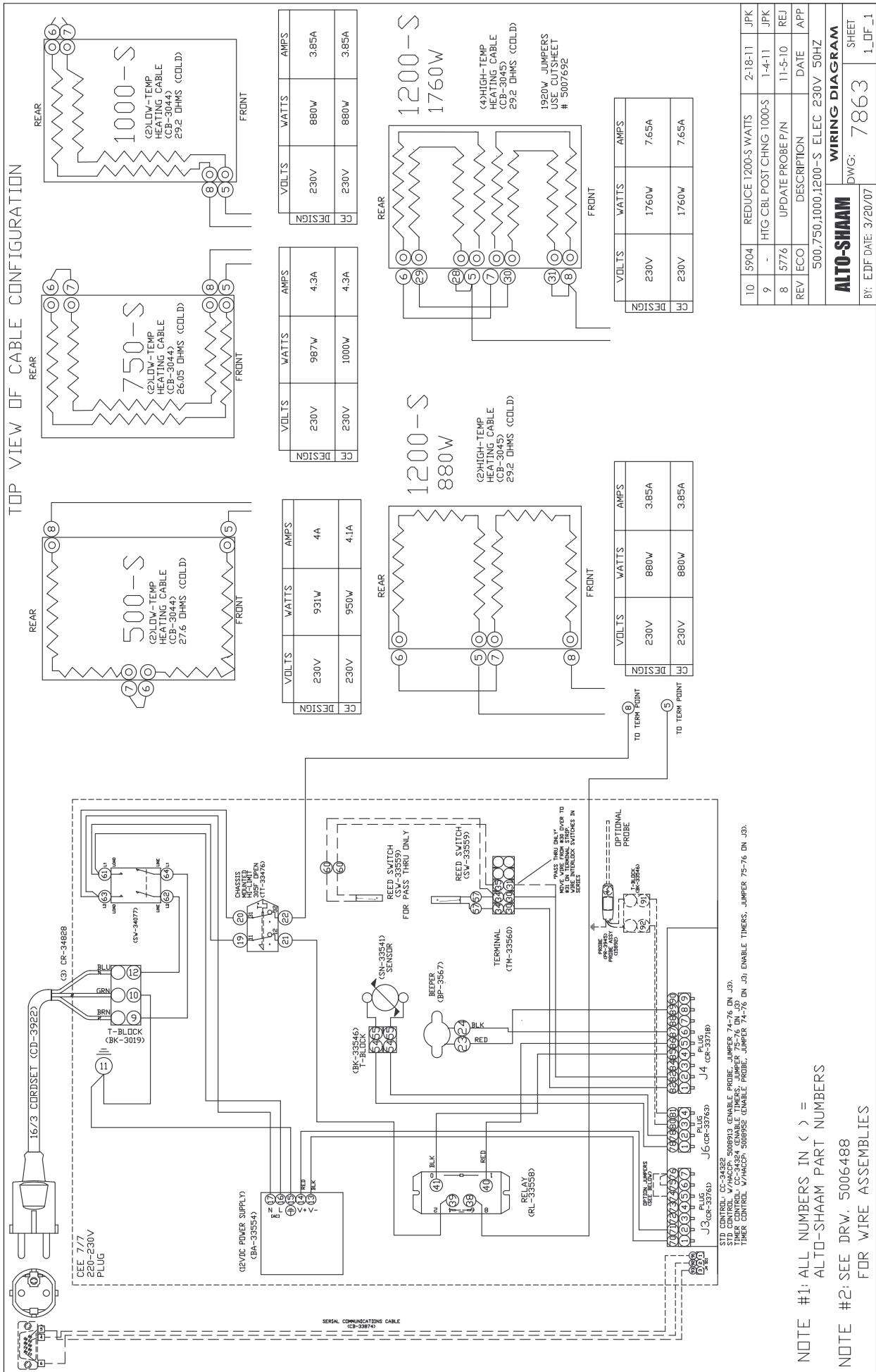

NOTE #1: ALL NUMBERS IN () = ALTO-SHAAM PART NUMBERS FOR WIRE ASSEMBLIES

NOTE #2: SEE DRW. 5006488 FOR WIRE ASSEMBLIES

VIEW FROM REAR OF BONNET

(FRONT)

UPPER CONTROLS

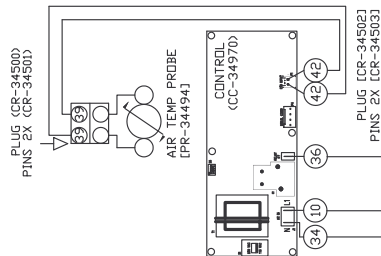

LOWER CONTROLS

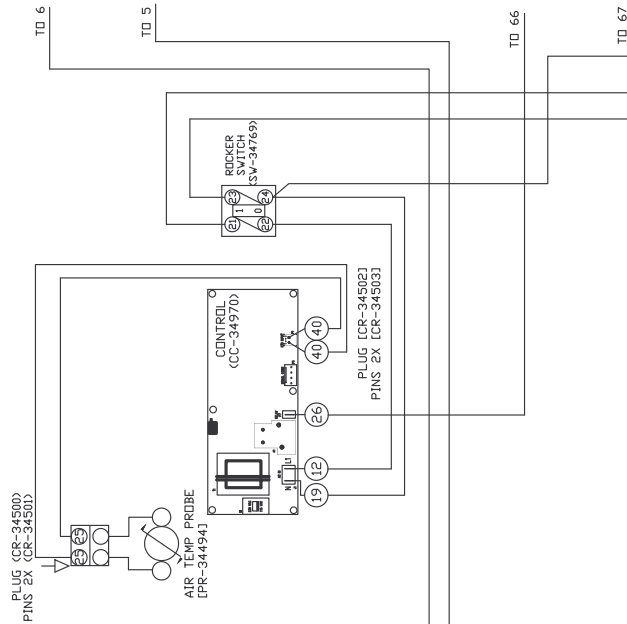

1200-UP UPPER
HI-TEMP
HEATING CABLE
2 LENGTHS OF (CB-3045)
29.2 OHMS EA COLD
30 OHMS EA HOT

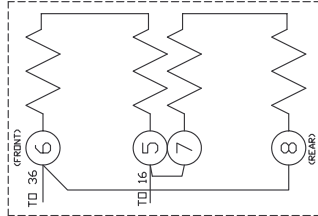

1000-UP UPPER
LOW-TEMP
HEATING CABLE
2 LENGTHS OF (CB-3044)
29.2 OHMS EA COLD
30 OHMS EA HOT

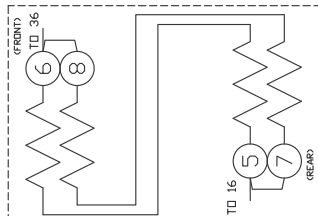

1200-UP LOWER
HI-TEMP
HEATING CABLE
2 LENGTHS OF (CB-3045)
29.2 OHMS EA COLD
30 OHMS EA HOT

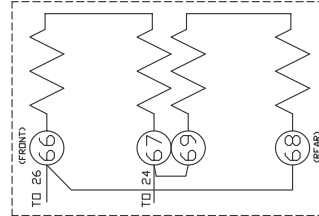

1000-UP LOWER
LOW-TEMP
HEATING CABLE
2 LENGTHS OF (CB-3044)
29.2 OHMS EA COLD
30 OHMS EA HOT

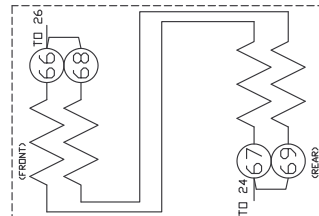

DESIGN	VOLTS	WATTS	AMPS
F	120V	1920W	16A
C	120V	1920W	16A

PLUG, NEMA 5-20P
20 AMP 125 VOLTS

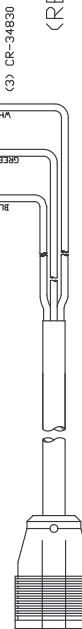

(REAR)

NOTE #1: ALL NUMBERS IN () =
ALTO-SHAM PART NUMBERS

NOTE #2: SEE DRW. 5012823 FOR MAIN WIRE ASSEMBLY
SEE DRW. 5012824 FOR 120V WIRE ASSEMBLY

REV	ECO	DESCRIPTION	DATE	APP
6	5904	REMOVE HTG CABLE LENGTHS	2-18-11	JPK
5	5727	NEW CONTROL	8-25-10	JPK
4	5552	RELEASE TO PRODUCTION	1-11-10	MJP

1000 & 1200-UP/UPS 120V 60HZ

ALTO-SHAM WIRING DIAGRAM

BY: JPK DATE: 1/16/08 DWG: 77190 SHEET 1_DF_1

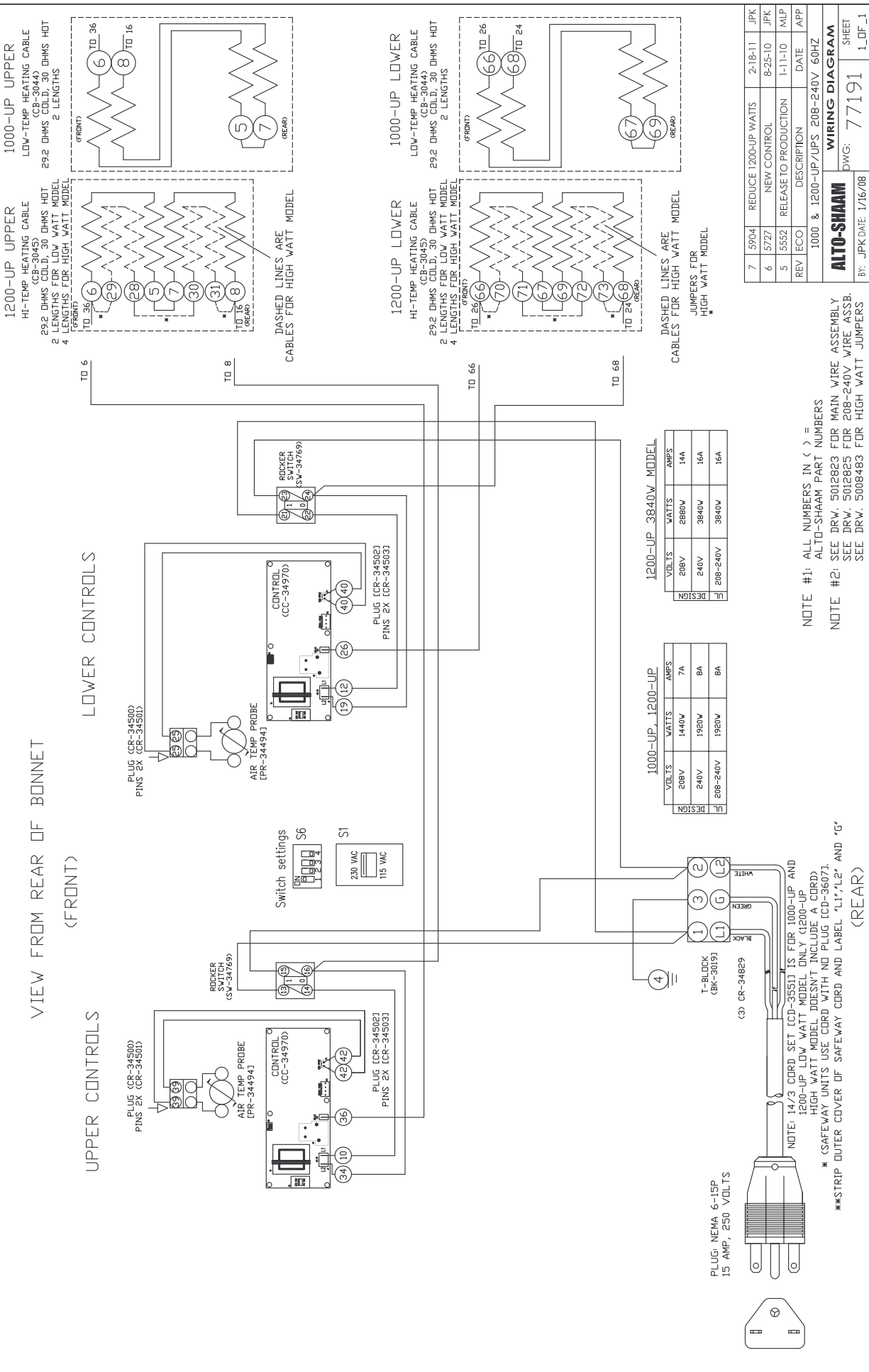

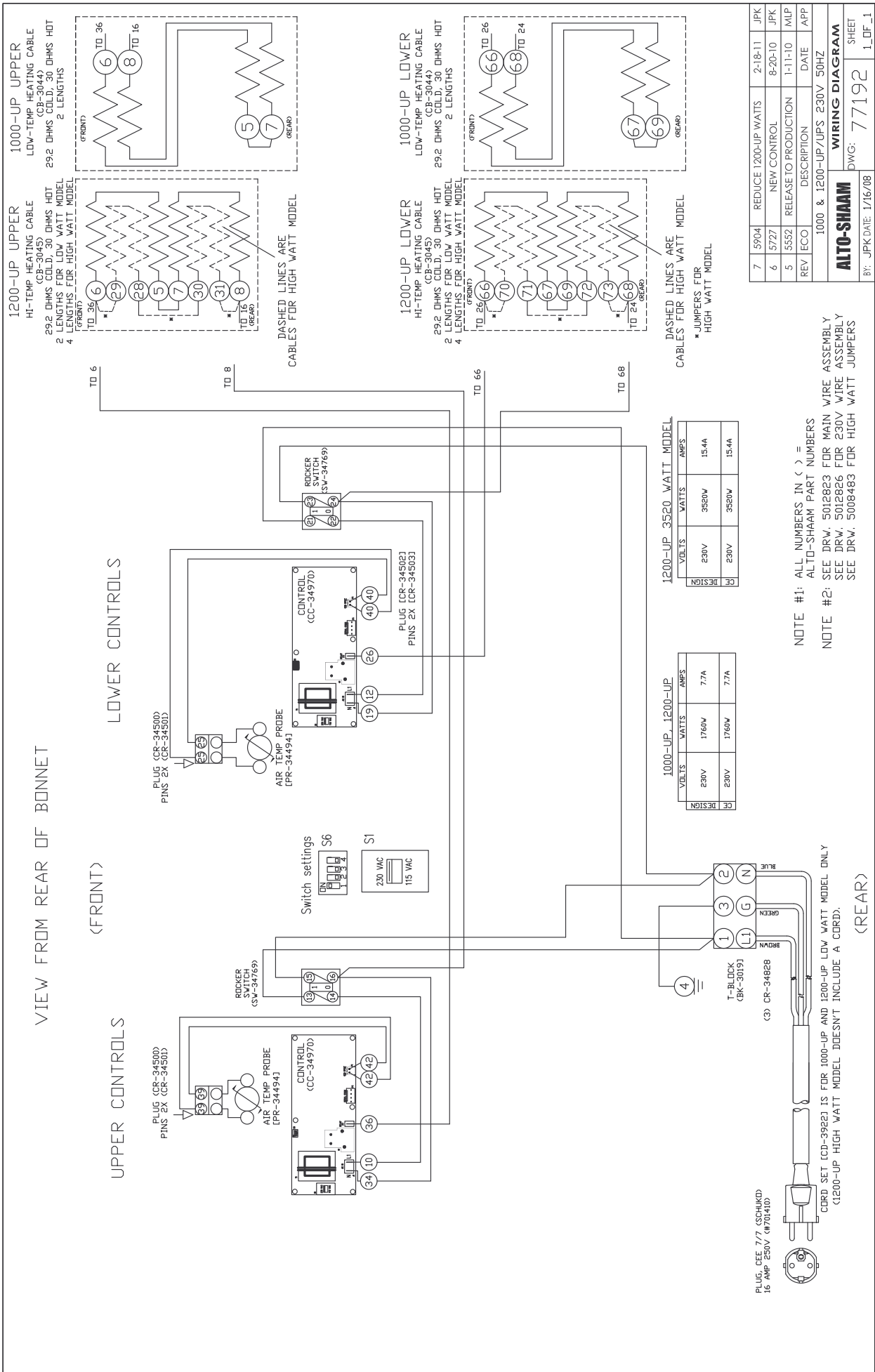

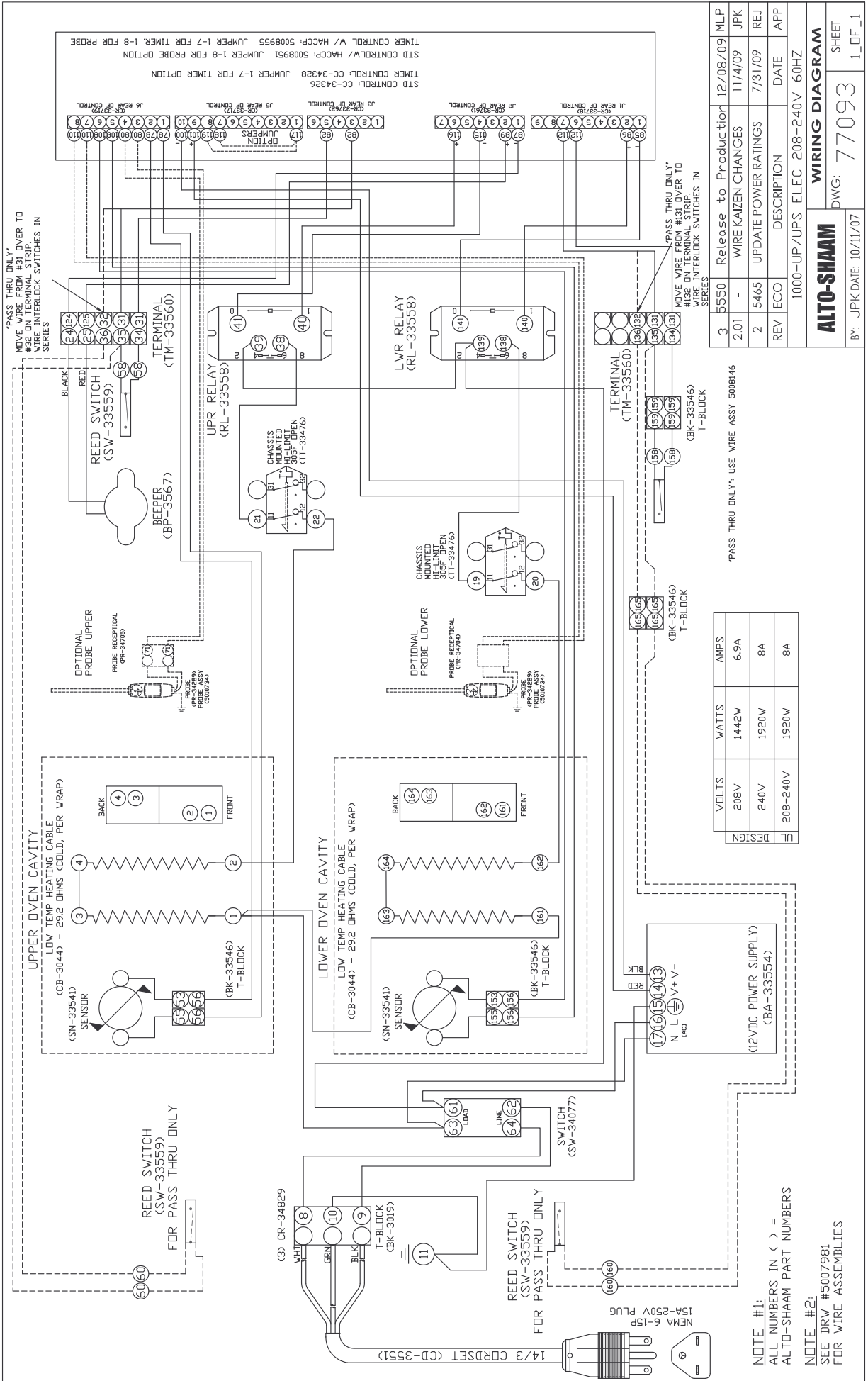

REV	ECO	DESCRIPTION	DATE	APP
3	5550	Release to Production	12/08/09	MLP
2.01	-	WIRE KAIZEN CHANGES	11/14/09	JPK
2	5465	UPDATE POWER RATINGS	7/31/09	REJ

REV	ECO	DESCRIPTION	DATE	APP
1000-UP/UPS	ELEC	208-240V	60HZ	

ALTO-SHAAM	
DWG: 77093	SHEET 1_OF_1

*PASS THRU ONLY: USE WIRE ASSY 500B146

DESIGN	VOLTS	WATTS	AMPS
DESIGN	208V	1442W	6.9A
DESIGN	240V	1920W	8A
DESIGN	208-240V	1920W	8A

NOTE #1:
ALL NUMBERS IN () =
ALTO-SHAAM PART NUMBERS

NOTE #2:
SEE DRW #5007981
FOR WIRE ASSEMBLIES

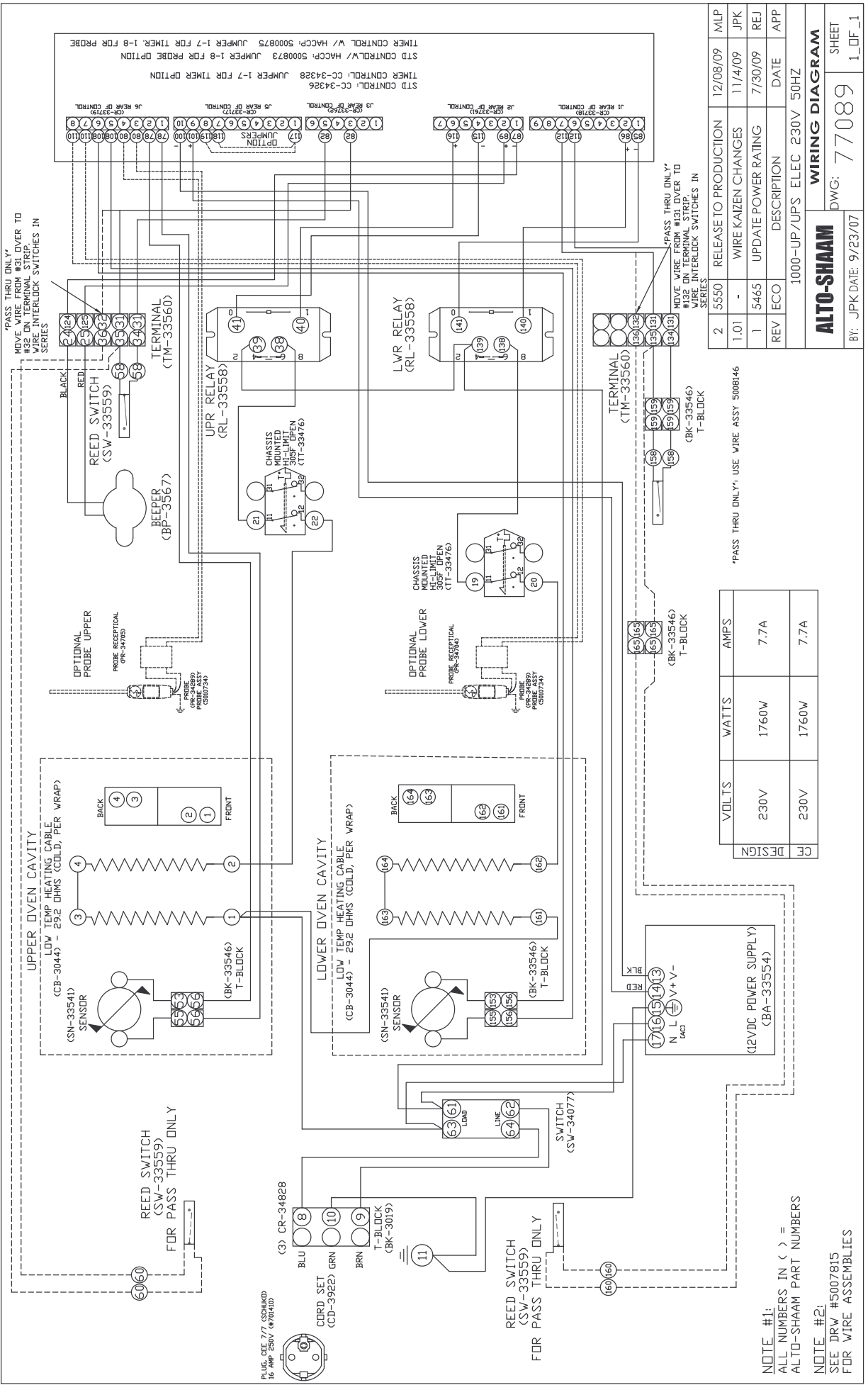

REV	ECO	DESCRIPTION	DATE	APP
2	5550	RELEASE TO PRODUCTION	12/08/09	MLP
1.01	-	WIRE KAIZEN CHANGES	11/14/09	JKP
1	5465	UPDATE POWER RATING	7/30/09	REJ

1000-UP/UPS ELEC 230V 50HZ

VOLTS	WATTS	AMPS
230V	1760W	7.7A
230V	1760W	7.7A

DESIGN	CE
7.7A	7.7A

ALTO-SHAAM
 DWG: 77089
 SHEET 1_OF_1

BY: JPK DATE: 9/23/07

NOTE #1:
 ALL NUMBERS IN () =
 ALTO-SHAAM PART NUMBERS

NOTE #2:
 SEE DRW #5007815
 FOR WIRE ASSEMBLIES

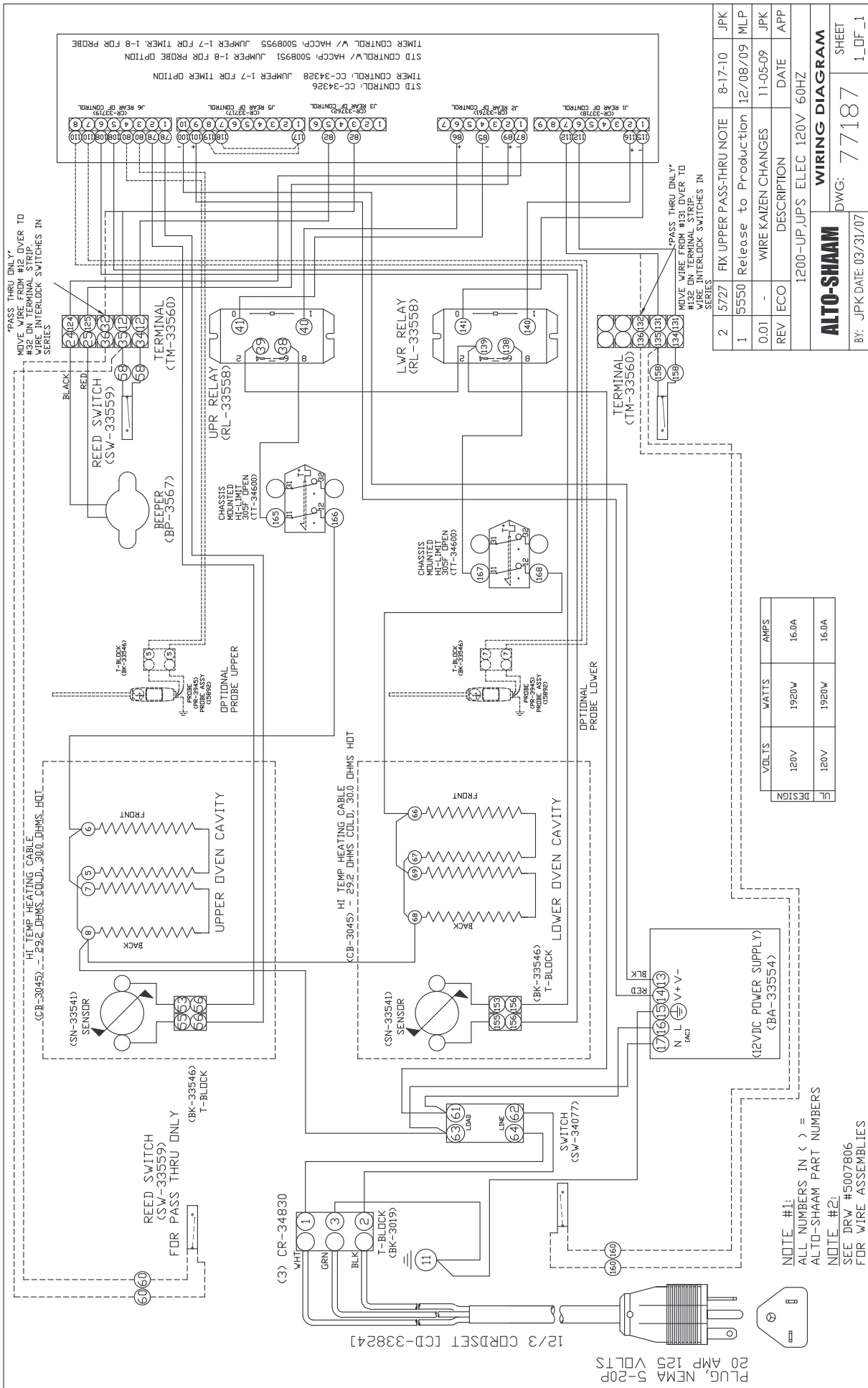

REV	ECO	DESCRIPTION	DATE	APP
2	5727	FIX UPPER PASS-THRU NOTE	8-17-10	JPK
1	5550	Release to Production	12/08/09	MLP
0.01	-	WIRE KAIZEN CHANGES	11-05-09	JPK

1200-UP, UPS ELEC 120V 60HZ

ALTO-SHAAM
DWG: 77187

BY: JPK DATE: 03/31/07

WIRING DIAGRAM
SHEET 1_OF_1

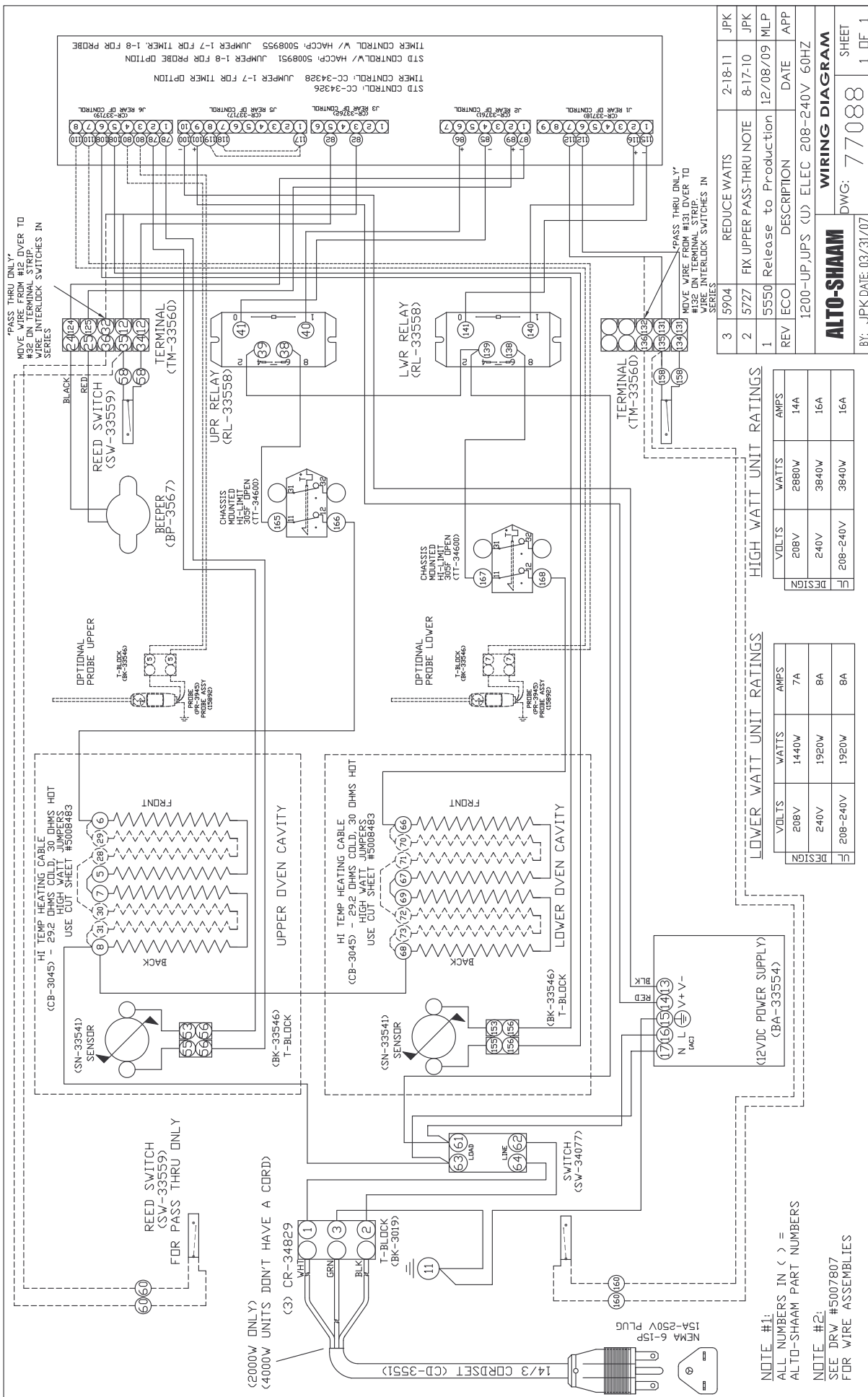

3	5904	REDUCE WATTS	2-18-11	JPK
2	5727	FIX UPPER PASS-THRU NOTE	8-17-10	JPK
1	5550	Release to Production	12/08/09	MLP
REV	ECO	DESCRIPTION	DATE	APP
		1200-UP,UPS (U) ELEC 208-240V 60HZ		

HIGH WATT UNIT RATINGS	
VOLTS	WATTS
DESIGN	208V 2880W
DESIGN	240V 3840W
F	208-240V 3840W

LOWER WATT UNIT RATINGS	
VOLTS	WATTS
DESIGN	208V 1440W
DESIGN	240V 1920W
F	208-240V 1920W

HIGH WATT UNIT RATINGS	
VOLTS	AMPS
DESIGN	14A
DESIGN	16A
F	16A

NOTE #1:
 ALL NUMBERS IN () =
 ALTO-SHAAM PART NUMBERS

NOTE #2:
 SEE DRAW #5007807
 FOR WIRE ASSEMBLIES

ALTO-SHAAM
 DWG: 77088
 BY: JPK DATE: 03/31/07
 SHEET 1_OF_1

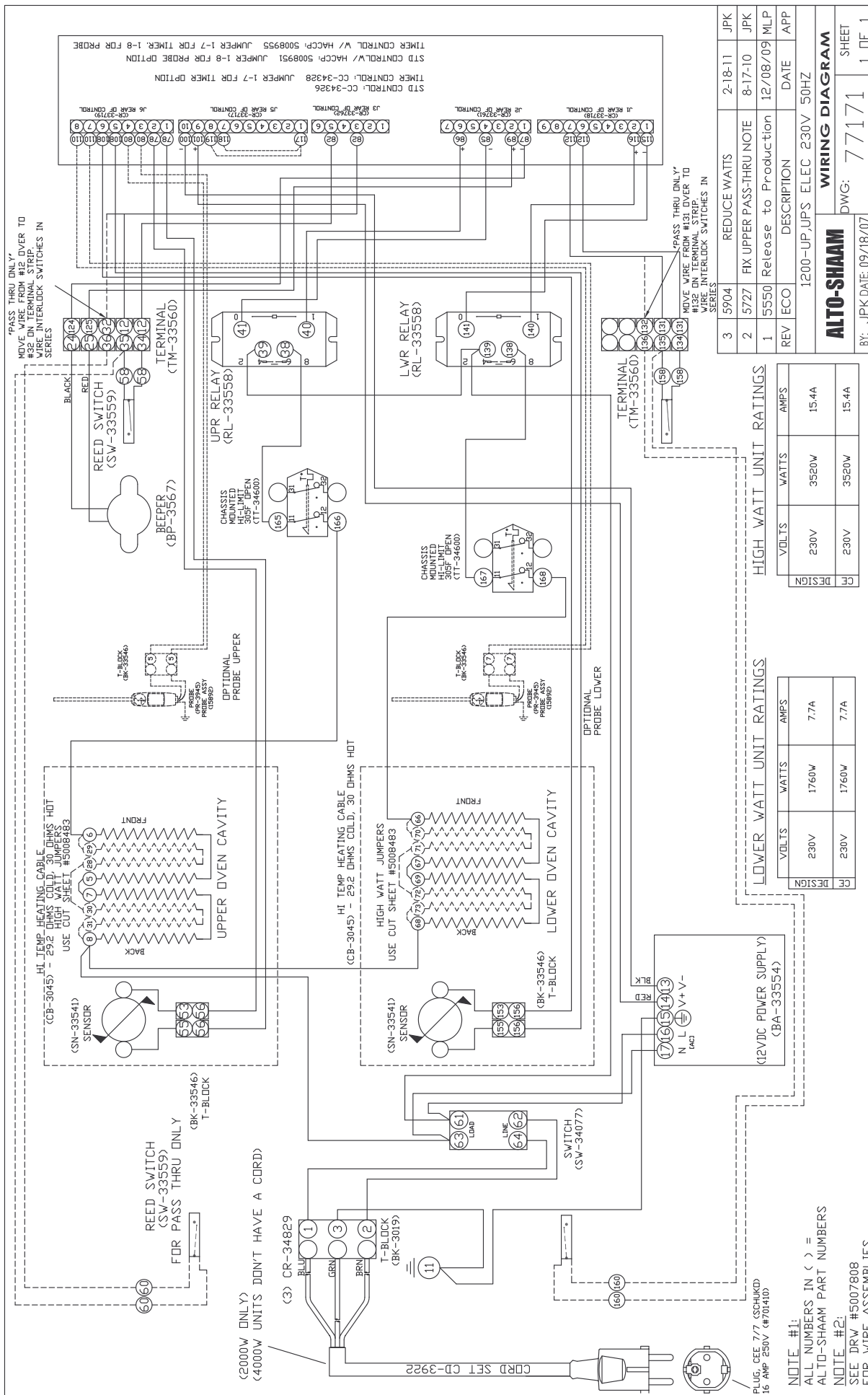

TRANSPORTATION DAMAGE and CLAIMS



All Alto-Shaam equipment is sold F.O.B. shipping point, and when accepted by the carrier, such shipments become the property of the consignee.

Should damage occur in shipment, it is a matter between the carrier and the consignee. In such cases, the carrier is assumed to be responsible for the safe delivery of the merchandise, unless negligence can be established on the part of the shipper.

1. Make an immediate inspection while the equipment is still in the truck or immediately after it is moved to the receiving area. Do not wait until after the material is moved to a storage area.
2. Do not sign a delivery receipt or a freight bill until you have made a proper count and inspection of all merchandise received.
3. Note all damage to packages directly on the carrier's delivery receipt.
4. Make certain the driver signs this receipt. If he refuses to sign, make a notation of this refusal on the receipt.
5. If the driver refuses to allow inspection, write the following on the delivery receipt:
Driver refuses to allow inspection of containers for visible damage.
6. Telephone the carrier's office immediately upon finding damage, and request an inspection. Mail a written confirmation of the time, date, and the person called.
7. Save any packages and packing material for further inspection by the carrier.
8. Promptly file a written claim with the carrier and attach copies of all supporting paperwork.

We will continue our policy of assisting our customers in collecting claims which have been properly filed and actively pursued. We cannot, however, file any damage claims for you, assume the responsibility of any claims, or accept deductions in payment for such claims.

LIMITED WARRANTY

Alto-Shaam, Inc. warrants to the original purchaser only that any original part that is found to be defective in material or workmanship will, at Alto-Shaam's option, subject to provisions hereinafter stated, be replaced with a new or rebuilt part.

The parts warranty period is as follows:

For the refrigeration compressor on Alto-Shaam Quickchillers™, five (5) years from the date of installation.

For the heating element on Halo Heat® cook/hold ovens, as long as the original purchaser owns the oven.

For all other parts, one (1) year from the date of installation or fifteen (15) months from the shipping date, whichever occurs first.

The labor warranty period is one (1) year from the date of installation or fifteen (15) months from the shipping date, whichever occurs first.

Alto-Shaam will bear normal labor charges performed during standard business hours, excluding overtime, holiday rates or any additional fees.

To be valid, a warranty claim must be asserted during the applicable warranty period. This warranty is not transferable.

THIS WARRANTY DOES NOT APPLY TO:

1. Calibration.
2. Replacement of light bulbs, door gaskets, and/or the replacement of glass due to damage of any kind.
3. Equipment damage caused by accident, shipping, improper installation or alteration.
4. Equipment used under conditions of abuse, misuse, carelessness or abnormal conditions, including but not limited to, equipment subjected to harsh or inappropriate chemicals, including but not limited to, compounds containing chloride or quaternary salts, poor water quality, or equipment with missing or altered serial numbers.
5. Damage incurred as a direct result of poor water quality, inadequate maintenance of steam generators and/or surfaces affected by water quality. Water quality and required maintenance of steam generating equipment is the responsibility of the owner/operator.
6. Damage caused by use of any cleaning agent other than Alto-Shaam's Combitherm® Cleaner, including but not limited to damage due to chlorine or other harmful chemicals. **Use of Alto-Shaam's Combitherm® Cleaner on Combitherm® ovens is highly recommended.**
7. Any losses or damage resulting from malfunction, including loss of product or consequential or incidental damages of any kind.
8. Equipment modified in any manner from original model, substitution of parts other than factory authorized parts, removal of any parts including legs, or addition of any parts.

This warranty is exclusive and is in lieu of all other warranties, express or implied, including the implied warranties of merchantability and fitness for a particular purpose. In no event shall Alto-Shaam be liable for loss of use, loss of revenue or profit, or loss of product, or for any indirect, special, incidental, or consequential damages. No person except an officer of Alto-Shaam, Inc. is authorized to modify this warranty or to incur on behalf of Alto-Shaam any other obligation or liability in connection with Alto-Shaam equipment.

Effective 09/10



RECORD THE MODEL AND SERIAL NUMBER OF THE APPLIANCE FOR EASY REFERENCE.

ALWAYS REFER TO BOTH MODEL AND SERIAL NUMBER IN ANY CONTACT WITH ALTO-SHAAM REGARDING THIS APPLIANCE.

Model: _____ Date Installed: _____
Voltage: _____ Purchased From: _____
Serial Number: _____

W164 N9221 Water Street • P.O. Box 450 • Menomonee Falls, Wisconsin 53052-0450 • U.S.A.
PHONE: 262.251.3800 • 800.558-8744 USA/CANADA FAX: 262.251.7067 • 800.329.8744 U.S.A. ONLY

www.alto-shaam.com

PRINTED IN U.S.A.



FOODSERVICE EQUIPMENT SPARES LTD

UNIT 4 SANDBROOK PARK, SANDBROOK WAY, ROCHDALE, OL11 1RY

01706 353 633

SALES@FOODSERVICESPARES.COM



WWW.FOODSERVICESPARES.COM