



TECHNICAL **DIAGRAMS**



CITIZEN 6-9 GAS PW

01706 353 633

WWW.FOODSERVICESPARES.COM



DR. ZANOLLI s.r.l.
Via Casa Quindici, 22
37060 Caselle di Sommacampagna (Verona) Italy
Tel +39 045 8581500 (r.a.)
Fax +39 045 8581455
Web: www.zanolli.it - e-mail: zanolli@zanolli.it

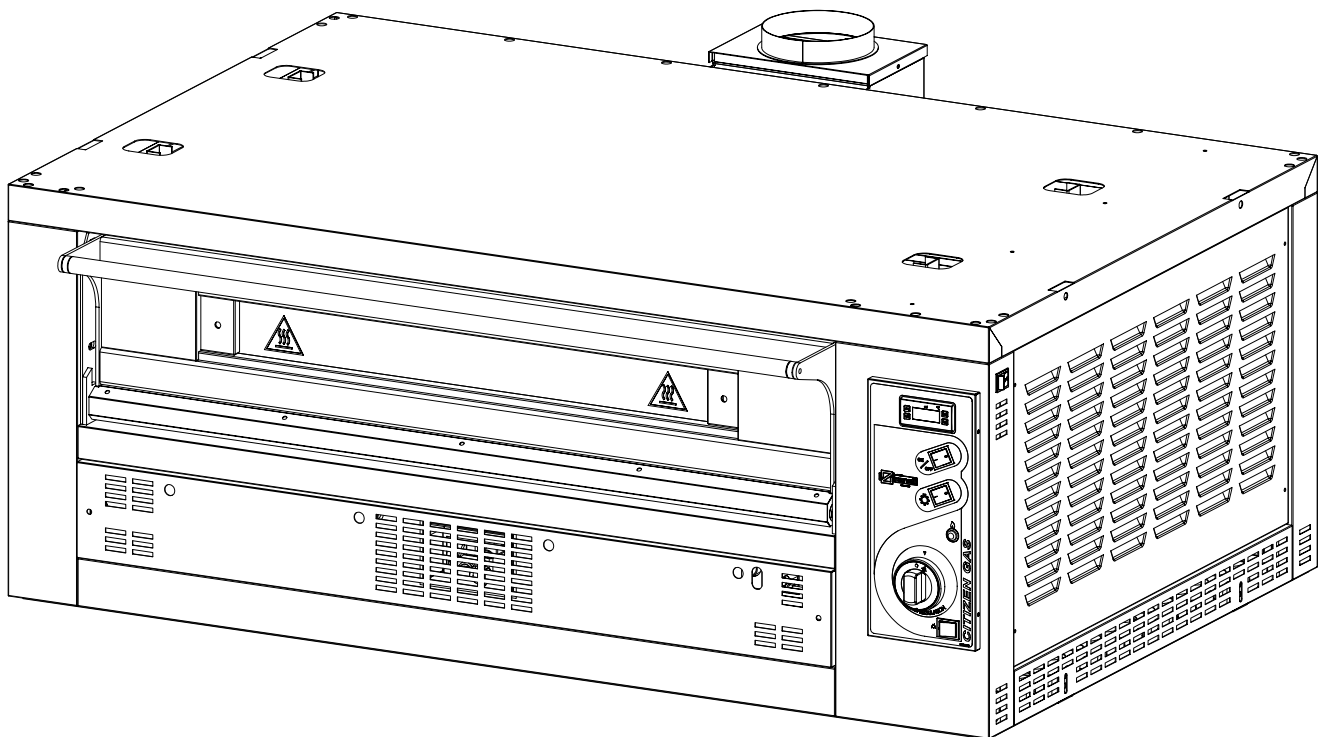

CITIZEN 6-9 GAS PW













Pizza Oven

Manual for installation use and maintenance

dr.Zanoli s.r.l.
via Casa Quindici 22
37060 Caselle di Sommacampagna VR
Tel. +39-0458581500 Fax +39-0458581455
VAT N.IT00213620230

Citizen 6-9 gas PW
English Manual
cod. CITG.G.EM.PW.UK.09
rev. 0.0 del 15/02/11

INDEX

1. INTRODUCTION	5
2. HOW TO USE THIS MANUAL	6
3. SPECIFICATIONS	8
3.1 IDENTIFYING THE PRODUCT	8
THESE INSTRUCTIONS REFER TO THE CITIZEN GAS 6 AND CITIZEN GAS 9 COOKING UNITS.	8
3.2 CONFORMITY TO EUROPEAN DIRECTIVES	8
3.3 INTENDED OPERATING CONDITIONS	8
3.4 TECHNICAL SPECIFICATIONS	8
4. INSTALLATION.....	11
4.1 CHECKING ON DELIVERY	11
4.2 CHOOSING A PLACE FOR INSTALLATION	12
4.3 MANOUVERING THE MODULE	12
4.4 POSITIONING AND MOUNTING THE MODULE.....	13
4.5 CONNECTING THE GAS SUPPLY	13
4.5.1 Gas supply tube.....	13
4.6 ELECTRICAL CONNECTION	14
4.7 CHECKING BEFORE USE.....	16
5. OPERATING THE OVEN	17
5.1 DESCRIPTION OF THE CONTROL PANEL.....	17
Temperature control (vers. TERM0012)	17
Temperature control (vers. TERM0060)	17
5.1.1 DIGITAL THERMO-REGULATOR (VERS. TERM0 012).....	18
 , Set button  ESC button (vers. TERM0012)	18
Buttons  and 	18
out  Out indicator (vers. TERM0012)	19
5.1.2 DIGITAL THERMOREGULATOR (VERS. TERM0060)	19
 SET and ESC buttons (vers. TERM0060).	19
"out1" Green led indicator (vers. TERM0060).....	20
5.1.3   MASTER SWITCH.....	20
5.1.4   LIGHT SWITCH	20
5.1.5  VENTILATION HOOD POWER SWITCH	20
5.1.6  GREEN BURNER ACTIVITY INDICATOR.....	20

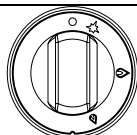

5.1.7 **ON/OFF KNOB FOR PILOT LIGHT AND BURNER** 21

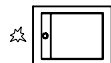

5.1.8 **PILOT LIGHT IGNITION SWITCH** 21

5.2	ERROR INDICATION	22
5.2.1	<i>Disconnected thermocouple (vers. TERM0012)</i>	22
5.2.2	<i>Disconnected thermocouple (vers. TERM0060)</i>	22
5.3	LACK OF GAS OR ELECTRICITY SUPPLY	22
6.	USE	23
6.1	TURNING ON FOR THE FIRST TIME	23
6.2	PILOT LIGHT FAILS TO TURN ON	24
6.3	RAISING AND LOWERING THE TEMPERATURE	24
6.4	HOW TO TURN OFF THE OVEN	25
6.5	GENERAL GUIDELINES FOR COOKING	25
6.6	WHEN THE OVEN IS UNDERUSED	26
7.	CLEANING	27
7.1	CLEANING THE REMOVEABLE PARTS	27
7.2	CLEANING THE PARTS MADE FROM CERAMIC REFRACTORY MATERIAL	27
7.3	CLEANING THE OVEN'S COOKING CHAMBER	28
7.4	CLEANING EXTERNAL SURFACES	28
8.	MAINTAINANCE	29
8.1	CHANGING THE HALOGEN LAMP	29
8.2	SAFETY THERMOSTAT	30
8.3	WIRING DIAGRAM	30
8.4	ADAPTATION TO VARIOUS TYPES OF GAS	32
8.4.1	<i>Substituting the burner/pilot jet</i>	32
8.4.2	<i>Applying the new label</i>	36
8.5	REPLACING THE BURNER JET	36
8.6	EXPLODED DIAGRAMS AND LIST OF REPLACEMENT PARTS	38
9.	DECOMMISSIONING AND DEMOLITION	44
10.	DECLARATION OF CONFORMITY	45

1. INTRODUCTION

The gas fired cooking units for the CITIZEN oven series have been primarily designed for cooking pizzas and similar products in the traditional way.

As part of the modular CITIZEN system they can be coupled together with other elements in the series (hood, baking chamber, basic unit) serving client's specific requirements. The modules are currently available in 2 versions with cooking surfaces for 6 or for 9 pizzas of Ø30 cm.

CITIZEN gas fired cooking modules solve problems for users in areas where a high voltage electricity supply is not readily available. Running the oven on gas also ensures a substantial reduction in running costs, in some cases as low as 60% of those incurred with an equivalent electric oven.

The oven's constructor thanks you for the preference expressed in purchasing this product. We can confidently assure you that it is a good choice. Our company has been committed to the manufacture of quality products for many years. We do not believe in making compromises and use the best possible materials.

2. HOW TO USE THIS MANUAL



The paragraphs marked with this symbol contain indications essential to safety, operating instructions and maintenance. They must all be read both by installers, the end user and any employees that use the oven. The manufacturer does not assume any responsibility for damage or injury incurring as a result of ignoring the safety criteria outlined in these paragraphs.



This symbol applied to various points on the oven serves to warn the user of danger: “ATTENTION HOT SURFACES”.



This symbol, applied to various points on the oven, serves to warn the user of the presence of a non-insulated “high voltage hazard” inside the oven’s casing there being enough power to constitute a fire risk or to electrocute a person.



The paragraphs marked with this symbol contain important information to avoid causing damage to the oven. It is in the users own interests to read these paragraphs carefully.



It is recommended that this installation, instruction and service manual be kept in close proximity to the equipment so that it can be easily and quickly consulted. The manual must accompany the equipment if it is resold as it cannot be considered complete and safe without it.

Take note of the code shown on the back cover. In the event that this copy is lost or destroyed, you can order another copy using the details [mentioned later in the manual. It would be a good idea to write this code down on a separate piece of paper.



This manual is made up of a number of chapters. They should be read in their entirety by both installers and service personnel as well as by the end user to ensure getting the best results from this product.

Nevertheless, a rapid consultation of the various chapters may sometimes be necessary and to facilitate this, a brief summary of their contents is given below.

Chapter 3 contains the specifications of the oven and all the values that are necessary for choosing the right environment for its installation and use.

This manual should be used as a point of reference to check that the equipment is being used in the way intended and ensure that information concerning the precise value of a given measurement or tolerance of the equipment is available whenever necessary.

Chapter 4 contains all the information needed to install the oven. These are mainly aimed at specialized personnel but should be read by the end user beforehand so as to predispose the environment where the oven will be operated for installation.

Chapters 5 and 6 serve as a guide to the user in the essential operations of turning on, using and turning off the oven under safe conditions.

Chapter 7 supplies all the information necessary for the cleaning of the equipment: all those operations that must be carried out by the user to guarantee that the equipment continues to function under safe conditions (above all those concerning hygiene) and continues to give the best results.

Chapter 8 supplies the information needed for the periodic operations of maintenance and extraordinary interventions such as repairs or changing parts of the equipment. This chapter also shows an exploded diagram of the appliance and a list of spare parts to help in ordering and substituting them if they are damaged.

 These maintenance operations must be carried out by specialized personnel.

Chapter 9 offers information in the event that the oven is no longer used for a prolonged period.

Charter 10 facsimile declaration of conformity.

3. SPECIFICATIONS

3.1 IDENTIFYING THE PRODUCT

These instructions refer to the Citizen gas 6 and Citizen gas 9 cooking units.

3.2 CONFORMITY TO EUROPEAN DIRECTIVES

Both the Citizen gas 6 and Citizen gas 9 cooking units bear the following obligatory markings

CE showing their conformity to the following European directives

2004/108/CE electromagnetic compatibility;
2006/95/CE low voltage;
2009/142/CE gas appliances.

3.3 INTENDED OPERATING CONDITIONS

Citizen gas 6 and Citizen gas 9 cooking units have been designed for baking pizza, or similar products. The cooking units for the CITIZEN oven series are designed for the catering industry (restaurants, pizza houses, etc..) for professional use by trained personnel.

The operations intended to be carried out with the units are: the loading and unloading of products from the baking chamber, turning on, regulating and turning off the oven and cleaning of the entire piece of equipment.

3.4 TECHNICAL SPECIFICATIONS

The following table shows the cooking units' technical specifications.

	Citizen 6 GAS	Citizen 9 GAS	Unità di misura
Weight	250	328	Kg
External dimensions	1450x1090x560	1450x1440x560	mm
Chamber dimensions	1050x700x160	1050x1050x160	mm
Hourly Production	13.5 (n°45 pizze/h da 300 gr.)	16 (n°54 pizze/h da 300 gr.)	Kg/h
Electricity supply	Single phase		
Voltage	230		Vac
Frequency	50 o 60		Hz
Current at 230 V 50 Hz	2	2	A
Total electrical power	100	100	W
Electric connection	Tripolar cable without plug		
Length of cable	2		m
Duct diameter	1.5		mm ²
Chamber illumination light			
Type	HALOGEN		
Power	50		W
Burner type	Atmosferico/Atrmospheric		
Category	AT II _{2H3B/P-} DK SE FI CH II _{2H3B/P-} CH ES GB IE IT PT II _{2H3+} - LU I _{2E-} DE II _{2ELL3B/P-} GR BE I ₃₊ FR BE II _{2E+3+} - NO I _{3B/P-} NL II _{2L3B/P-}		
Gas connection	ISO 7 - (Conic gas thread)		
Øtube	1/2"		
Consumption			
Burner power maximum	13	20	kW
Capacity G20	1.376	2.116	m ³ /h
Capacity G25	1.600	2.462	m ³ /h
Capacity G30	1.025	1.577	Kg/h
Capacity G31	1.010	1.554	Kg/h
Burner power minimum	8	13	kW
Fume outlet			
Type	A1		
Diameter	150		mm
Air Exchange			
	34		m ³ /h
Flame control	Electronic regulation with pilot light		
Safety time	<30		s
Flame ignition	by spark		
Baking control	computerised electronics		
Unit of temperature	°C		

SPECIFICATIONS

measurement		
Maximum temperature setting	370	°C
Flame intensity regulation	-	
Error indication	in display	
Ambient conditions		
Temperature	0 - 40	°C
Maximum humidity	95% without condensation	

Predisposed for	G20	20 mbar
------------------------	------------	----------------

Table 3-1 Technical specifications

4. INSTALLATION

 **ATTENTION:** these installation instructions are for the exclusive use of personnel qualified for the installation and maintenance of gas appliances. An installation carried out by unqualified persons could cause damage to the oven, to people, animals or property.

 **ATTENTION:** Proceed with the installation according to those norms in force in the country in which it is carried out.

In addition, where it is necessary to carry out modifications or adaptations to the electrical or gas systems of the building in which the oven will be installed, whoever carries out such modifications must certify that the work has been undertaken according to current “best practices”

4.1 CHECKING ON DELIVERY

Unless otherwise agreed, the products are carefully packaged with a robust structure in wood and with a sheet of nylon bubble wrap giving protection against knocks and humidity during transport. These are consigned to the freight operator in the best of condition.

We therefore advise you to check the packaging on arrival for any signs of damage. If damage has occurred, have it noted on the receipt which must be signed by the driver.

Once the equipment has been unpacked, check that it has suffered damage. Also check that all the disassembled parts are present. In the event of damage to the equipment and/or missing parts, bear in mind that the freight operator only accepts claims within 15 days of delivery and that the manufacturer cannot be held responsible for damage incurred to its products during their delivery. We are however, available to assist you in presenting your claim.

 In the event of damage do not try to use the equipment and consult with professionally qualified personnel.

4.2 CHOOSING A PLACE FOR INSTALLATION

An effective, safe and long lasting functioning of the appliance also depends on the position in which it is installed. For this reason, it is advisable to carefully consider where to install the equipment before it is delivered

Install the appliance in a dry and easily accessible place both to facilitate its use and to carry out cleaning and maintenance. The area around the equipment must be kept clear. It is particularly important to avoid obstructing the cooling outlets and the inlets for taking in air as a combusive agent.

The appliance must be installed at least 20cm from the walls of the room or from other equipment

 Being a gas appliance, the room where it is installed must be sufficiently ventilated

Indicatively there should be an aperture directly connected outdoors at floor level having an area of at least 6cm^2 for every kW of maximum power produced by the burner with a minimum area of 100 cm^2

 It must be ensured that the temperature and humidity levels in the room where the equipment is installed never exceed (not even when the equipment itself or other equipment in the same room is functioning) the maximum and minimum values indicated in the specifications, (refer to paragraph 3.5. Exceeding the maximum temperature or the maximum relative humidity can easily and unexpectedly damage the electrical systems causing a hazardous situation.

4.3 MANOUVERING THE MODULE

To upload and transport the unit while it is packed, a pallet truck or a transpallet lifter with a load capacity at least equal to that of the unit should be used, inserting the forks in the spaces provided at the base of the packing.

To transport the module without packing, use ropes or straps (certified as suitable for lifting heavy loads)

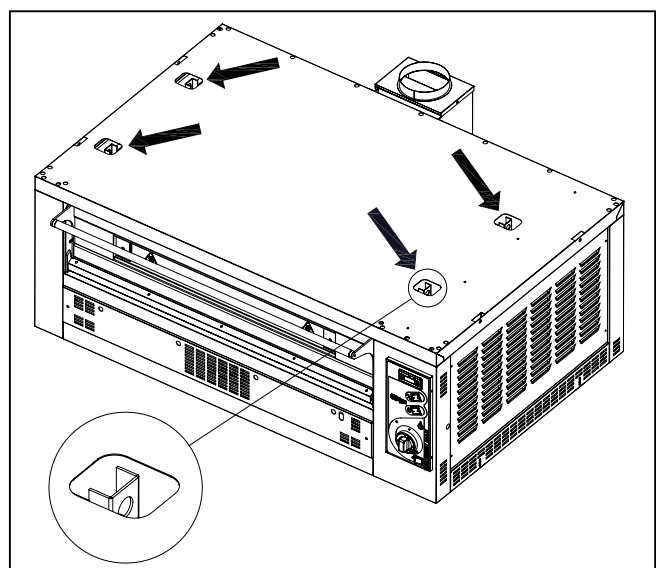

threaded through the rings on the top of the oven and lift with a fork lift truck (Fig.1).

⊘ DO NOT raise the module by inserting forks or bars inside the cooking chamber because this could cause damage the refractory material at the top of the oven

4.4 POSITIONING AND MOUNTING THE MODULE

1 - Position the module on the base /cell/other module, proceeding as described at paragraph 4.3 (Fig.2)

2 - Allow the four fixing Flanges on the corners of the oven to drop into position

3 - Secure with the M5 screws provided

⚠ MAXIMUM NUMBER OF 2 OVENS ONE ON TOP OF THE OTHER

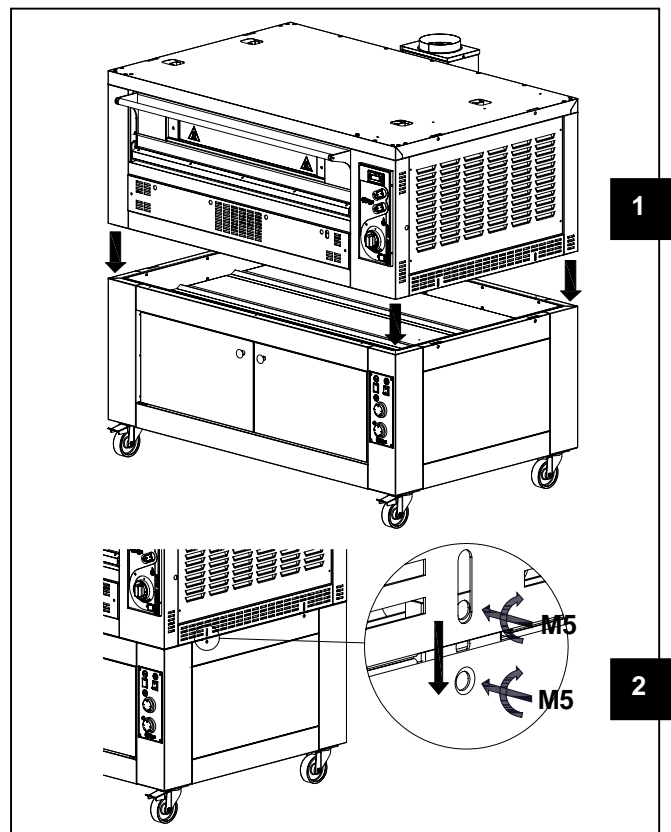

4.5 CONNECTING THE GAS SUPPLY

⚠ Before making any type of connection, ensure that the type of gas and pressure for which the equipment has been calibrated corresponds to the type and the pressure of the gas that is available. This is indicated on the initial regulation label applied to the identification plate. Should these not correspond, refer to paragraph 8.4 to change the regulation.

4.5.1 Gas supply tube

⚠ These gas appliances have a gas input with a 1/2" conic thread as indicated in the specifications. The connection to the building's gas supply must be made by means of metallic tubing in zinc plated steel or in copper. The equipment must be connected to the gas mains supply with an easily operated mains tap.

The connection of the tubing to the equipment must be made with a three piece metal joint to facilitate disassembly

The strength of the gas tight holding on the threaded joint must be ensured with materials specifically declared to be suitable by their manufacturer also for GPL gasses.

For the location of the gas input connections, see Fig. 4-1.

4.6 ELECTRICAL CONNECTION

 The appliances are supplied with an electric connection with ground/earth cable in compliance with the norms in force. **It is obligatory to connect the ground/earth cable (yellow-green) to an earthing system with the same dispersion capacity as the appliance itself. The efficiency of this system must be correctly verified according to the norms in force.**

 Before making any connection check that the specifications of the electrical supply to which the equipment must be connected, correspond to the specifications of the power supply required by the apparatus itself.

In the case of gas equipment without a pilot light, when the 230 Vac needed for supplying power to the control mechanism is obtained with a connection between phase and neutral 400 Vac three phase supply, it is necessary to respect the direction in which the conductors are connected, bearing in mind that the blue conductor should be connected to neutral and the brown connector to the phase. If the direction of connection is not respected, the flame detector will not work with a consequent shutdown of the burner.

The power cable must terminate with a plug to connect to the switchgear having a corresponding differential magneto thermal switch.

The coupling between plug and socket must be such that the earth conductor is connected first and disconnected last and must have the right dimensions for the rated current (see Table 3-1). Plugs and sockets for industrial use of the type CEE17 are suitable or those which satisfy European norm EN 60309

The thermal circuit breaker must be calibrated to the total rated current and the magnetic circuit breaker calibrated to the rated current (In the case of ovens it is only slightly higher than rated current, with machines it is the peak current of the most powerful motor), while the differential mechanism must be calibrated to the 30 mA current (see Table 3-1).

For the positions of the electrical input connectors, see Fig. 4-1

 The manufacturer does not accept responsibility for damage caused by failure to observe the abovementioned norms.

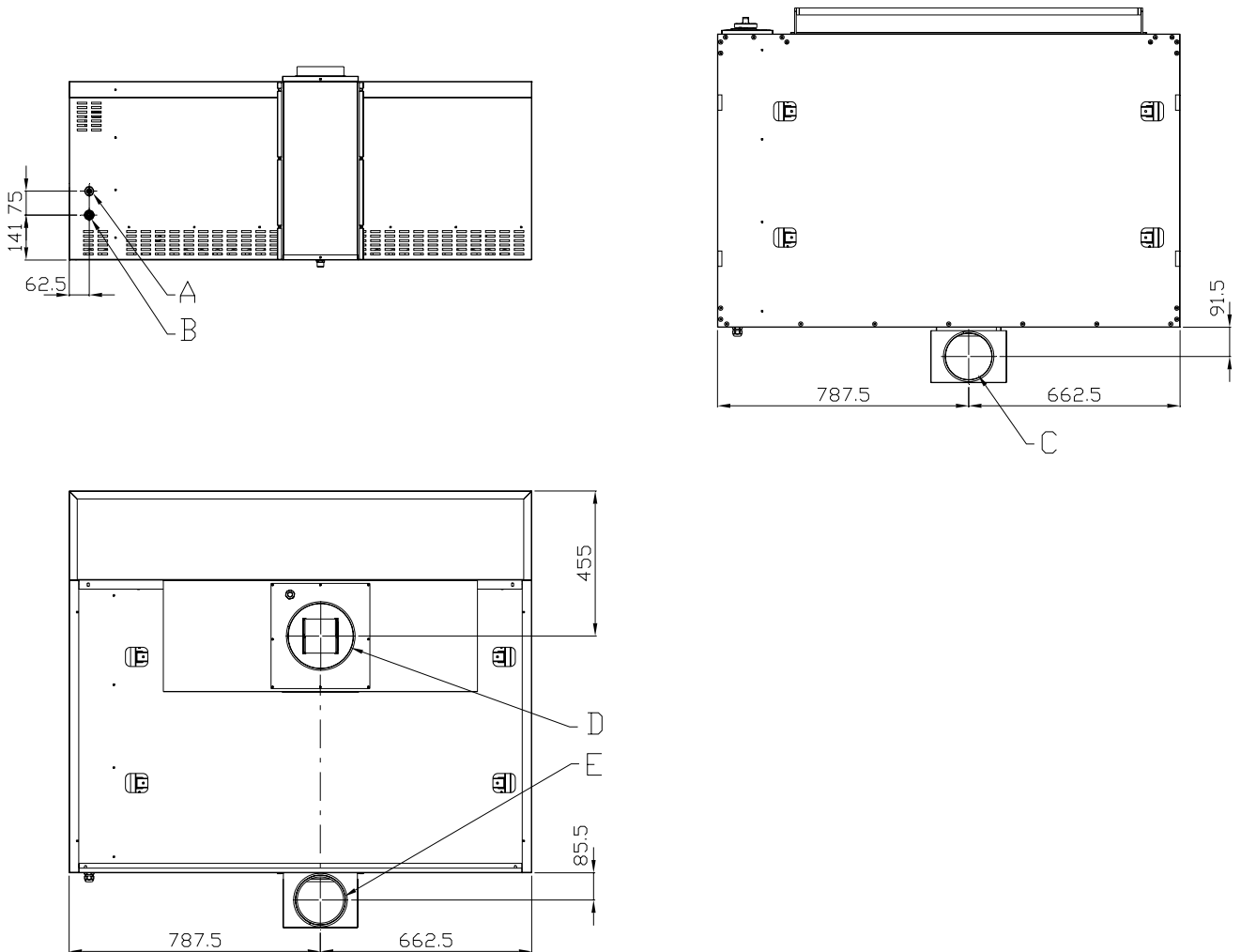

- A= ELECTRICAL POWER INPUT
- B= GAS SUPPLY INPUT
- C= EXHAUST COMBUSTION FUMES Ø 150mm (MODULE WITHOUT HOOD)
- D= VAPOUR EXHAUST Ø 200mm
- E= EXHAUST COMBUSTION FUMES Ø 150mm (MODULE WITH HOOD)

Fig. 4-1 Electrical power connection, gas supply and combustion vapour/fumes exhaust

4.7 CHECKING BEFORE USE

- 1 - Check the electrical cabling
- 2 - Check the gastight integrity of tubing for the gas supply and other tubing for the exhaust gasses
- 3 - Check that the control panel is in working order
- 4 - Check the rated current of the working oven at the solenoid valve termination

5. OPERATING THE OVEN

5.1 DESCRIPTION OF THE CONTROL PANEL

Temperature control (vers. TERM0012)

 Chamber temperature Display

 Set button

 ESC button

 Up button

 Down button

 Out indicator

Temperature control (vers. TERM0060)

 Chamber temperature display

 Set and ESC button

 Up Button

 Down button

"out1" Green led indicator light
"out1"

 Luminous green general master switch

 Luminous yellow on/off light switch

 Command switch for extraction hood

 Green burner functioning indicator

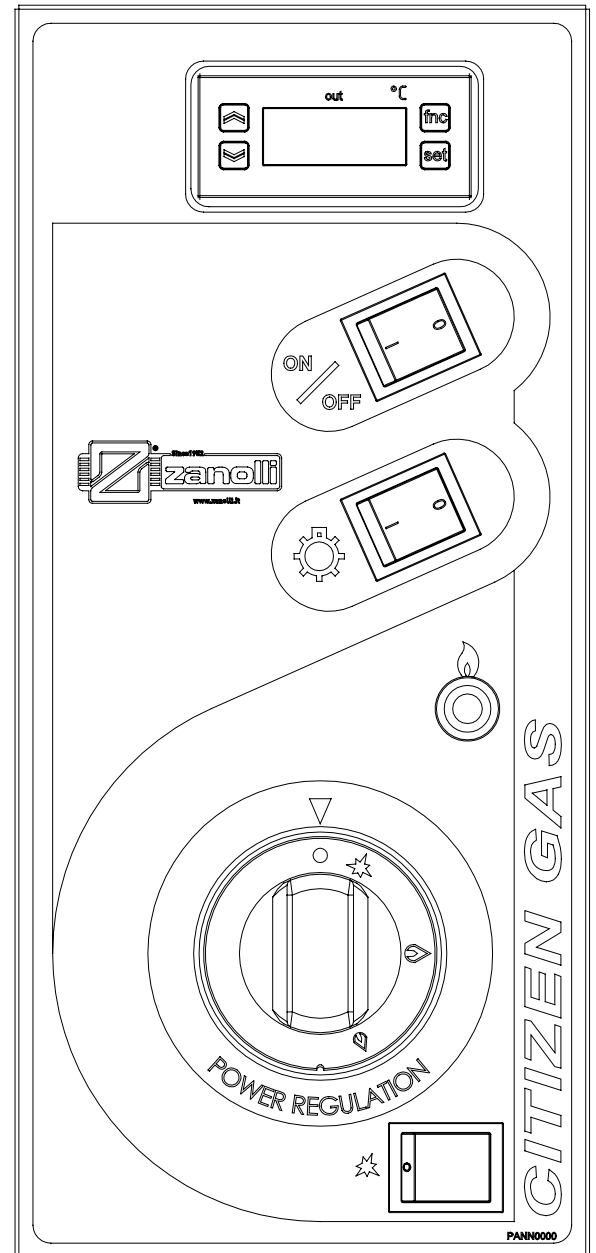
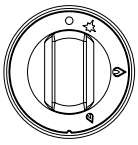
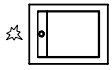

Figure 5-1 shows the control panel with all its control mechanisms



Ignition/out knob for pilot light and burner



Luminous red button for igniting pilot light

5.1.1 DIGITAL THERMO-REGULATOR (VERS. TERM0 012)

In temperature programming mode, this display shows the programmed temperature. The light next to it goes off signaling that the temperature has been reached. This display is also used for indicating some errors.







Set button



ESC button (vers. TERM0012)

Press the  button twice to enter into temperature programming mode.

 **ATTENTION!** Do not keep this button pressed for more than 4 seconds because this accesses the programming of the digital thermo regulator's internal parameters which could be modified causing unpredictable malfunctions.

In this mode the display  shows the programmed temperature that can be varied using the  and  buttons. If no button is pressed for more than 3 seconds, the digital thermo-regulator automatically goes back to its normal mode of functioning.

Press this button  twice to exit from the temperature programming mode.

On the digital thermo-regulator panel there are a display, two buttons and a red Led.

Buttons  **and** 

By pressing and releasing these buttons one press at a time, the temperature setting increases or decreases by one unit. Keeping them pressed progressively increases or decreases the temperature, at first slowly, then with increasing speed.

out **Out indicator (vers. TERM0012)**

The out  indicator illuminates whenever the temperature of the chamber is lower than that set. It goes out when the temperature of the chamber reaches that set and it turns on again when the temperature of the chamber falls by 1 °C below the set temperature.

When the out  indicator lights up, the burner is ignited



5.1.2 DIGITAL THERMOREGULATOR (VERS. TERM0060)

In temperature programming mode, this display shows the programmed temperature. When the indicator light next to it goes out, this signals that the temperature has been reached. This display is used to give some error indications.

set **SET and ESC buttons (vers. TERM0060).**

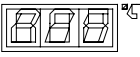

Press the  button once to enter the temperature programming mode

 **ATTENTION!** Do not keep this button pressed because doing so accesses the programming of the digital thermo-regulator's internal parameters which could be modified causing unpredictable malfunctions



In this mode the display  shows the programmed temperature that can be varied using the  and  buttons. If no button is pressed for more than 15 seconds, the digital thermo-regulator automatically goes back to normal functioning mode

Press this button  a second time to exit from the temperature programming mode.

Buttons and

These two buttons increase  and decrease  are for setting the desired temperature which can be carried out at any time. With a brief press on one of the buttons the temperature setting is raised and lowered by 1 °C. Keeping them pressed progressively increases or decreases the temperature, at first slowly, then with increasing speed.

"out1" Green led indicator (vers. TERM0060)

The green led  indicator illuminates whenever the temperature of the chamber is lower than that set. It goes out when the temperature of the chamber reaches that set and it turns on again when the temperature of the chamber falls by 1 °C below the set temperature. The led  indicator flashes when in the programming mode.

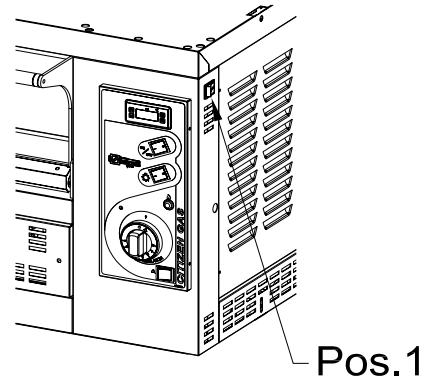



Fig 5-2

When the  indicator lights up, the burner is ignited.

5.1.3 MASTER SWITCH

When this switch is positioned to "0" all the control panel indicators are off. When in the "I" position, the digital thermo-regulator and the switch itself turn on so it is possible to program the temperature and go on to lighting the burner.

N.B.: Switching to "0" when the oven is lit, cuts power to the switchgear, the burner goes out but the pilot light stays alight.

5.1.4 LIGHT SWITCH

When in the "0" position the light is off, when in the "I" position, the light is on.

5.1.5 VENTILATION HOOD POWER SWITCH

Putting the switch mounted on the upper part to one side of the control panel in the "I" position (see Fig. 5-2 Pos.1), starts one of the two intake motors. Putting the switch in the "II" position starts both of the intake motors. Putting the switch in the "0" position shuts down the motors.

5.1.6 GREEN BURNER ACTIVITY INDICATOR

The green indicator lights up to show the burner's effective state of being ignited or extinguished.

When the indicator is on, the burner is lit, when off the burner is off

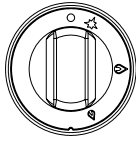

5.1.7 **ON/OFF KNOB FOR PILOT LIGHT AND BURNER**

This knob is for igniting the pilot light and the burner.

To open the flow of gas for the ignition of the pilot light, keep the knob pressed in and turn it anticlockwise until the first step.

To bring the intensity of the burner flame to “maximum”, keep the knob pressed in and turn it anticlockwise until the second step.

Keeping the knob pressed and turning it anticlockwise as far as it will go puts the burner in the “minimum” flame intensity position.

N.B. For elevated temperatures, it is recommended to set the knob in the “maximum” flame position, while for temperatures inferior to 200°C it is possible to modulate the intensity of the flame as required between the maximum and minimum positions.

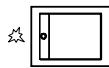

5.1.8 **PILOT LIGHT IGNITION SWITCH**

After having started the gas flowing using the knob, pressing this red switch creates a spark to ignite the pilot light.

N.B. Igniting the pilot light enables the burner. If the pilot light is lit, the burner is able to light according to the cooking parameters that have been set.

5.2 ERROR INDICATION

The electronic digital thermo-regulator can signal abnormal functioning as described in the paragraphs below.

5.2.1 Disconnected thermocouple (vers. TERM0012)

When the thermocouple is disconnected or interrupted, the display  shows "E1".

5.2.2 Disconnected thermocouple (vers. TERM0060)

When the thermocouple is disconnected or interrupted, the display  shows "E1".



5.3 LACK OF GAS OR ELECTRICITY SUPPLY

If for any reason the gas supply should be interrupted, the pilot light and the burner flame go out. The electricity supply is active as long as the command panel is on but the oven is not provided with automatic relighting so when the gas supply is restored, go on to ignite the pilot light and burner as described at paragraph 6.1.

If for any reason the electricity supply should fail, the control panel and the burner flame are turned off. As the gas is still being supplied the pilot remains alight. On restoring the electricity supply, the control panel is reactivated and the burner is automatically relit, restoring all the ovens functions according to previous settings.



6. USE

6.1 TURNING ON FOR THE FIRST TIME

 Before connecting the electricity supply to the oven, ensure that the master switch   is in the "0" position. Ensure the effectiveness of the gas connections, then open the tap to the fixed gas supply.

IMPORTANT – TURNING ON FOR THE FIRST TIME

The components of an oven new from the factory (hobs and cooking surfaces of refractory or sheet metal material) need to be subjected to an initial preheating operation. BRINGING THE OVEN UP TO TEMPERATURE OVER AN ARC OF 5-6 HOURS (1°h=100°C - 2-3°h=150°C - 4°h=200°C - 5°h=250°C - 6°h=300°C); the first time the oven is turned on, this is an INDISPENSIBLE procedure to avoid possible damages to the above mentioned parts.

Put the switch   in the "I" position

Set the digital thermo-regulator to the desired temperature (see paragraph 5.1.1 or 5.1.2).

Keep the knob  pressed for 20 seconds and rotate it in an anticlockwise direction until the first step.

Press the red pilot light ignition switch . Ignition can be checked through the hole situated near the control panel (see Fig. 6-1 Pos.1).

At this point it is possible to release the knob

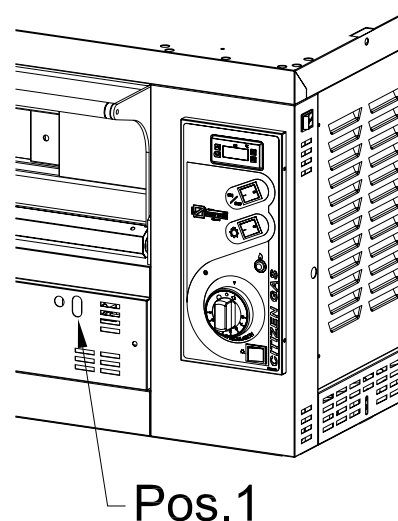
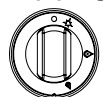



Fig. 6-1

To bring the burner up to maximum capacity, gently press the knob and rotate it once again in an anticlockwise direction until the second step. To take the burner down to its minimum capacity gently

press the knob and rotate it once again, as far as it will go, in an anticlockwise direction.

It is possible to check whether the burner is lit as indicated by the green



light  or by observing the flame through the four holes in the front panel of the burner.

After the burner has been ignited, wait until the oven reaches the temperature set; at which point the oven switches to ON/OFF mode.

6.2 PILOT LIGHT FAILS TO TURN ON



If the pilot light does not ignite, check that the gas pipe is connected and that the supply tap is open.

However, if the pilot light fails to ignite on the first attempt, it is probable that this is due to air being present in the gas supply duct. It may therefore be

necessary keep the knob  pressed for more than 20 seconds and press the red button  at brief intervals until the pilot light ignites.

6.3 RAISING AND LOWERING THE TEMPERATURE

Once the burner has been lit, the temperature in the baking chamber begins to increase until it reaches the temperature that has been set. It is possible to

change the desired temperature at any time using the  and  buttons.

When the temperature set has been reached, the burner goes out, lighting up again whenever the temperature in the chamber has dropped by 1°C lower than that set. In this way the burner oscillates between the states of ON and OFF.

If the oven does not reach the temperature set, check that the flame intensity regulation knob has not been set at a flame intensity that is not sufficient for the setting (see 5.1.7).

N.B. After having reached high operating temperatures for sustained periods, for example 340-370°C, to set a markedly lower operating temperature requires waiting some minutes until the temperature has gone down to the temperature of the new setting.

6.4 HOW TO TURN OFF THE OVEN

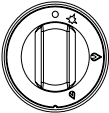
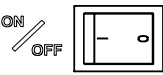
To turn off the oven, turn the knob  in a clockwise direction to the OFF position, put the master switch  in the “0” position and close the tap on the fixed gas supply conduit.

N.b. activating the master switch  cuts power to the Electrical system, the burner cuts out but the pilot light stays alight. Check that the gas ignition knob is always in the OFF position when switching off.

When the oven is left unused for long periods (for example during closure for holidays) the electricity supply to the working area must be turned off at the master switch and the gas supply turned off at the mains.

6.5 GENERAL GUIDELINES FOR COOKING

It is not possible to give precise indications of temperature and cooking time for general foodstuffs, given their enormous variety and the correspondingly varied conditions that they require.

As far as pizza and similar products are concerned, the cooking time and temperature depends on the form and the thickness of the bread base and the quantity of ingredients added to it.

It is therefore recommended to carry out some tests, (especially if you have never worked with the oven before) starting from a temperature of 320-340°C keeping the following points in mind:

1. generally, with low temperatures the product is of a better quality and is more digestible, the oven is not subjected to stress and lasts longer but with low temperatures it is necessary to lengthen the cooking time
2. With higher temperatures it is more difficult to get an evenly cooked product.
3. The oven has an **approximate** production capacity expressed in the specifications in Kg of product per hour. If this maximum production is exceeded, the temperature in the cooking chamber decreases in excess of as much as 10-20°C and will not get back up to temperature until the rate at which the oven is loaded with unbaked product is slowed down or the cooking time is increased.

6.6 WHEN THE OVEN IS UNDERUSED

When there are no products to bake, set the oven to a temperature of 250°C and bring the intensity of the burner flame down to a minimum. This ensures a saving on the consumption of gas.

7. CLEANING

 At the end of each working day (if not more often) it is necessary to carefully clean the oven and all the parts that have come in contact with cooked products. This is to avoid food substances causing deterioration and polluting both the working area and products that are subsequently cooked.

 Before cleaning is carried out, the oven should be turned off and at room temperature with the tap to the gas main having been closed and the oven disconnected from the mains electricity supply with the switch on the switchgear.

7.1 CLEANING THE REMOVEABLE PARTS

 The removable parts can be washed just like normal kitchen utensils. Dirt or residue from detergent can accumulate in certain points. To avoid this, facilitate cleaning using non pointed utensils or small brushes.

 It is not recommended to use abrasive tools (abrasive sponges or similar) because over time they take the shine off the stainless steel parts and high impact glass. The best idea is to wash the various removable parts before food residues have had time to dry up.

7.2 CLEANING THE PARTS MADE FROM CERAMIC REFRACTORY MATERIAL

To remove cooking residue from surfaces made from ceramic refractory material, use a brush. If residue is stuck to these surfaces, prise them off gently with a spatula.

 Do not use any form of liquid especially detergent because the refractory material is porous and it cannot be rinsed to remove residue that comes into contact with these surfaces.

 Do not use clearing tools which are too pointed or abrasive because the refractory material is fragile and could easily chip or even break.

7.3 CLEANING THE OVEN'S COOKING CHAMBER

To clean the stainless steel or aluminium coated sheet steel cooking chamber, use a soft moistened sponge and if needs be a weak non abrasive detergent.

If there is a consistent amount of fat deposited on the surfaces remove them first using a spatula.

 Do not use abrasive or corrosive detergents because these will cause the stainless steel to become opaque and will, quite quickly, remove the protective layer of aluminum coated sheet steel, at which point it will start to rust.

 Do not direct jets of water onto the equipment for clearing as these can penetrate through to and damage the electrical system with the consequent risk of electrocution and the equipment starting up unexpectedly.

7.4 CLEANING EXTERNAL SURFACES

To clean the external stainless steel surfaces of the control panel, use a soft moistened sponge and if needs be a weak non abrasive detergent.

 The tempered glass parts are particularly sensitive to sudden variations in temperature that can cause them to crack into tiny fragments. Do not handle glass parts and do not bring them into contact with water until they have cooled down to room temperature.

 Do not use abrasive or corrosive detergents because these will cause the stainless steel to become opaque.

 Do not direct jets of water onto the equipment for clearing as these can penetrate through to and damage the electrical system with the consequent risk of electrocution and the equipment starting up unexpectedly.

8. MAINTAINANCE

⚠ ATTENTION: these maintenance instructions are to be used exclusively by personnel qualified to install and maintain electrical and gas appliances. Maintenance work carried out by non qualified personnel could cause damage to the oven, to persons, animals or property.

⚠ To carry out repairs and routine checks it will be necessary, in most cases, to remove the safety panel. This gives access to parts conducting electricity.

Before removing any protective housing ensure that the plug supplying current to the cooking unit is disconnected from the electrical system. Put the plug to one side in a place where the service engineer can easily ensure that it has been unplugged during the entire duration of any work carried out with any safety covers removed.

8.1 CHANGING THE HALOGEN LAMP

To change the halogen lamp in the baking chamber, it is necessary to carry out the following steps:

1 - Remove the right hand panel unscrewing the 4 self tapping screws to access the electrical system.

2 - Remove the light housing cover unscrewing the 4 self tapping screws.

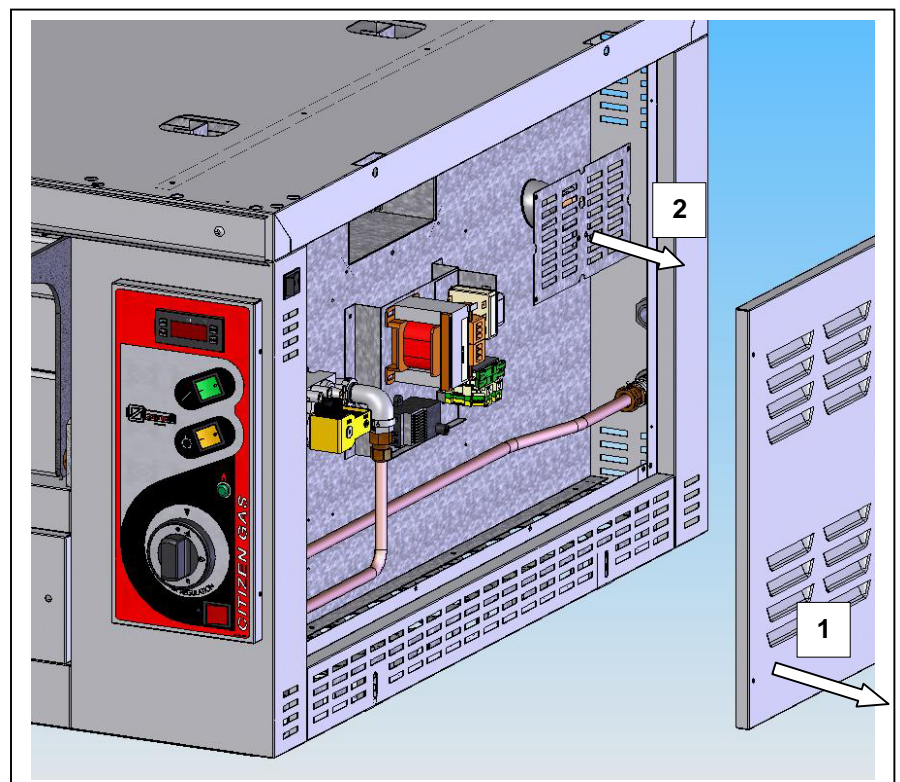

3 - Unscrew the 2 screws that fix the lamp to its holder using a flat headed screwdriver and pull it out, substituting the lamp with one of the same type.

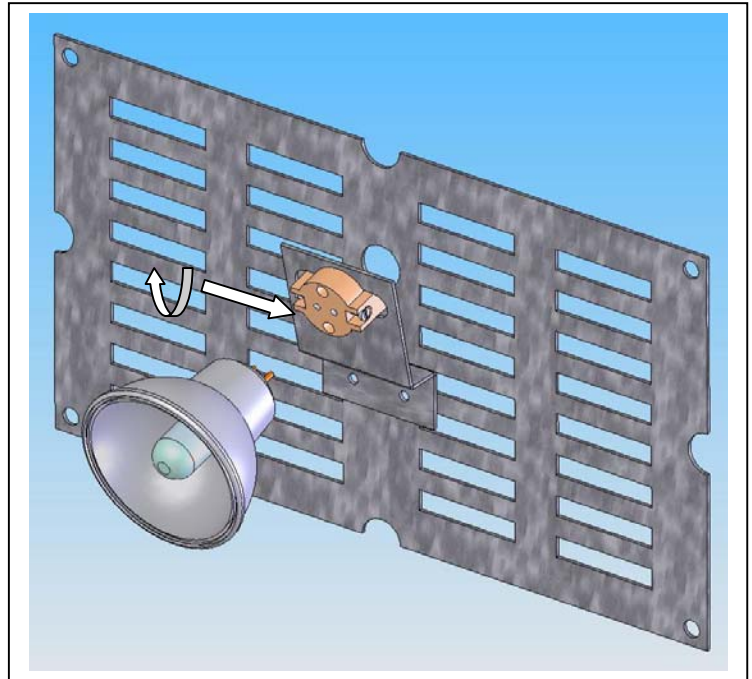

8.2 SAFETY THERMOSTAT

The safety thermostat intervenes when the temperature of the baking chamber has exceeded 500°C closing off the gas supply valve. The safety thermostat has a manual reset and is sited inside the right hand panel.

To restore the oven to use, remove the plug from the switchgear, close the gas interception valve and wait until the chamber has cooled down.

Remove the side panel to the right of the control panel and press the red safety thermostat button. Resetting will not occur until the temperature of the chamber has dropped below 500°C.

 Given that the safety thermostat only activates in the event of serious faults (for example the solenoid valve remains blocked open, faulty thermoregulator), before restarting the oven, carefully check that the oven and the abovementioned electrical components are working properly. Carry out repairs if necessary.

8.3 WIRING DIAGRAM

Fig. 8-1 shows the ovens' wiring diagram Citizen 6 e 9 gas 230 at Vac 1-N 50/60 Hz.

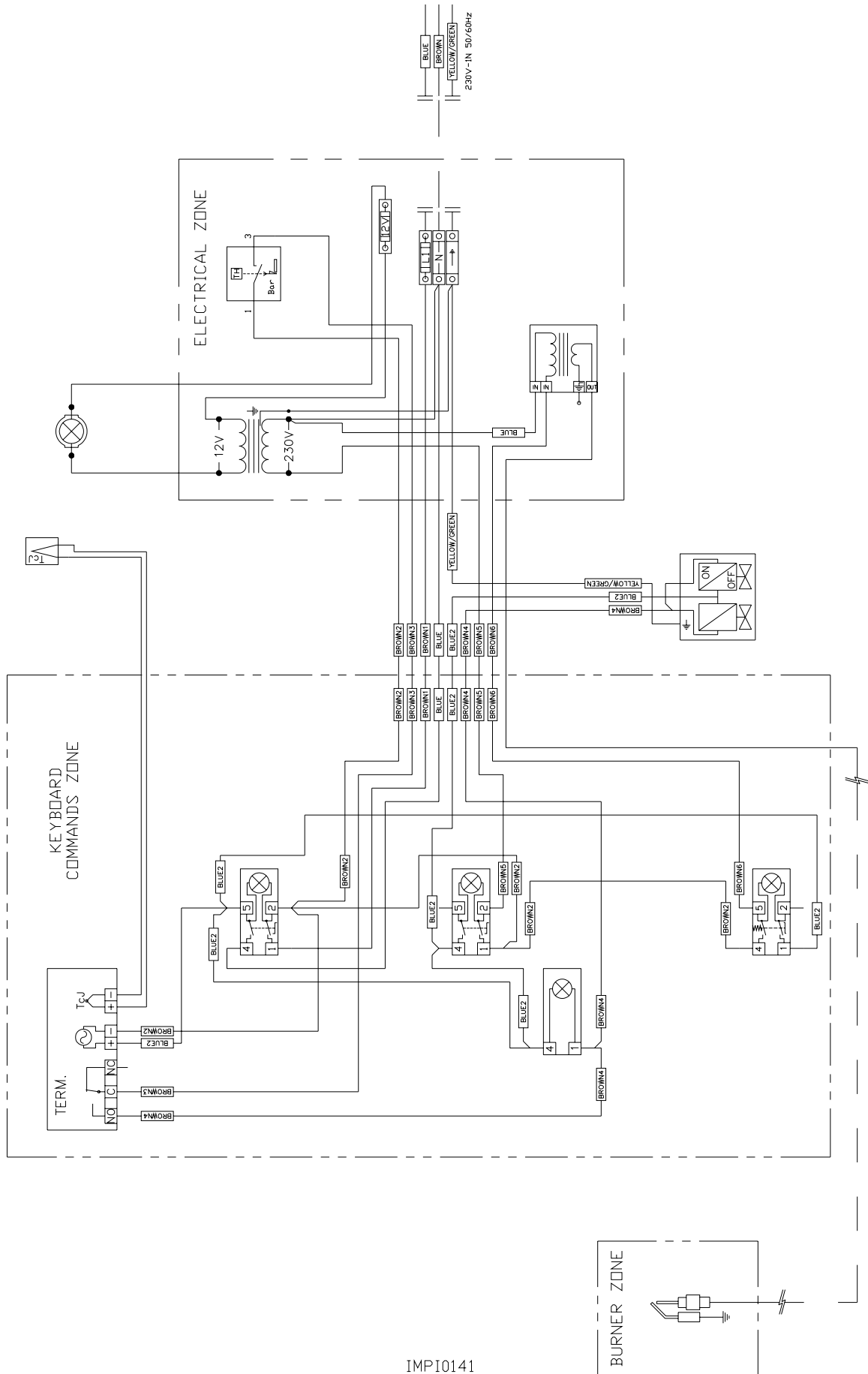

IMPI0141

Fig. 8-1 Wiring diagram CITIZEN 6 - 9 gas at 230Vac 1-N 50/60 Hz

8.4 ADAPTATION TO VARIOUS TYPES OF GAS

⚠ Attention! To adapt the cooking unit for use with a different type of gas from that indicated on the initial setting label, it is necessary to carry out the steps described in the following paragraphs:

⚠ Carefully carry out all the steps shown below. If this is not done, the cooking unit cannot be considered safe.

8.4.1 Substituting the burner/pilot jet

⚠ Check that the oven is off and at room temperature.

⚠ Remove the plug from the switchgear and shut off the tap to the mains gas supply

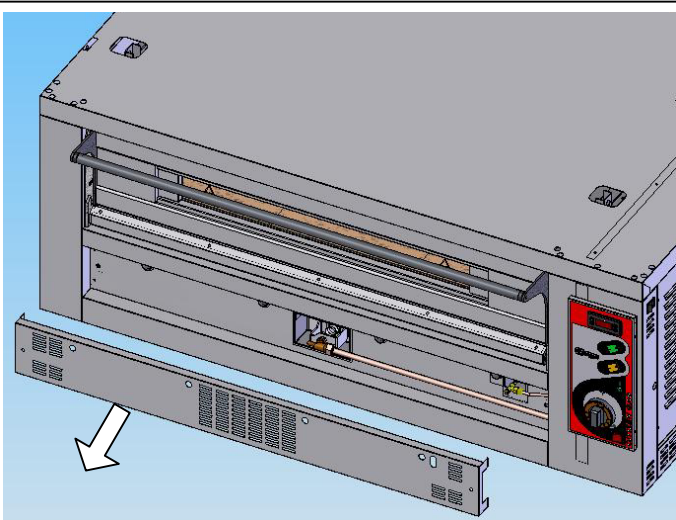

1 - Remove the burner housing safety cover unthreading the two socket head screws.

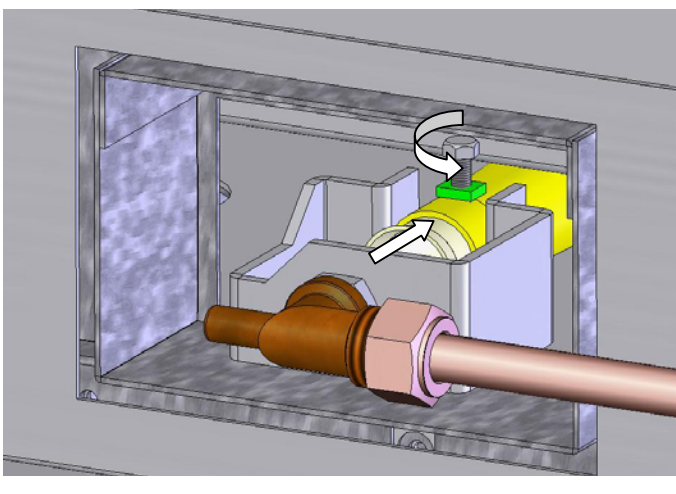

2 – Release the bolt that holds the collector tube with a number 8 spanner and slide it in to expose the gas injector.

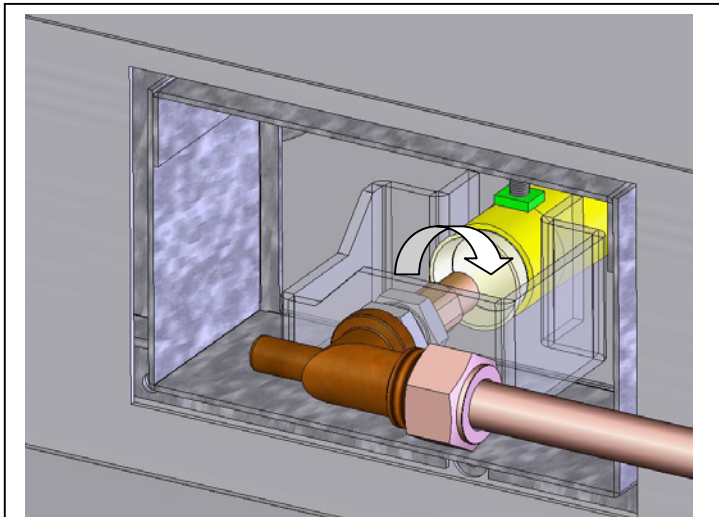

3 – Unthread the jet with a number 12 spanner and replace it with one foreseen for the new supply

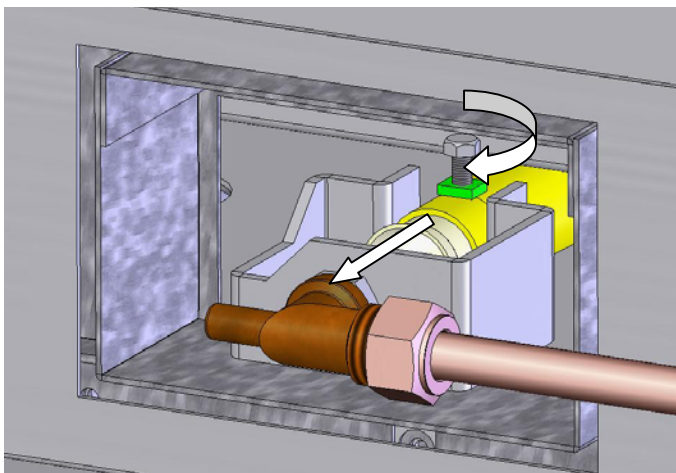

4 – Regulate the air intake according to the table (tab. 8-1) and undo the nut with a number 8 spanner.

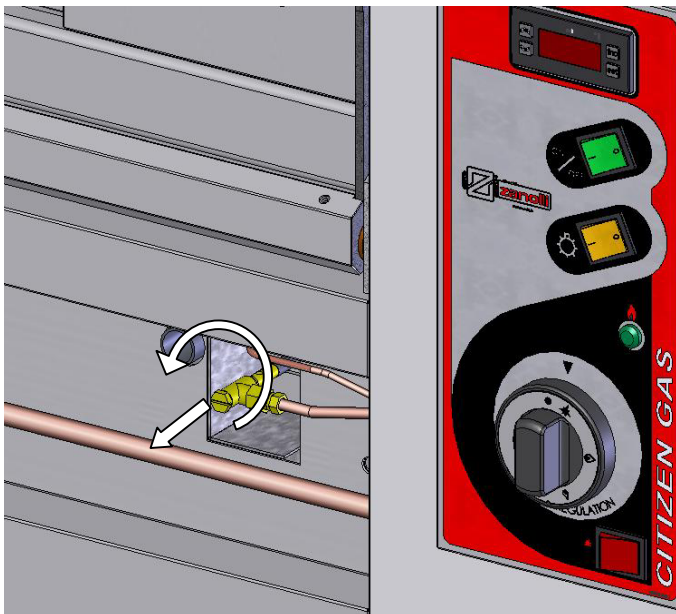
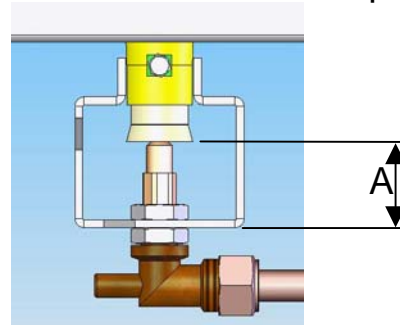

5 - Unscrew the pilot light screw with a flat headed screwdriver and replace the pilot light jet with one foreseen for the new supply (see tab. 8-1).

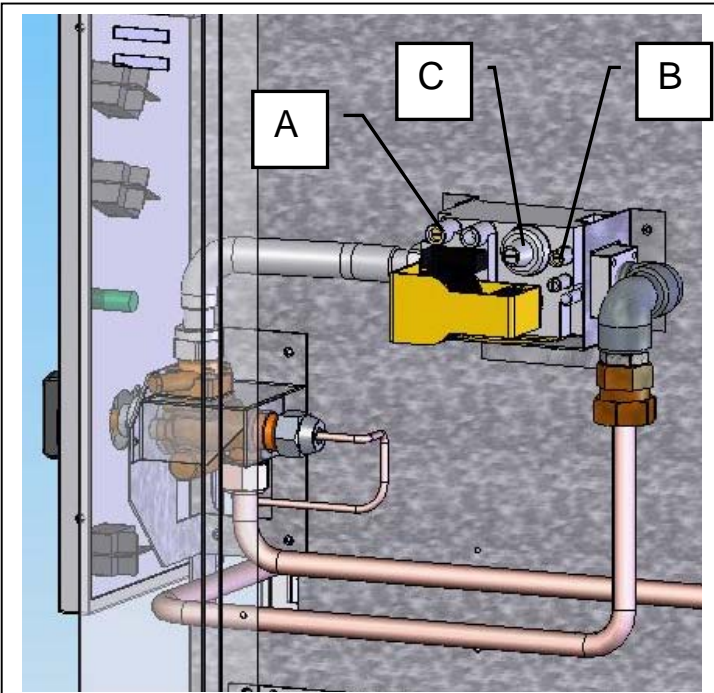

6 - Check if there are any gas leaks from the system. Take off the oven's side panel to access the area of the solenoid and electrical system.

Light the oven and set the flame intensity to "maximum".

Connect a manometer to the pressure testing socket A and verify the correct entry pressure to the solenoid valve (see table 8-1).

Connect a pressure gauge to the pressure testing socket B and check the correct exit pressure from the solenoid valve (see table 8-1) If this is verified, go on to regulate the flow with the screws that can be exposed by unscrewing screw C using a flat headed screwdriver.

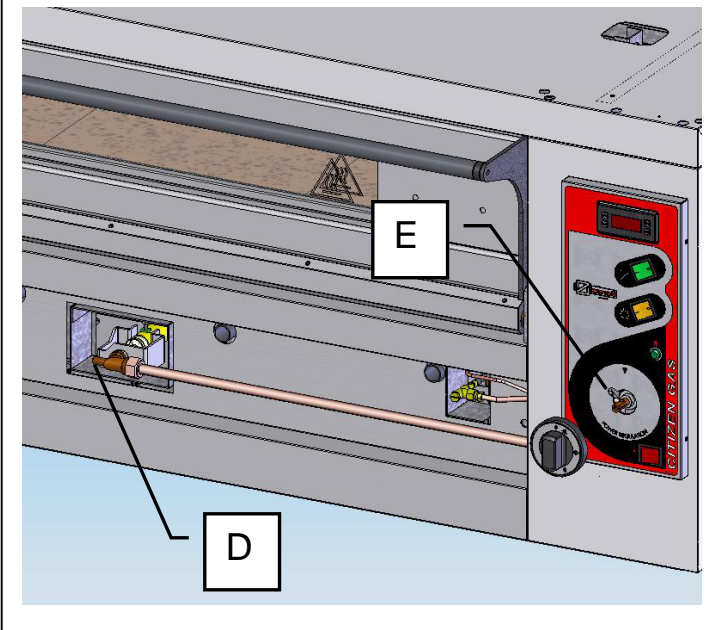

7- Set the intensity of the flame to minimum and slip the knob off the tap spindle. With the pressure gauge connected to the pressure socket D, check that the pressure is correct at the "minimum" setting (see tab. 8-1). If this is verified, go on to regulate the flow with screw E using a flat headed screwdriver.

	Citizen 6 GAS	Citizen 9 GAS	Unit of measure
Burner jet diameter according to [gas type] and pressure			
G20 - 20 mbar	3.15	3.9	Mm
G25 - 20 mbar	3.15	3.9	Mm
G25 - 25 mbar	3.15	3.9	Mm
G30 - 28..30 mbar G31 - 30..37 mbar	1.8	2.25	Mm
G30 - 50 mbar G31 - 50 mbar	1.8	2.25	Mm
Pilot jet diameter according to [gas type] and pressure			
G20 - 20 mbar	0.35	0.35	mm
G25 - 20 mbar	0.35	0.35	mm
G25 - 25 mbar	0.35	0.35	mm
G30 - 28..30 mbar G31 - 30..37 mbar	0.20	0.20	mm
G30 - 50 mbar G31 - 50 mbar	0.20	0.20	mm
Regualtion of the air supply according to [gas type] and pressure (Distance A indicated in mm)			
G20 - 20 mbar	13	23	mm
G25 - 20 mbar	13	23	mm
G25 - 25 mbar	13	23	mm
G30 - 28..30 mbar G31 - 30..37 mbar	open	open	mm
G30 - 50 mbar G31 - 50 mbar	open	open	mm
Pressure at the jet according to [gas type] and supply pressure at rated capacity			
G20 - 20 mbar	10	10	mbar
G25 - 20 mbar	15	15	mbar
G25 - 25 mbar	15	15	mbar
G30 - 50 mbar G31 - 50 mbar	28	28	mbar
Minimum pressure at the jet according to [gas type] and supply pressure			
G20 - 20 mbar	4	4	mbar
G25 - 20 mbar	6	6	mbar
G25 - 25 mbar	6	6	mbar
G30 - 28..30 mbar G31 - 30..37 mbar	10	10	mbar
G30 - 50 mbar G31 - 50 mbar	10	10	mbar

Table 8-1 gas specifications

8.4.2 Applying the new label

Remove the old label and carefully clean the area using a cloth dampened with petrol. Stick on the label showing the type and pressure of gas that the unit has been adapted to (the label, together with jet and instructions for the modification are contained in the modification kit supplied on request for each type and pressure of gas).

8.5 REPLACING THE BURNER JET

⚠ Make sure that the oven is turned off and at room temperature

⚠ Remove the plug from the switchgear and shut off the tap to the mains gas supply.

⚠ To substitute the burner it is necessary to carry out the following operations making reference to the illustrations below.

1 - Remove the 2 M6 sunk hexagonal screws so as to remove the burner housing protection.

2 - Undo the nut holding the tube where you measure the pressure at the exit point using a number 23 spanner, undo the nut holding the tube to the solenoid valve using a number 19 spanner and slip out the copper tube.

3 - Remove the second panel from the burner housing by unscrewing the 4 self threading screws using a cross headed screwdriver.

4 - Remove the third panel from the burner housing by unscrewing the 14 self threading screws using a cross headed screwdriver.

5 - Unscrew the 2 M6 screws that hold the burner in place at the base of the oven using a number 10 spanner.

6 - Extract the burner and substitute with one suitable for installation. Go on to carry out the operations described above in the reverse order checking whether there is any gas leakage from the system.

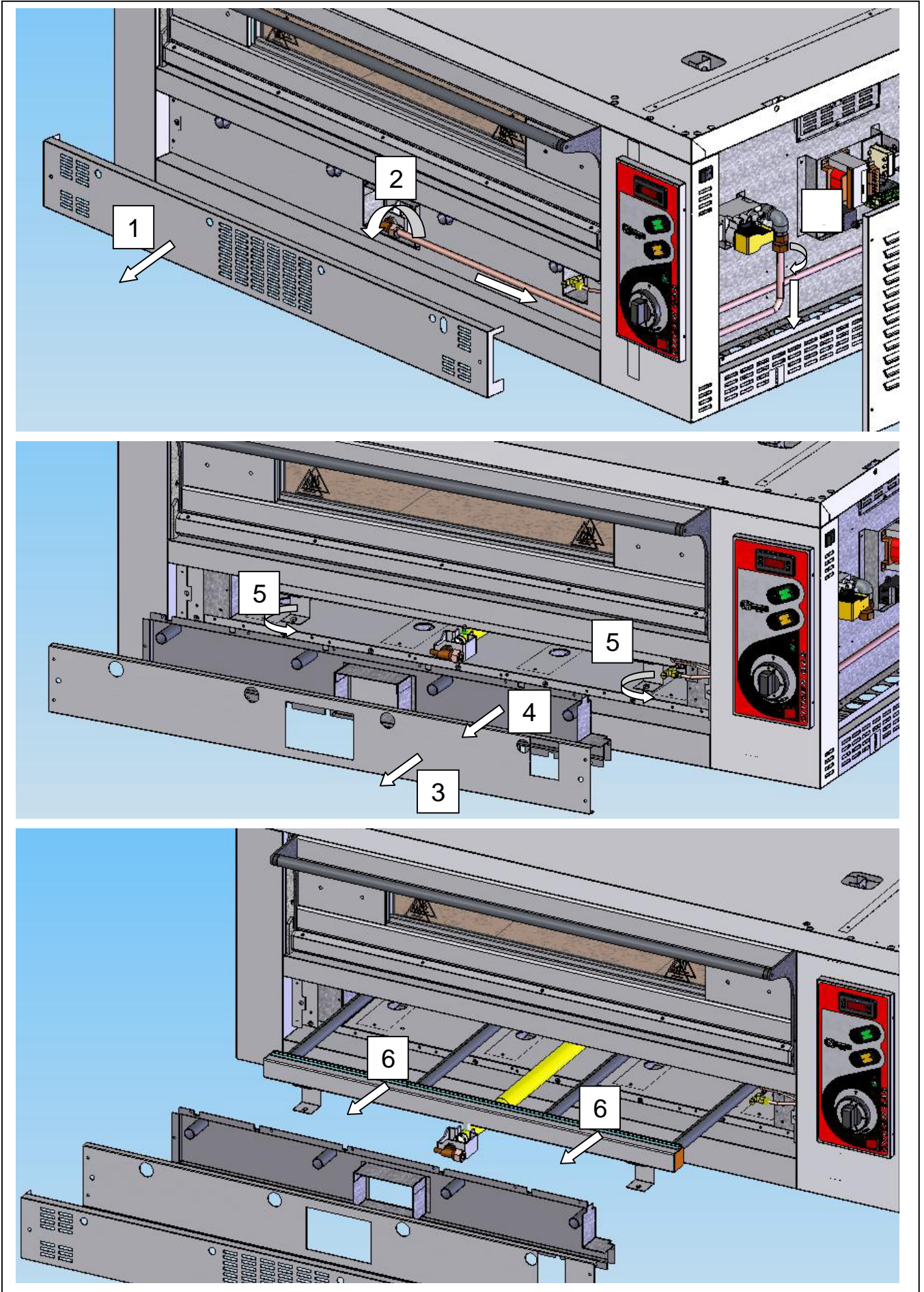

8.6 EXPLODED DIAGRAMS AND LIST OF REPLACEMENT PARTS

For more complex interventions and in the event of breakdowns please contact us. However to make it easier to find the cause of the problem and replace broken parts here is a list of spare parts and exploded drawings of the oven with reference to each listed part.

TABELLA CODICI DI RIFERIMENTO

POS	DENOMINAZIONE	CODICE	
		Citizen 6 gas	Citizen 9 gas
1	External door	PORT0353	PORT0353
2	Glass holder	PORT0319	PORT0319
3	Left plate	SUPP0206	SUPP0206
4	Tubing handle	MANI0063	MANI0063
5	Bush	BOCC0006	BOCC0006
6	Internal door	PORT0352	PORT0352
7	Door frame	PORT0350	PORT0350
8	Left side panel	FIAN0412	FIAN0413
9	Lower side crosspiece	FIAN0408	FIAN0409
10	Top	FIAN0419	
	Top front part		FIAN0421
	Top back part		FIAN0422
11	Back	FIAN0407	FIAN0407
12	Chimney	TUBO0175	TUBO0175
13	Right side panel	FIAN0415	FIAN0414
14	Lamp holder staff	CARP1671	CARP1671
15	Light glass	CRIS0006	CRIS0006
16	Command panel	CART0231	CART0231
17	Refractory material	REFR0031	REFR0032
18	Burner	BGAS0049	BGAS0050
19	Jet	-	-
20	Right staff	SUPP0207	SUPP0207
21	Burner panel	FIAN0418	FIAN0418
22	Right door spring	SPRI0010	SPRI0010
23	Left door aspring	SPRI0009	SPRI0009
24	Door glass	CRIS0028	CRIS0028

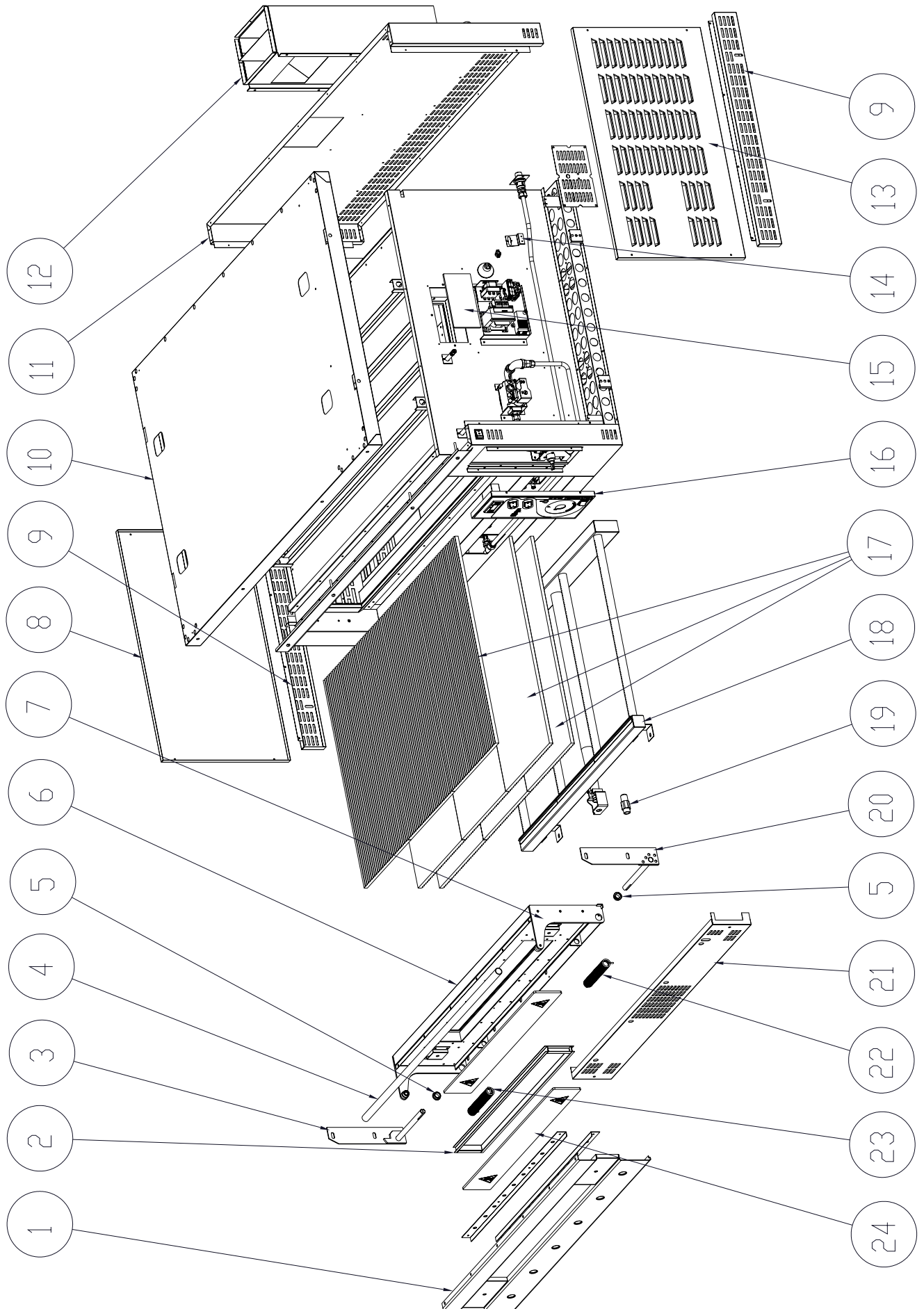
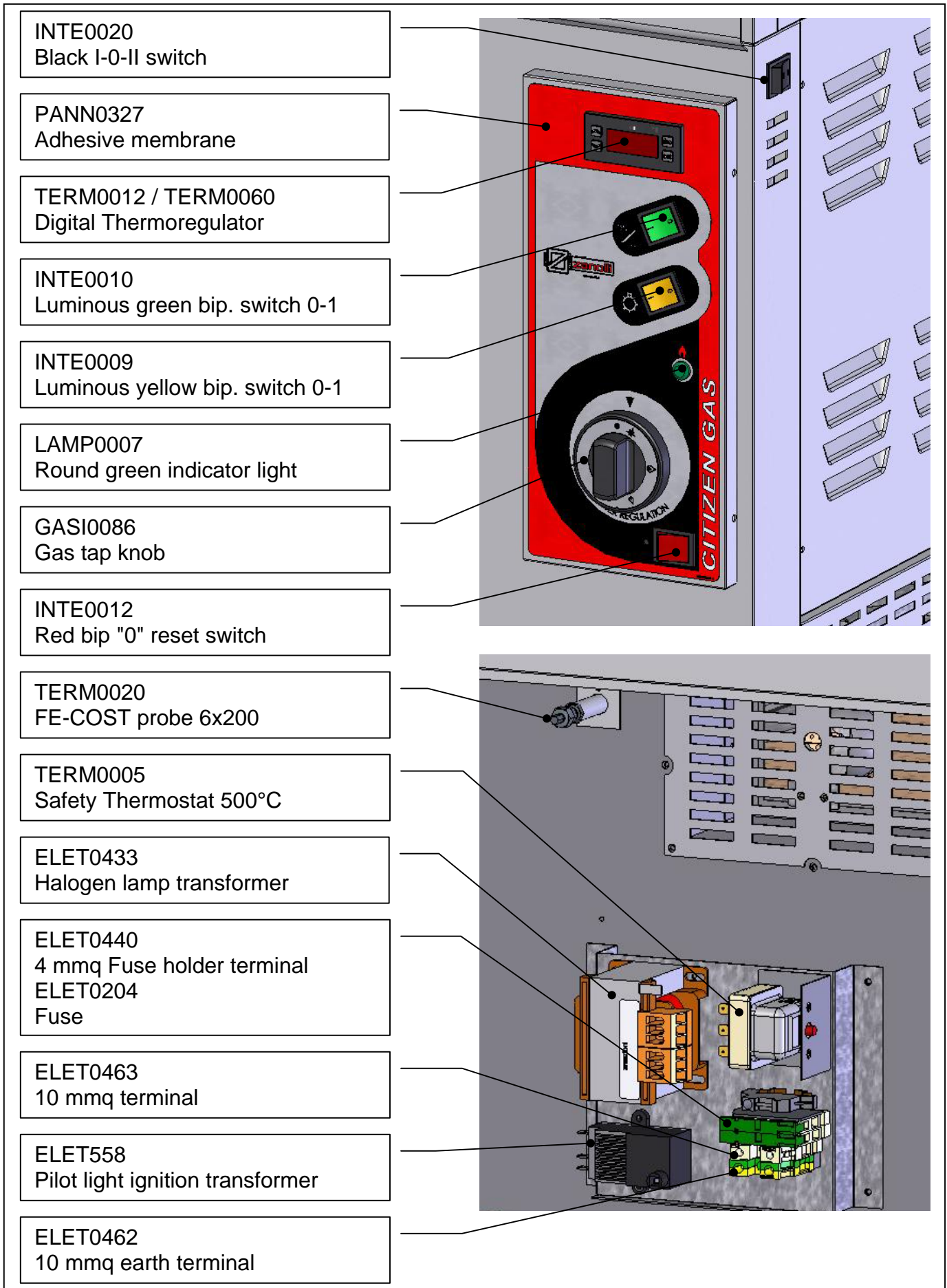

FIG. 8-2 Exploded view

CITIZEN 6-9 GAS ELECTRICAL COMPONENTS



AGAS0034
Solenoid gas valve

AGAS0035
Gas tap

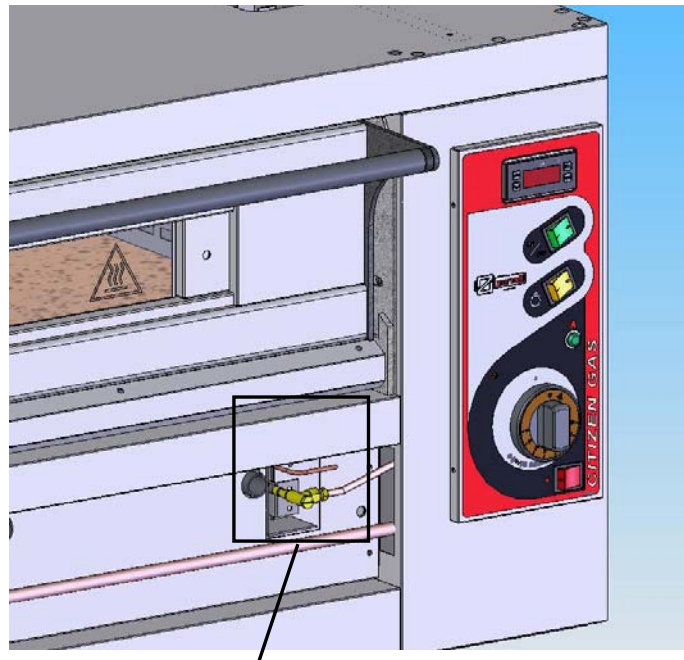
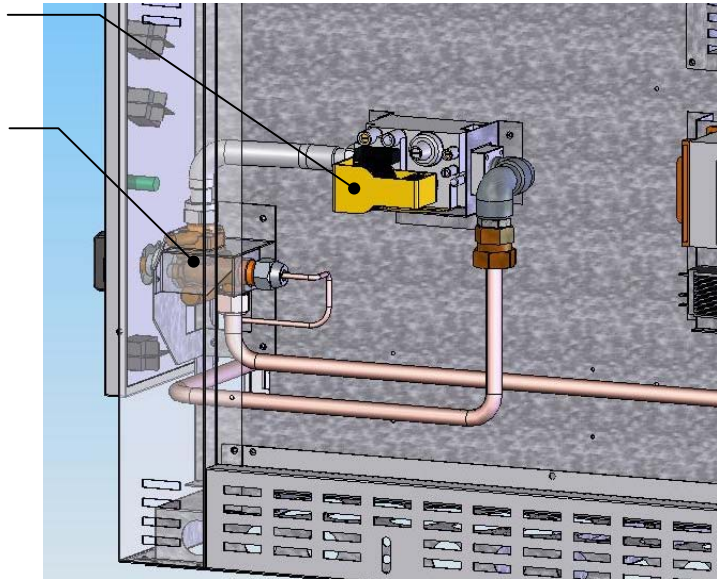

TERM0064
Pilot light thermocouple

AGAS0009
Pilot light ignition electrode

UGAS0046
Pilot jet

AGAS0010
Pilot light tap

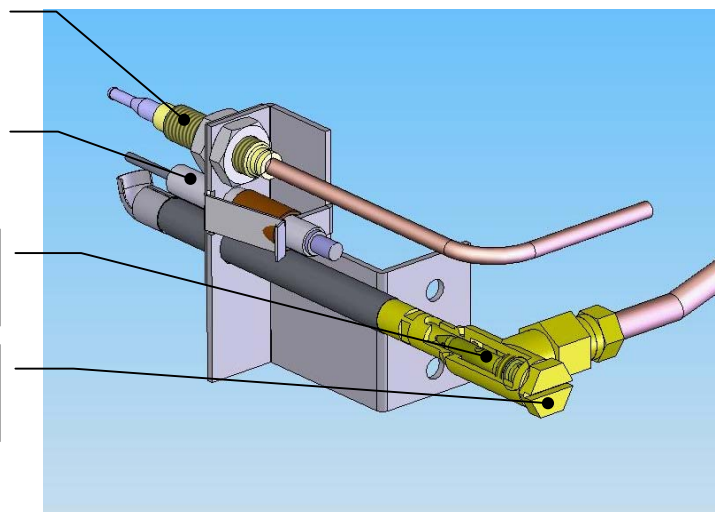

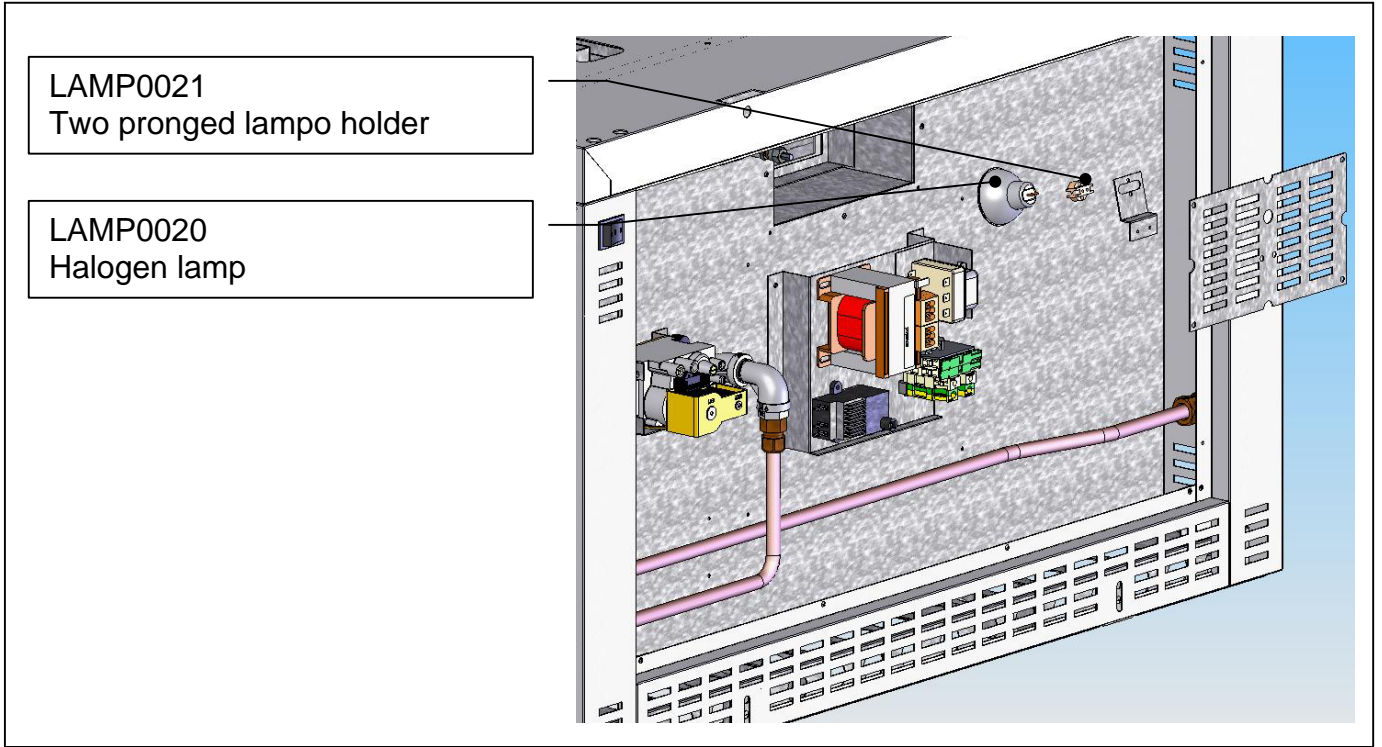

9. DECOMMISSIONING AND DEMOLITION

Before decommissioning, disconnect the electrical supply and any other connections before proceeding to move the unit by a suitable means such as a forklift truck, hoist, etc. The ovens are composed of the following materials: stainless steel, varnished sheet steel, aluminum coated sheet steel, glass, ceramic material, rock wool and electrical parts.

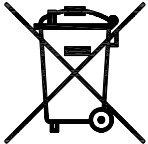

Source separation for recycling. This product must not be disposed of together with normal domestic waste. Depending on local standards and conditions, services for collecting separated waste may be available at centers provided by the local council.

10. DECLARATION OF CONFORMITY



FOODSERVICE EQUIPMENT SPARES LTD

UNIT 4 SANDBROOK PARK, SANDBROOK WAY, ROCHDALE, OL11 1RY

01706 353 633

SALES@FOODSERVICESPARES.COM



WWW.FOODSERVICESPARES.COM