



TECHNICAL DIAGRAMS



ECOSTAR 530 FM

01706 353 633

WWW.FOODSERVICESPARES.COM

Ersatzteilliste
Spare parts list
Liste de pièces détachées



Geschirr- und Gläserpülautomat
Dish- and glasswashing machines
Machine à laver la vaisselle et verres

EcoStar 530 F-M

FA



EcoStar 530 F-M FA

Inhaltsverzeichnis:	Contents:	Contenu:	Seite/ Page
01.34 Waschpumpe	Wash pump	Pompe de lavage	4
02.12 Pumpenansaugung	Pump suctioning	Aspiration de pompe	6
03.35 Wasch- und Nachspülsystem	Washing and rinsing system	Système de lavage et rinçage	8
04.32 Magnetventil	Solenoid valve	Electrovanne	10
06.09 Niveauregelung	Level control	Régulation de niveau	11
08.36 Einbauboiler	Incorporated boiler	Surchauffeur incorporé	12
09.24 Tankheizung	Tank heating	Chauffage de bac	15
10.18 Dosiergeräte	Dosing units	Doseurs	16
11.89 Elektroniksteuerung	Electronic control	Commande électronique	18
13.60 Baugruppen/Einzelteile	Component blocks/Parts	Blocs/Pièces détachées	20
18.22 Laugenpumpe	Drain pump	Pompe de vidange	21
22.27 Drucksteigerungspumpe	Booster pump	Surpresseur	22
24.07 Freier Auslauf	Air gap	Ecoulement libre	24
25.02 Türgewichtsausgleich	Door counterweight	Equilibrage de poids de porte	25

KENNZEICHNUNG DER ER-SATZTEILE

* / V DIESE TEILE EMPFEHLEN WIR AUF LAGER ZU LEGEN!
V VERSCHLEISSTEIL!

ÄNDERUNGEN IN AUSFÜHRUNG UND KONSTRUKTION VORBEHALTEN.

SPECIAL MARKS OF SPARES

WE RECOMMEND TO STORE THESE PARTS!
WEAR AND TARE PART!

WE RESERVE THE RIGHT TO CHANGE EXECUTION AND CONSTRUCTION.

MARQUAGE SPECIALES DES PIECES

NOUS RECOMMANDONS DE PRENDRE CES PIECES EN STOCK!
PIÈCE D'USURE!

NOUS NOUS RESERVONS LE DROIT DE CHANGER L'EXECUTION ET LA CONSTRUCTION.

MEIKO Maschinenbau GmbH & Co. KG

Englerstraße 3

D-77652 Offenburg

Telefon: 0781 / 203 - 0

Telefax: 0781 / 203 - 1274

www.meiko.de

e-mail: info@meiko.de

01.34 WASCHPUMPE

01.34 WASH PUMP

01.34 POMPE DE LAVAGE



PU1_34,.doc
22.03.2006/BP

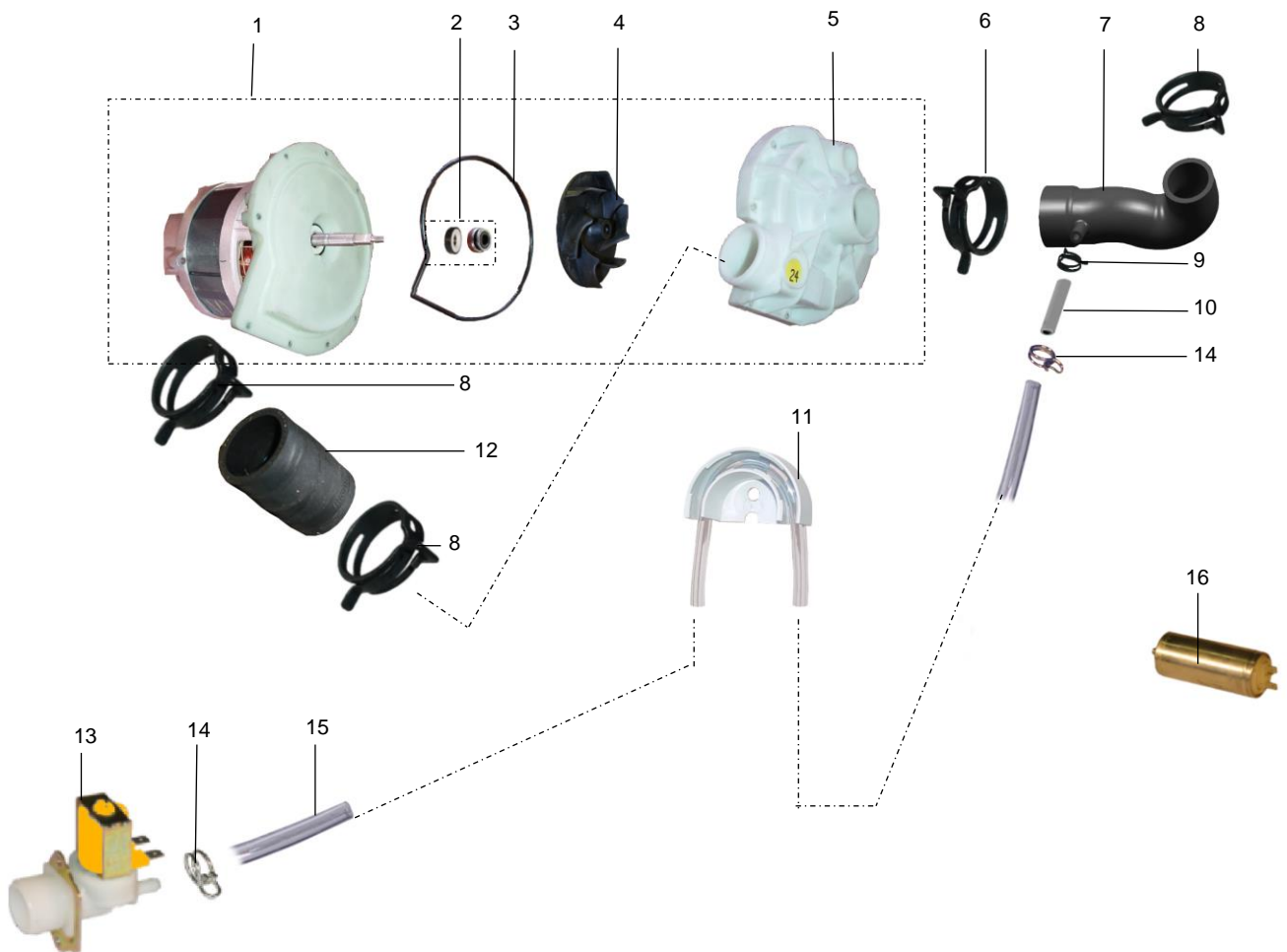

01.34 WASCHPUMPE

01.34 WASH PUMP

01.34 POMPE DE LAVAGE



PU1_34,.doc
22.03.2006/BP

POS	IDENT. NR. IDENT. NO.	BEZEICHNUNG	DESIGNATION	DESIGNATION
1	* 9623861	WASCHPUMPE 0,55 KW KPL.	WASH PUMP 0,55 KW CPL.	POMPE DE LAVAGE 0,55 KW CPL.
2	V 0501095	GLEITRINGDICHTUNG KPL.	SLIDING SEAL CPL.	JOINT AXIAL
3	* 9500310	PUMPENGEHÄUSEDICHTUNG	PACKING FOR PUMP HOUSING	JOINT POUR CORPS DE POMPE
4	* 0501137	PUMPENLAUFRAD	PUMP WHEEL	ROUE DE POMPE
5	9500311	PUMPENGEHÄUSE	PUMP HOUSING	CORPS DE POMPE
6	9624002	FEDERBANDSCHELLE Ø55	HOSE CLAMP TAPE Ø55	RUBAN COLLIER DE SERRAGE Ø55
7	9625072	SCHLAUCHVERBINDUNG	HOSE COUPLING	RACCORD POUR TUYAUX
8	9624003	FEDERBANDSCHELLE Ø50	HOSE CLAMP TAPE Ø50	RUBAN COLLIER DE SERRAGE Ø50
9	9627394	FEDERBANDSCHELLE Ø11,5	HOSE CLAMP TAPE Ø11,5	RUBAN COLLIER DE SERRAGE Ø11,5
10	9628185	ROHR Ø6	TUBE Ø6	TUYAU Ø6
11	9601265	SCHLAUCHHALTER	HOSE BRACKET	SUPPORT DE TUYAU
12	0640007	SCHLAUCH SCHWARZ Ø40 X 5	HOSE BLACK Ø40 X 5	TUYAU FLEXIBLE NOIR Ø40 X 5
13	9727359	SANFTANLAUFVENTIL 24V	SMOOTH START VALVE 24V	VALVE POUR DEMARRAGE EN DOUCEUR 24V
14	9500045	SCHLAUCHKLEMME GELB	HOSE WIRE CLAMP YELLOW	COLLIER DE SERRAGE JAUNE
15	0260007	SCHLAUCH KLARSICHT Ø6	HOSE TRANSPARENT Ø6	TUYAU TRANSPARENT Ø6
16	* 0501090	KONDENSATOR 12µF	CONDENSER 12µF	CONDENSEUR 12µF

02.12 PUMPENANSAUGUNG

02.12 PUMP SUCTIONING

02.12 ASPIRATION DE POMPE



PA02_12.doc
16.03.06/BP

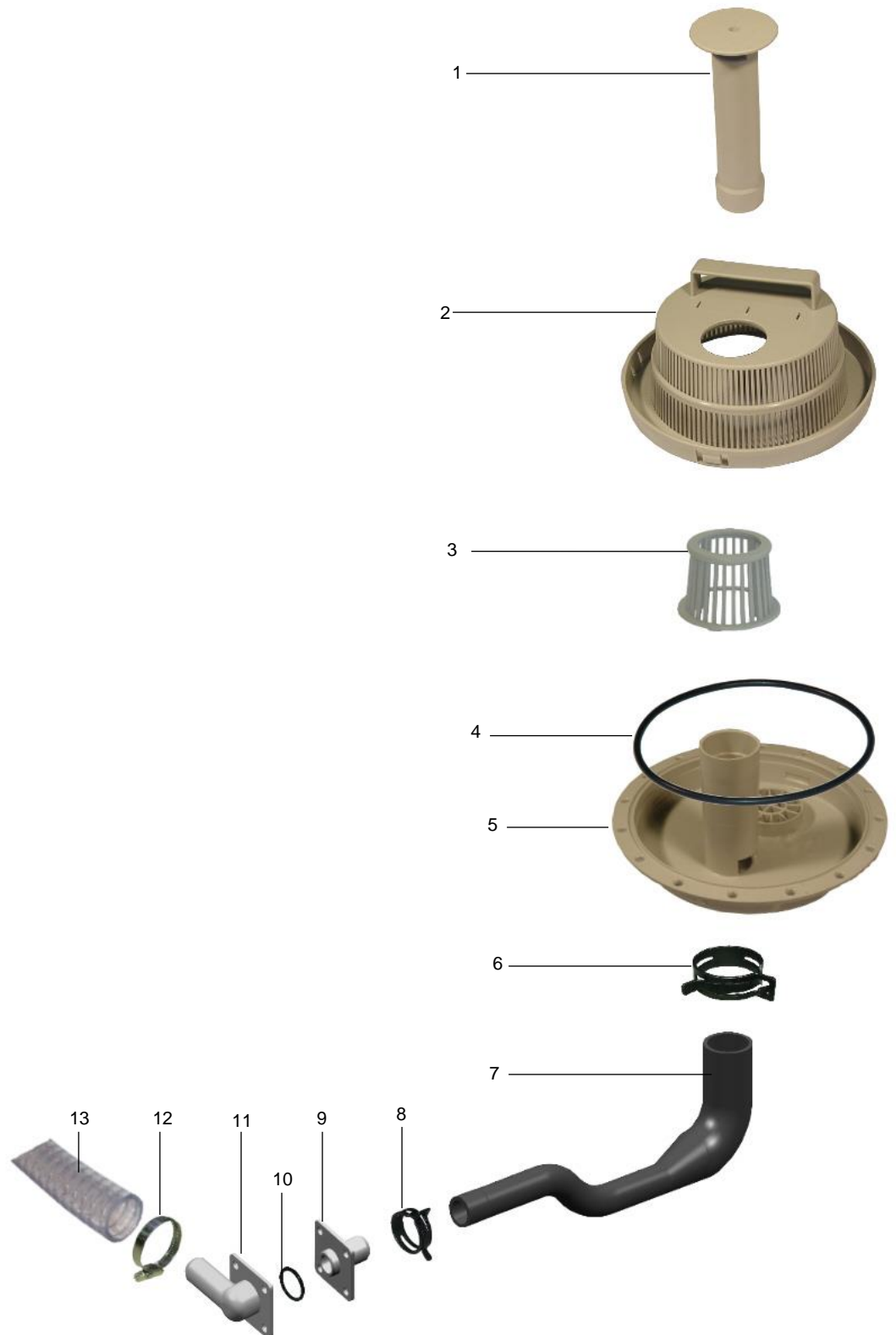

02.12 PUMPENANSAUGUNG

02.12 PUMP SUCTIONING

02.12 ASPIRATION DE POMPE



PA02_12.doc
16.03.06/BP

POS	IDENT. NR. IDENT. NO.	BEZEICHNUNG	DESIGNATION	DESIGNATION
1	0620347	STANDROHR, 140 LANG	STAND PIPE, 140 LONG	BONDE DE TROP-PLEIN, 140 LONG
2	0620346	SIEB MIT SCHMUTZRINNE K 337	FILTER WITH DIRT TRAP K 337	TAMIS AVEC PROFILE A DECHETS K 337
3	9630597	SIEB	SIEVE	TAMIS
4	* 0401061	O-RING 206,5 X 3,53	O-RING 206,5 X 3,53	BAGUE O 206,5 X 3,53
5	9625059	PUMPENSUMPF	PUMP SUMP	CUVETTE DE POMPE
6	9624003	FEDERBANDSCHELLE Ø50	HOSE CLAMP TAPE Ø50	RUBAN COLLIER DE SERRAGE Ø50
7	9625217	SCHLAUCHVERBINDUNG	HOSE COUPLING	RACCORD POUR TUYAUX
8	9607417	FEDERBANDSCHELLE Ø30	HOSE CLAMP TAPE Ø30	RUBAN COLLIER DE SERRAGE Ø30
9	9502991	SCHLAUCHANSCHLUSS	HOSE CONNECTOR	RACCORD DE TUYAU
10	* 0401017	O-RING	O-RING	BAGUE
11	9503011	SCHLAUCHANSCHLUSS	HOSE CONNECTOR	RACCORD DE TUYAU
12	0233045	SCHLAUCHKLEMME 20/32	HOSE WIRE CLAMP 20/32	COLLIER DE SERRAGE 20/32
13	9007232	ABLAUSCHLAUCH 22X3000	DRAIN HOSE 22X3000	TUYAU DE VIDANGE 22X3000
	9641540	ABLAUSCHLAUCH 22X1600	DRAIN HOSE 22X1600	TUYAU DE VIDANGE 22X1600

03.35 WASCH- UND NACHSPÜLSYSTEM

03.35 WASHING AND RINSING SYSTEM

03.35 SYSTEME DE LAVAGE ET RINCAGE



Wn3_35.doc
27.04.2006/BP

POS	IDENT. NR. IDENT. NO.	BEZEICHNUNG	DESIGNATION	DESIGNATION
1	* 9630498	STEIGLEITUNG MIT DREHARMLAGER OBEN	ASCENDING PIPE WITH WASH ARM PIVOT TOP	CONDUITE ASCENDANTE AVEC AVEC PIVOT BRAS ROTATIFS HAUT
2	9624004	FEDERBANDSCHELLE Ø43	HOSE CLAMP TAPE Ø43	RUBAN COLLIER DE SERRAGE Ø43
3	0640048	SCHLAUCH	HOSE	TUYAU FLEXIBLE
4	* 0401030	O-RING 50 X 1,5	O-RING 50 X 1,5	BAGUE O, 50 X 1,5
5	0620384	SCHRAUBKAPPE	SCREW CAP	CAPUCHON VISSE
6	V 0310010	RÄNDELSCHRAUBE	KNURLED SCREW	VIS MOLETEE
X	8001814	WASCHARM KPL.	WASH ARM CPL.	BRAS DE LAVAGE CPL.
7	0620385	WASCHARM 1, LANG SCHLITZ INNEN SCHRÄG	WASH ARM 1, LONG SLIT INTERIOR OBLIQUE	BRAS DE LAVAGE 1, LONG FENTE INTERIEURE OBLIQUE
	0620386	WASCHARM 2, LANG SCHLITZ INNEN GERADE	WASH ARM 2, LONG SLIT INTERIOR STRAIGHT	BRAS DE LAVAGE 2, LONG FENTE INTERIEURE DROITE
8	V 0620380	DREHARMNABE	UPPER ROTATING ARM	MOYEU DE BRAS ROTATIF
9	0620389	NACHSPÜLARM 1, LANG	FINAL RINSE ARM 1, LONG	BRAS DE RINCAGE FINAL 1, LONG
	0620390	NACHSPÜLARM 2, MITTEL	FINAL RINSE ARM 2, MEDIUM	BRAS DE RINCAGE FINAL 2, ME- DIUM
10	* 0620121	DRALLEINSATZ	TWISTING FLAT	AILETTE
11	* 0620157	NACHSPÜLDÜSENKAPPE	CAP FOR RINSE NOZZLE	CAPUCHON POUR GICLEUR DE RINCAGE
12	* 9623994	DREHARMLAGER UNTEN	WASH ARM PIVOT BOTTOM	PIVOT BRAS ROTATIFS BAS
13	9607418	FEDERBANDSCHELLE Ø21	HOSE CLAMP TAPE Ø21	RUBAN COLLIER DE SERRAGE Ø21
14	* 9608600	SCHLAUCH ½"	HOSE ½"	TUYAU ½"
15	9601255	T-STÜCK	T-PIECE	PIECE EN T
16	9622355	SCHLAUCHVERBINDUNG	HOSE COUPLING	RACCORD POUR TUYAUX
17	9607417	FEDERBANDSCHELLE Ø30	HOSE CLAMP TAPE Ø30	RUBAN COLLIER DE SERRAGE Ø30

04.32 MAGNETVENTIL

04.32 SOLENOID VALVE

04.32 ELECTROVANNE



MV4_32.doc
27.04.2006/BP

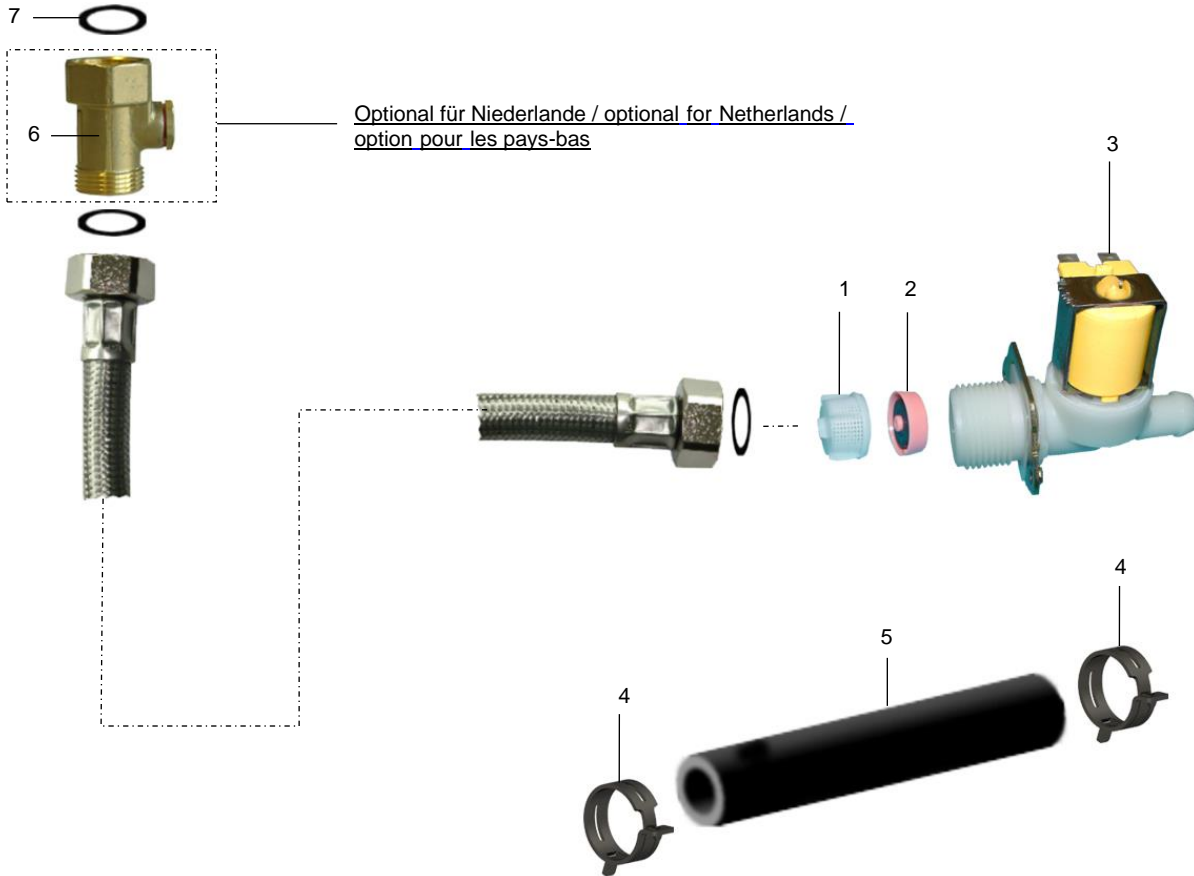

Optional für Niederlande / optional for Netherlands /
option pour les pays-bas

POS	IDENT. NR. IDENT. NO.	BEZEICHNUNG	DESIGNATION	DESIGNATION
1	0113098	MAGNETVENTILFILTERSIEB	FILTER SIEVE F. SOLENOID VALVE	TAMIS-FILTRE P. ELECTROVANNE
2	* 9511458	MENGENREGLER 5 L/ MIN.	QUANTITY REGULATOR 5 L/MIN	REGULATEUR DE QUANTITE 5 L/MIN
3	* 9686159	MAGNETVENTIL PN 10 24V GERADE AUSFÜHRUNG	SOLENOID VALVE PN 10 24V LINEAR EXECUTION	ELECTROVANNE NW 10 24V EXECUTION LINEAIRE
4	* 9609462	FEDERBANDSCHELLE Ø17	HOSE CLAMP TAPE Ø17	RUBAN COLLIER DE SERRAGE Ø17
5	* 9608607	SCHLAUCH 3/8"	HOSE 3/8"	TUYAU 3/8"
	* 9541795	SCHLAUCH 3/8" WRC-ZULASSUNG	HOSE 3/8" WRC APPROVAL	TUYAU 3/8" APPROBATION WRC
6	9627098	OPTIONAL FÜR NIEDERLANDE RÜCKSCHLAGVENTIL 3/4" ÜBER MEIKO NIEDERLANDE ERHÄLTlich	OPTIONAL FOR NETHERLANDS CHECK VALVE 3/4" AVAILABLE FROM MEIKO NETHERLAND B.V.	OPTION POUR LES PAYS-BAS CLAPET ANTI-RETOUR 3/4" DISPONIBLE CHEZ MEIKO NETHERLAND B.V.
7	* 0408225	DICHTUNG	SEAL	GARNITURE D'ÉTANCHÉITÉ

06.09 NIVEAUREGELUNG

06.09 LEVEL CONTROL

06.09 REGULATION DE NIVEAU



Nvr6_9.doc
21.03.2006/BP

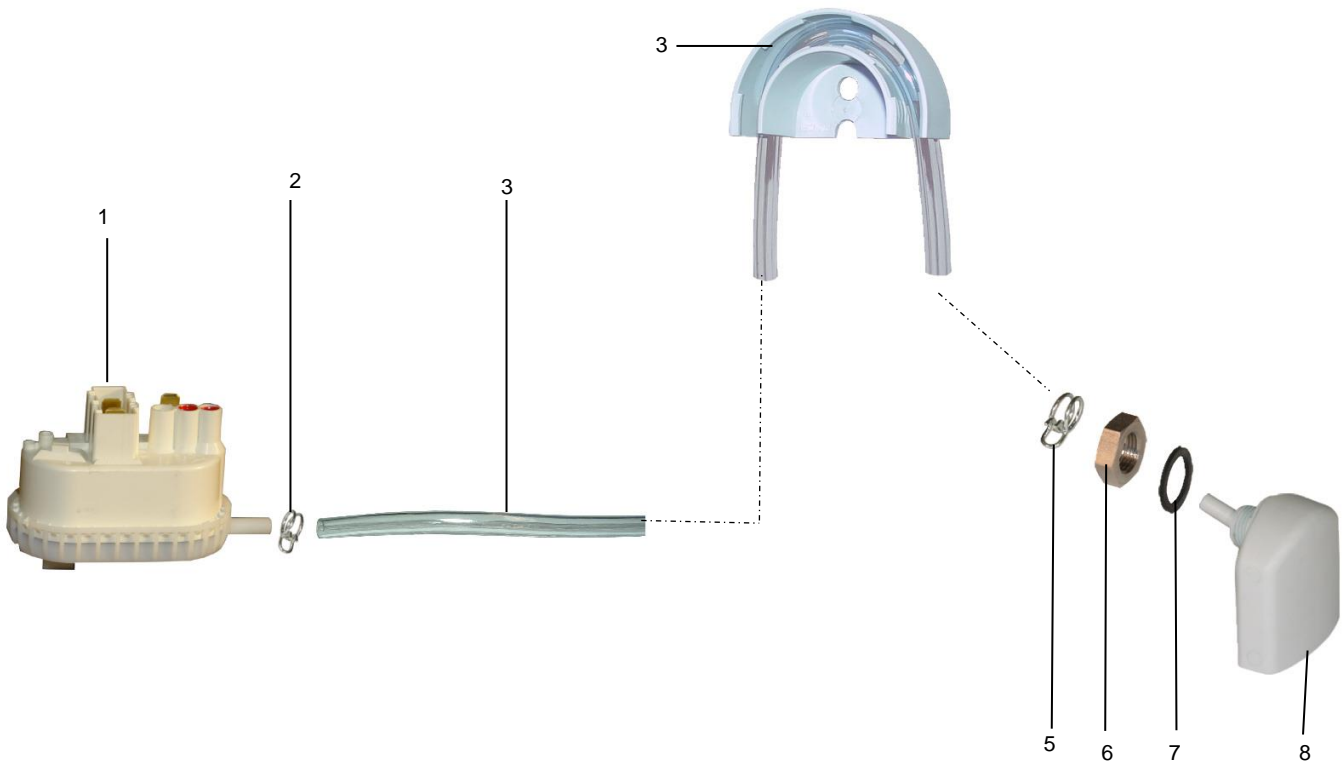

POS	IDENT. NR. IDENT. NO.	BEZEICHNUNG	DESIGNATION	DESIGNATION
1	* 9622397	NIVEAUSCHALTER 40/15	LEVEL SWITCH 40/15	INTERRUPTEUR DE NIVEAU 40/15
2	* 9500044	SCHLAUCHKLEMME SILBER	HOSE WIRE CLAMP SILVER	COLLIER DE SERRAGE ARGENT
3	* 0260006	SCHLAUCH KLARSICHT Ø5	HOSE TRANSPARENT Ø5	TUYAU TRANSPARENT Ø5
4	9601265	SCHLAUCHHALTER	HOSE BRACKET	SUPPORT DE TUYAU
5	* 9500045	SCHLAUCHKLEMME GELB	HOSE WIRE CLAMP YELLOW	COLLIER DE SERRAGE JAUNE
6	9515957	MUTTER 3/8"	NUT 3/8"	ECROU 3/8"
7	* 9515964	DICHTUNG	PACKING	JOINT
8	* 9515955	LUFTFALLE	AIR TRAP	CHAMBRE DE COMPRESSION

08.36 EINBAUBOILER

08.36 INCORPORATED BOILER

08.36 SURCHAUFFEUR INCORPORE



BH8_36.doc
01.12.2002/FUS

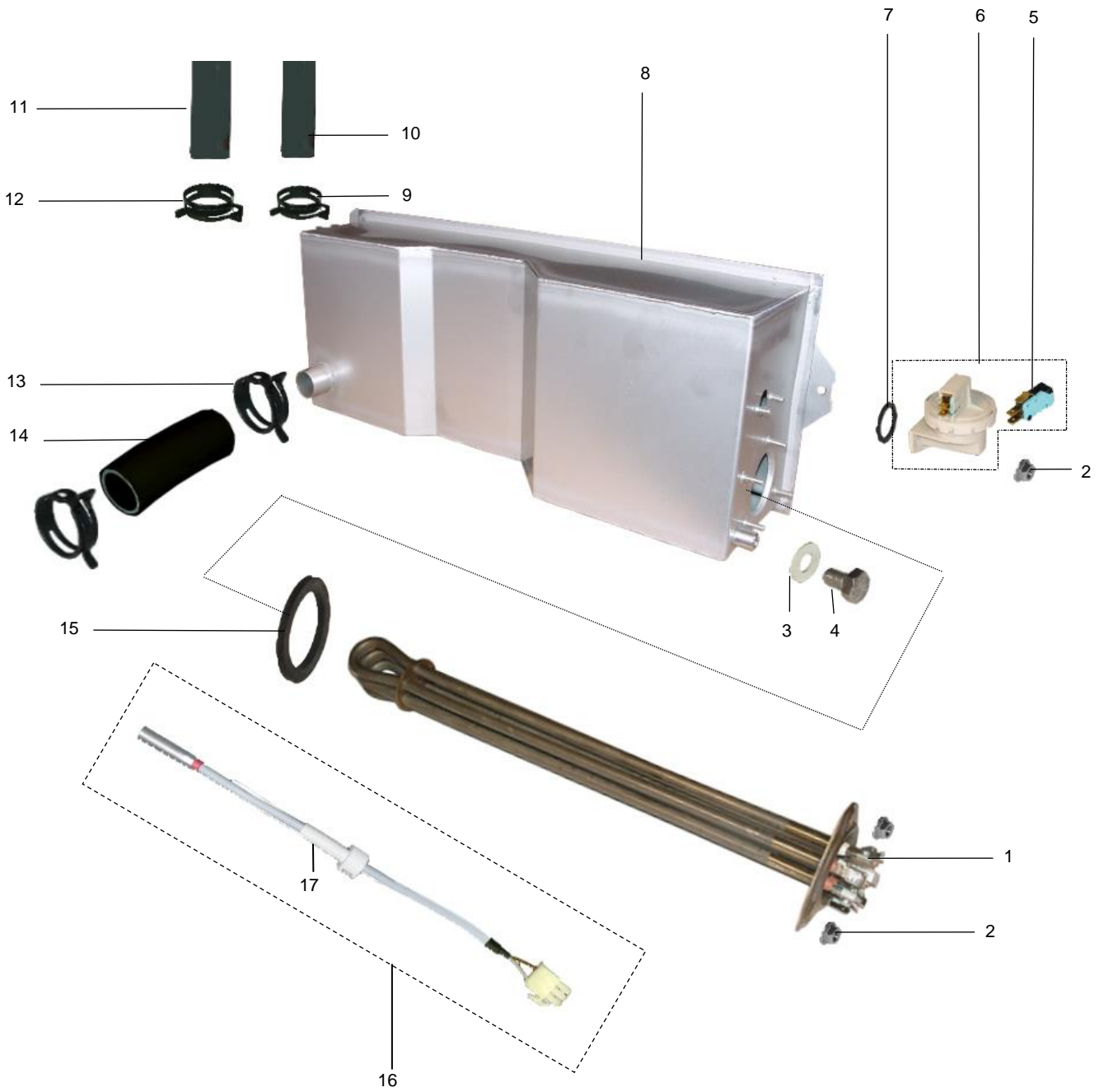

08.36 EINBAUBOILER

08.36 INCORPORATED BOILER

08.36 SURCHAUFFEUR INCORPORE



BH8_36.doc
01.12.2002/FUS

POS	IDENT. NR. IDENT. NO.	BEZEICHNUNG	DESIGNATION	DESIGNATION
1	* 9519586	HEIZKÖRPER 3 KW MIT THERMO-SICHERUNG	HEATING ELEMENT 3 KW WITH THERMAL PROTECTION	RESISTANCE 3 KW AVEC PROTECTION THERMIQUE
	* 9519587	HEIZKÖRPER 4,5 KW MIT THERMOSICHERUNG	HEATING ELEMENT 4,5 KW WITH THERMAL PROTECTION	RESISTANCE 4,5 KW AVEC PROTECTION THERMIQUE
	* 9519588	HEIZKÖRPER 6 KW MIT THERMO-SICHERUNG	HEATING ELEMENT 6 KW WITH THERMAL PROTECTION	RESISTANCE 6 KW AVEC PROTECTION THERMIQUE
	* 9519590	HEIZKÖRPER 7,5 KW MIT THERMOSICHERUNG	HEATING ELEMENT 7,5 KW WITH THERMAL PROTECTION	RESISTANCE 7,5 KW AVEC PROTECTION THERMIQUE
2	0335008	MUTTER M5	NUT M5	ECROU M5
3	* 9522687	DICHTUNG	PACKING	JOINT
4	0302006	SCHRAUBE M8X15	SCREW M8X15	VIS M8X15
5	* 0122103	MIKROSCHALTER	SWITCH	INTERRUPTEUR
6	* 9683764	NIVEAUSCHALTER KPL	LEVEL SWITCH CPL	INTERRUPTEUR DE NIVEAU CPL
7	* 0401014	O-RING 18X2	O-RING 18X2	BAGUE 18X2
8	9603367	EINBAUBOILERGEHÄUSE KPL	BOILER HOUSING CPL	BOITE DE SURCHAUFFEUR CPL
9	9609462	FEDERBANDSCHELLE Ø17	HOSE CLAMP TAPE Ø17	RUBAN COLLIER DE SERRAGE Ø17
10	9607596	SCHLAUCH 3/8"	HOSE 3/8"	TUYAU 3/8"
11	9607590	SCHLAUCH 1/2"	HOSE 1/2"	TUYAU 1/2"
12	9607418	FEDERBANDSCHELLE Ø21	HOSE CLAMP TAPE Ø21	RUBAN COLLIER DE SERRAGE Ø21
13	9607416	FEDERBANDSCHELLE Ø36	HOSE CLAMP TAPE Ø36	RUBAN COLLIER DE SERRAGE Ø36
14	9659370	SCHLAUCH 28 X 4 - 45 FÜR FV40.2/60.2/70.2/ TOPCLEAN60	HOSE 28 X 4 - 45 FOR FV40.2/60.2/70.2/ TOPCLEAN60	TUYAU 28 X 4 - 45 POUR FV40.2/60.2/70.2/ TOPCLEAN60
	9005525	SCHLAUCH 28 X 4 - 55	HOSE 28 X 4 - 55	TUYAU 28 X 4 - 55
	9008618	SCHLAUCH 28 X 4 - 100 FÜR ECOSTAR 530F-M FA	HOSE 28 X 4 - 100 FOR ECOSTAR 530F-M FA	TUYAU 28 X 4 - 100 POUR ECOSTAR 530F-M FA
15	* 9726489	HEIZKÖRPERDICHTUNG	HEATING ELEMENT PACKING	JOINT DE RESISTANCE
		GÜLTIG BIS 2005-03	VALID UNTIL 2005-03	VALABLE JUSQU'AU 2005-03
	* 9642324	TEMPERATURFÜHLER MONTAGEBAUGRUPPE	TEMPERATURE PROBE ASSEMBLY	SONDE DE TEMPERATURE JEU DE MONTAGE
	9639301	KABELSCHELLE	CABLE CLIP	COLLIER DE CABLE
		GÜLTIG AB 2005-04	VALID FROM 2005-04	VALABLE A PARTIR DU 2005-04
16	* 9640339	TEMPERATURFÜHLER MONTAGEBAUGRUPPE.	TEMPERATURE PROBE ASSEMBLY	SONDE DE TEMPERATURE JEU DE MONTAGE
17	9639301	KABELSCHELLE	CABLE CLIP	COLLIER DE CABLE

09.24 TANKHEIZUNG

09.24 TANK HEATING

09.24 CHAUFFAGE DE BAC



TH9_24.doc
20.03.2006/BP

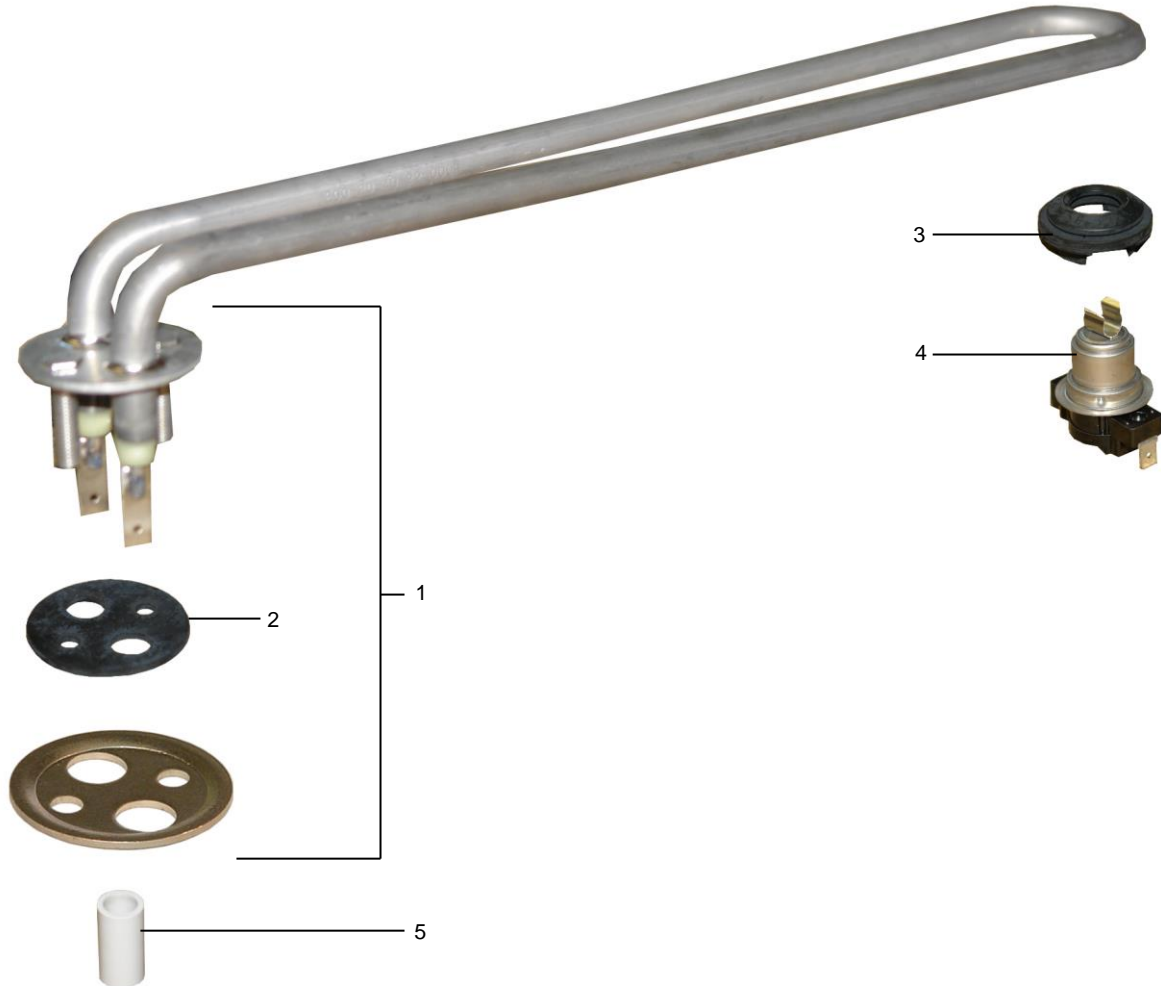

POS	IDENT. NR. IDENT. NO.	BEZEICHUNG	DESIGNATION	DESIGNATION
1	* 0101152	HEIZKÖRPER 2 KW, 230 V	HEATING ELEMENT 2 KW, 230 V	RESISTANCE 2 KW, 230 V
2	* 0101175	HEIZKÖRPERDICHTUNG	HEATING ELEMENT PACKING	JOINT DE RESISTANCE
3	* 0108040	GUMMIMANSCHETTE	RUBBER PACKING	MANCHETTE EN CAOUTCHOUC
4	* 0108043	TEMPERATURBEGRENZER	TEMPERATURE LIMITER	LIMITEUR DE TEMPERATURE
5	9543319	BERÜHRUNGSSCHUTZ	PROTECTION AGAINST CONTACT	PROTECTION CONTRE CONTACT

10.18 DOSIERGERÄTE

10.18 DOSING UNITS

10.18 DOSEURS



DOS10_18.doc
22.03.2006/BP

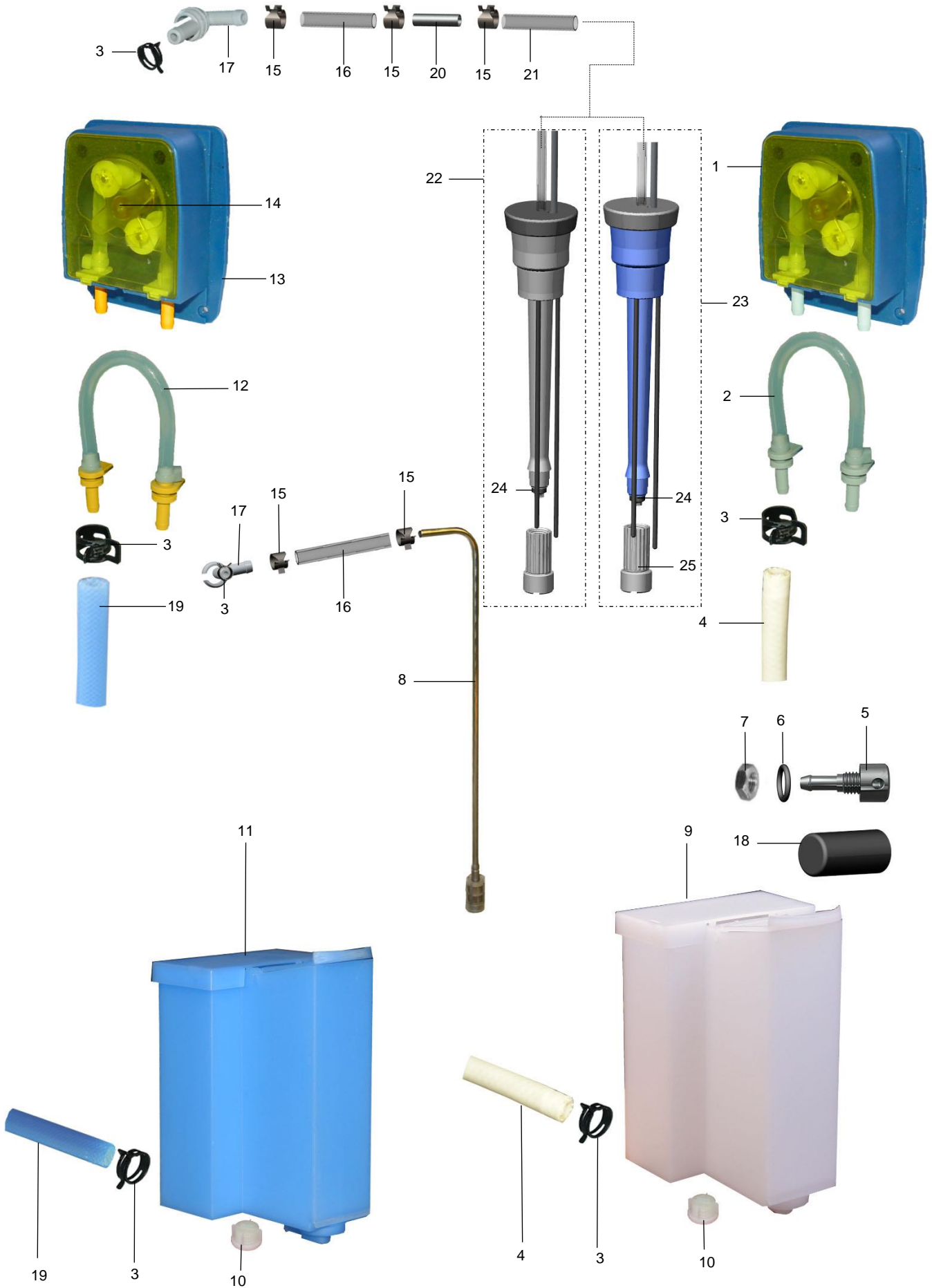

10.18 DOSIERGERÄTE

10.18 DOSING UNITS

10.18 DOSEURS



DOS10_18.doc
22.03.2006/BP

POS	IDENT. NR. IDENT. NO.	BEZEICHNUNG	DESIGNATION	DESIGNATION
1	9544292	REINIGERDOSIERPUMPE KPL	DETERGENT DOSING PUMP CPL.	POMPE DE DOSAGE DETERGENT CPL.
2	V 9511675	SCHLAUCH REINIGER KPL	HOSE DETERGENT CPL.	TUYAU DETERGENT CPL.
3	* 9717749	FEDERBANDSCHELLE Ø12,5	HOSE CLAMP TAPE Ø12,5	RUBAN COLLIER DE SERRAGE Ø12,5
4	V 9647876	SCHLAUCH NORPRENE BEIGE Ø6	HOSE NORPRENE BEIGE Ø6	TUYAU NORPRENE BEIGE Ø6
5	9541142	SCHLAUCHANSCHLUß	HOSE CONNECTION	CONNEXION DE TUYAU FLEXIBLE
6	* 9603787	FLACHDICHTUNG 10X16X2	FLAT PACKING 10X16X2	GARNITURE PLATE 10X16X2
7	* 9603790	FEDERSCHEIBE M10	SPRING WASHER M10	RONDELLE ÉLASTIQUE M10
8	0335019	SECHSKANTMUTTER	HEXAGON NUT	ECROU A SIX PANS
9	8005372	ANSAUGROHR, 420 MM	SUCTION TUBE, 420 MM	CONDUITE D'ASPIRATION 420 MM
	8005393	ANSAUGROHR, 340 MM	SUCTION TUBE, 340 MM	CONDUITE D'ASPIRATION 340 MM
10	9630369	REINIGERBEHÄLTER	DETERGENT CONTAINER	CONTENEUR DE DETERGENT
11	0113098	MAGNETVENTILFILTERSIEB	FILTER FOR SOLENOID VALVE	TAMIS-FILTRE D'ELECTROVANNE
12	9630379	KLARSPÜLERBEHÄLTER	RINSE AID CONTAINER	CONTENEUR DE PRODUIT TENSIO-ACTIF
13	V 9505652	SCHLAUCH KLARSPÜLER KPL.	HOSE RINSE AID CPL.	TUYAU PRODUIT TENSIO ACTIF CPL.
14	9625978	KLARSPÜLDOSIERPUMPE KPL.	RINSE AID DOSING PUMP CPL.	POMPE DE DOSAGE TENSIO ACTIF CPL.
	0265021	TRICHTER	FUNNEL	ENTONNOIR
15	* 9533450	ROTOR	ROTOR	ROTOR
16	9655015	FEDERBANDSCHELLE Ø 9	HOSE CLAMP TAPE Ø 9	RUBAN COLLIER DE SERRAGE Ø 9
17	V 0260007	SCHLAUCH KLARSICHT 6 X 1,5 FÜR REINIGER	HOSE TRANSPARENT 6 X 1,5 FOR DETERGENT	TUYAU TRANSPARENT 6 X 1,5 POUR DETERGENT
	V 9538712	SCHLAUCH KLARSICHT BLAU 6 X 1,5 FÜR KLARSPÜLER	HOSE TRANSPARENT BLUE 6 X 1,5 FOR RINSE AID	TUYAU TRANSPARENT BLEU 6 X 1,5 POUR PRODUIT TENSIO ACTIF
18	9661146	DOPPELNIPPEL NATUR	DOUBLE NIPPLE WHITE	NIPPLE DOUBLE BLANC
	9665221	DOPPELNIPPEL BLAU	DOUBLE NIPPLE BLUE	NIPPLE DOUBLE BLEU
19	9646131	VERSCHLUSSKAPPE	CLOSING CAP	CAPOUCHON
20	V 9681110	SCHLAUCH SILIPRESS BLAU Ø6	HOSE SILIPRESS BLUE Ø6	TUYAU SILIPRESS BLEU Ø6
21	9628185	ROHR	TUBE	TUYAU
22	0275106	SCHLAUCH Ø 8	HOSE Ø 8	TUYAU FLEXIBLE Ø 8
23	9687569	SAUGLANZE GRAU REINIGER 5L	SUCTION LANCE GREY DETERGENT 5L	LANCE D'ASPIRATION GRIS DÉTERGENT 5L
	9687598	SAUGLANZE GRAU REINIGER 10L	SUCTION LANCE GREY DETERGENT 10L	LANCE D'ASPIRATION GRIS DÉTERGENT 10L
24	9685453	SAUGLANZE BLAU KLARSPÜLER 5L	SUCTION LANCE BLUE RINSE AGENT 5L	LANCE D'ASPIRATION BLEU PRODUIT DE RINÇAGE 5L
	9685436	SAUGLANZE BLAU KLARSPÜLER 10L	SUCTION LANCE BLUE RINSE AGENT 10L	LANCE D'ASPIRATION BLEU PRODUIT DE RINÇAGE 10L
25	* 9668691	DICHTRING	SEAL	GARNITURE D'ÉTANCHÉITÉ
26	* 9680377	RÜCKSCHLAGVENTIL	CHECK VALVE	CLAPET ANTI-RETOUR

11.89 ELEKTRONIKSTEUERUNG

11.89 ELECTRONIC CONTROL

11.89 COMMAND DE ELECTRONIQUE

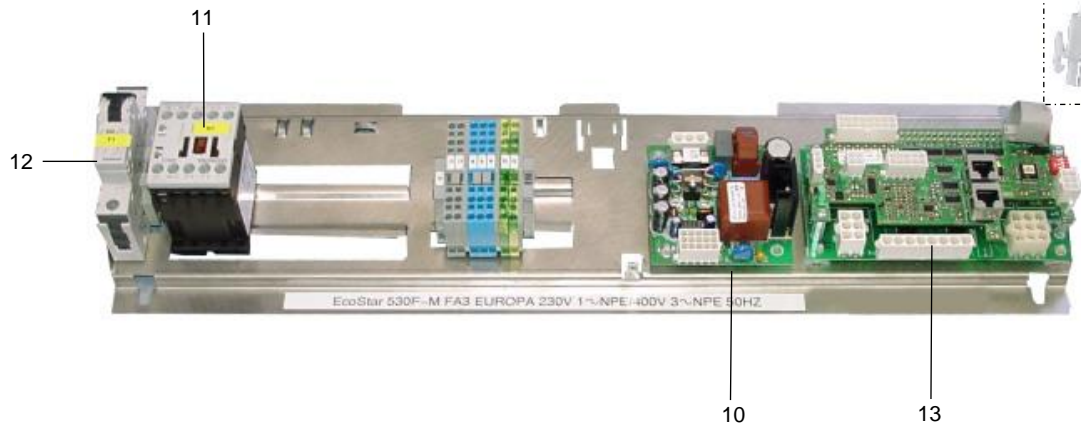
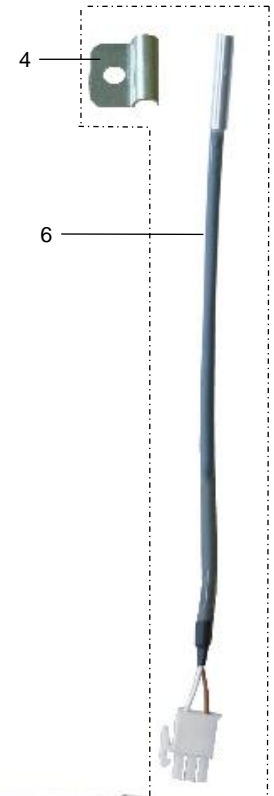

11.89 ELEKTRONIKSTEUERUNG

11.89 ELECTRONIC CONTROL

11.89 COMMAND DE ELECTRONIQUE



EL11_89.doc
2009-04-28/BP

POS	IDENT. NR. IDENT. NO.	BEZEICHNUNG	DESIGNATION	DESIGNATION
1	* 9641668	FOLIENASTATUR ECOSTAR 530F-M	SENSOR TOUCH PANEL ECOSTAR 530F-M	CLAVIER SENSITIF ECOSTAR 530F-M
2	* 9656774	FOLIENASTATUR ECOSTAR 530F-M EW	SENSOR TOUCH PANEL ECOSTAR 530F-M EW	CLAVIER SENSITIF ECOSTAR 530F-M EW
3	* 9542049	MONTAGESATZ ANZEIGENPLATINE	ASSEMBLY KIT SCALE CIRCUIT BOARD	KIT D'INSTALLATION UNITE CEN- TRALE PLATINE D'AFFICHAGE
4	9639363	HALTER	SUPPORT	APPUI
5	* 9541525	MONTAGESATZ CPU	ASSEMBLY KIT CPU	KIT D'INSTALLATION UNITE CEN- TRALE
6	* 9640338	TEMPERATURFÜHLER TANK	TEMPERATURE PROBE TANK	SONDE DE TEMPERATURE BAC
7	9607101	KABELBINDERHALTER	CABLE TIE SUPPORT	SUPPOR D'ATTACHE-CABLE
8	* 0122106	HEBEL FÜR MIKROSCHALTER	LEVER FOR SENSITIVE SWITCH	LEVIER POUR MICRORUPTEUR
9	* 0122103	MIKROSCHALTER	SWITCH	INTERRUPTEUR
10	* 9626264	NETZTEIL	POWER UNIT	BLOC DE 'ADIMENTATION
11	* 9547516	SCHÜTZ	CONTACTOR	CONTACTEUR
12	* 9612715	SICHERUNGSAUTOMAT	FUSE BLOCK	COUPE CIRCUIT AUTOMATIQUE
13	* 9678638	E/A1 PLATINE	E/A1 CIRCUIT BOARD	E/A1 PLATINE
	* 0145047	FEINSICHERUNG 2A	FINE WIRE FUSE 2A	FUSIBLE FIN 2A
	* 9611761	FEINSICHERUNG 16A	FINE WIRE FUSE 16A	FUSIBLE FIN 16A
	* 9540550	FLACHBANDKABEL 1000 MM	FLAT CABLE 1000 MM	CABLE PLAT 1000 MM
	9621015	EPROM	EPROM	EPROM
		E-EPROM MASCHINENBEZOGEN BESTELLEN (SERIENNUMMER)	E-EPROM TO BE ORDERED AC- CORDING TO EXECUTION OF MACHINE (SERIAL NUMBER)	LE E-EPROM DOIT ETRE COM- MANDE SELON L'EXECUTION DE LA MACHINE (NUMERO DE SERIE)

13.60 BAUGRUPPEN / EINZELTEILE

13.60 COMPONENT BLOCKS / PARTS

13.60 BLOCS / PIECES DETACHEES



BE13_60.doc
2009-04-29/BP



POS	IDENT. NR. IDENT. NO.	BEZEICHNUNG	DESIGNATION	DESIGNATION
1	9613827-03	SEITENVERKLEIDUNG LINKS	SIDE CLADDING, LEFT	REVETEMENT LATERAL GAUCHE
2	8005361	ABDECKUNG	COVER	RECOUVREMENT
	9534416	ABDECKUNG EW	COVER IS	RECOUVREMENT AI
3	9647506	TÜR KPL.	DOOR CPL.	PORTE CPL
4	9613827-04	SEITENVERKLEIDUNG RECHTS	SIDE CLADDING, RIGHT	REVETEMENT LATERAL DROIT
5	9613719	FRONTBLECH FÜR 2 VORRATS- BEHÄLTER	FRONT SHEET FOR 2 CONTAINER	TOLE FRONTALE POUR 2 RECI- PIENTS
	9624403	FRONTBLECH FÜR 1 VORRATS- BEHÄLTER	FRONT SHEET FOR 1 CONTAINER	TOLE FRONTALE POUR 1 RECI- PIENTS
	9624339	FRONTBLECH OHNE VORRATS- BEHÄLTER	FRONT SHEET WITHOUT CON- TAINER	TOLE FRONTALE SANS RECI- PIENT
6	9644328	FRONTBLLENDE	FRONTPANEL	PANNEAU FRONTAL
7	9613834	RÜCKWAND	CLADDING, BACK	REVETEMENT ARRIERE
	9622370	RÜCKWAND EW	CLADDING, BACK IS	REVETEMENT ARRIERE AI
	9617174	BODENBLECH	BOTTOM SHEET	TÔLE INSÉRIEUR
	9505089	ZULAUFSCHLAUCH	DISCHARGE HOSE	TUYAU DE VIDANGE
		FÜR GROSSBRITANNIEN	FOR GREAT BRITAIN	POUR GRANDE-BRETAGNE
	9500011	ZULAUFSCHLAUCH WRC-ZULASSUNG	HOSE WATER SUPPLY WRC APPROVAL	TUYAU DE RACCORDEMENT D'EAU APPROBATION WRC
	9681111	DOPPELRÜCKSCHLAGVENTIL BEI EW 10	DOUBLE CHECK VALVE AT EW 10	CLAPET ANTI-RETOUR DOUBLE CHEZ EW 10
	0460035	KUNSTSTOFF-FUSS	PLASTIC FOOT	PIED EN PLASTIC
	9651361	ECKGLEITSCHIENE FÜR DRAHT- KORB	CORNER GLIDING RAIL FOR WIRE BASKETS	RAIL DE GUIDAGE EN ANGLE POUR PANIER A FIL RILSAN

18.22 LAUGENPUMPE

18.22 DRAIN PUMP

18.22 POMPE DE VIDANGE



LP18_21.doc
2006-02-10/BP

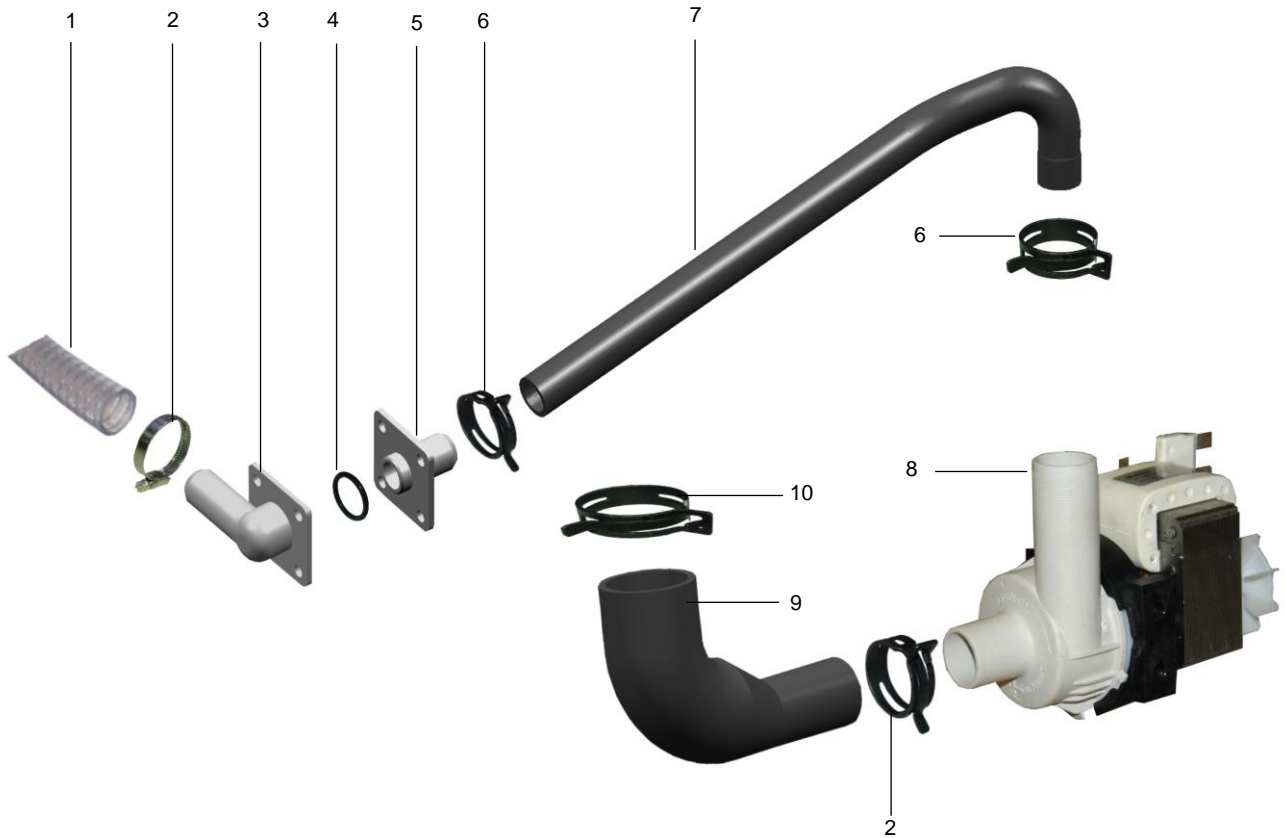

POS	IDENT. NR. IDENT. NO.	BEZEICHNUNG	DESIGNATION	DESIGNATION
1	9007232	ABLAUFSCHLAUCH 22X3000	DRAIN HOSE 22X3000	TUYAU DE VIDANGE 22X3000
	9641540	ABLAUFSCHLAUCH 22X1600	DRAIN HOSE 22X1600	TUYAU DE VIDANGE 22X1600
2	0233045	SCHLAUCHKLEMMME 20/32	HOSE WIRE CLAMP 20/32	COLLIER DE SERRAGE 20/32
3	9503011	SCHLAUCHANSCHLUSS	HOSE CONNECTOR	RACCORD DE TUYAU
4	* 0401017	O-RING	O-RING	BAGUE
5	9502991	SCHLAUCHANSCHLUSS	HOSE CONNECTOR	RACCORD DE TUYAU
6	9607417	FEDERBANDSCHELLE Ø30	HOSE CLAMP TAPE Ø30	RUBAN COLLIER DE SERRAGE Ø30
7	9623821	SCHLAUCH	HOSE	TUYAU
8	* 9624073	LAUGENPUMPE KPL. 200-240V / 50HZ / 0,07KW	DRAIN PUMP CPL. 200-240V / 50HZ / 0,07KW	POMPE DE VIDANGE CPL. 200-240V / 50HZ / 0,07KW
9	9625209	SCHLAUCHVERBINDUNG	HOSE COUPLING	RACCORD POUR TUYAUX
10	9624003	FEDERBANDSCHELLE Ø50	HOSE CLAMP TAPE Ø50	RUBAN COLLIER DE SERRAGE Ø50

22.27 DRUCKSTEIGERUNGSPUMPE

22.27 BOOSTER PUMP

22.27 SURPRESSEUR

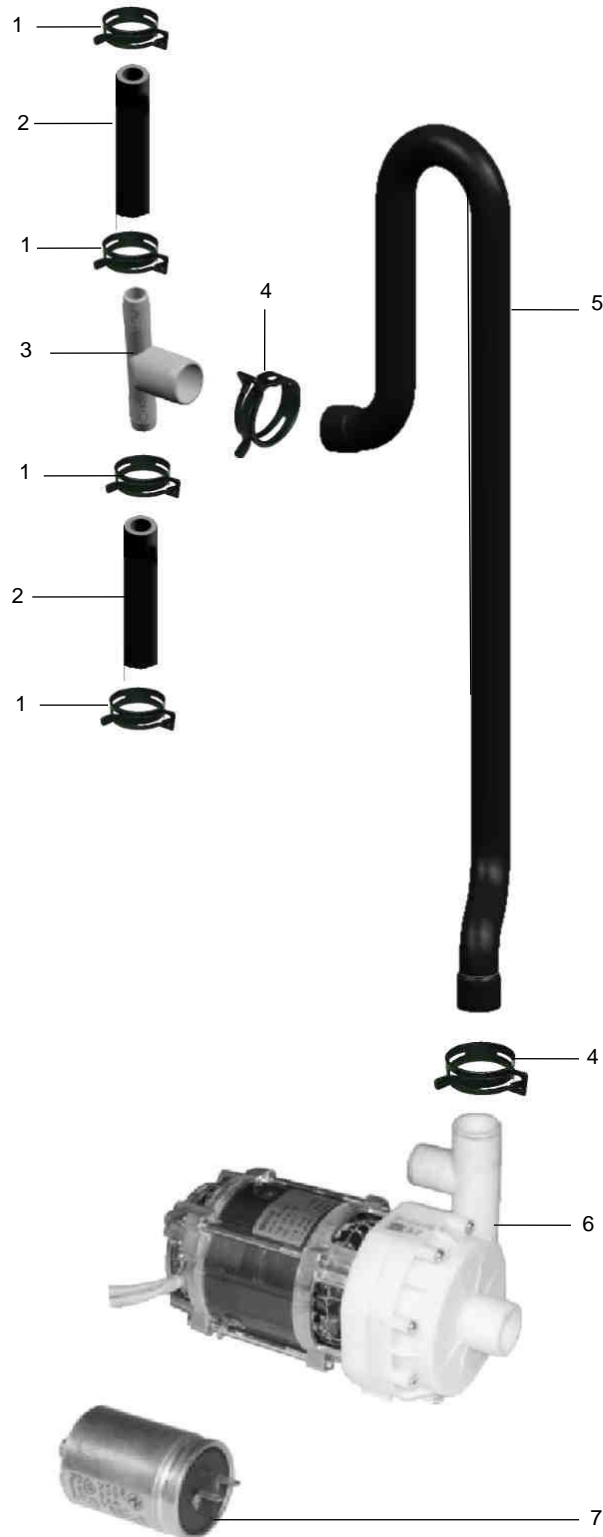

22.27 DRUCKSTEIGERUNGSPUMPE

22.27 BOOSTER PUMP

22.27 SURPRESSEUR



DSP22_27.doc
2006-04-27/BP

POS	IDENT. NR. IDENT. NO.	BEZEICHNUNG	DESIGNATION	DESIGNATION
1	9607418	FEDERBANDSCHELLE Ø21	HOSE CLAMP TAPE Ø21	RUBAN COLLIER DE SERRAGE Ø21
2	9608600	SCHLAUCH ½"	HOSE ½"	TUYAU ½"
3	9601255	SCHLAUCHVERTEILER	DISTRIBUTION PIPE	DISTRIBUTION DE TUYAU
4	9607417	FEDERBANDSCHELLE Ø30	HOSE CLAMP TAPE Ø30	RUBAN COLLIER DE SERRAGE Ø30
5	9622355	SCHLAUCHVERBINDUNG	HOSE COUPLING	RACCORD POUR TUYAUX
6	* 9638029	DRUCKSTEIGERUNGSPUMPE 200-240V 0,2 KW 50 HZ	BOOSTER PUMP 200-240V 0,2 KW 50 HZ	SURPRESSEUR 200-240V 0,2 KW 50 HZ
	* 9643336	PUMPENLAUFRAD 50 HZ	PUMP WHEEL 50 HZ	ROUE DE POMPE 50 HZ
V	9523844	GLEITRINGDICHTUNG KPL.	SLIDING SEAL CPL.	JOINT AXIAL CPL.
	* 9523260	O-RING	O-RING	BAGUE
	9643335	PUMPENGEHÄUSE	PUMP HOUSING	CORPS DE POMPE
7	* 9520030	KONDENSATOR	CONDENSER	CONDENSEUR

24.07 FREIER AUSLAUF

24.07 AIR GAP

24.07 ECOULEMENT LIBRE



Fa24_7.doc
01.12.2002/FUS

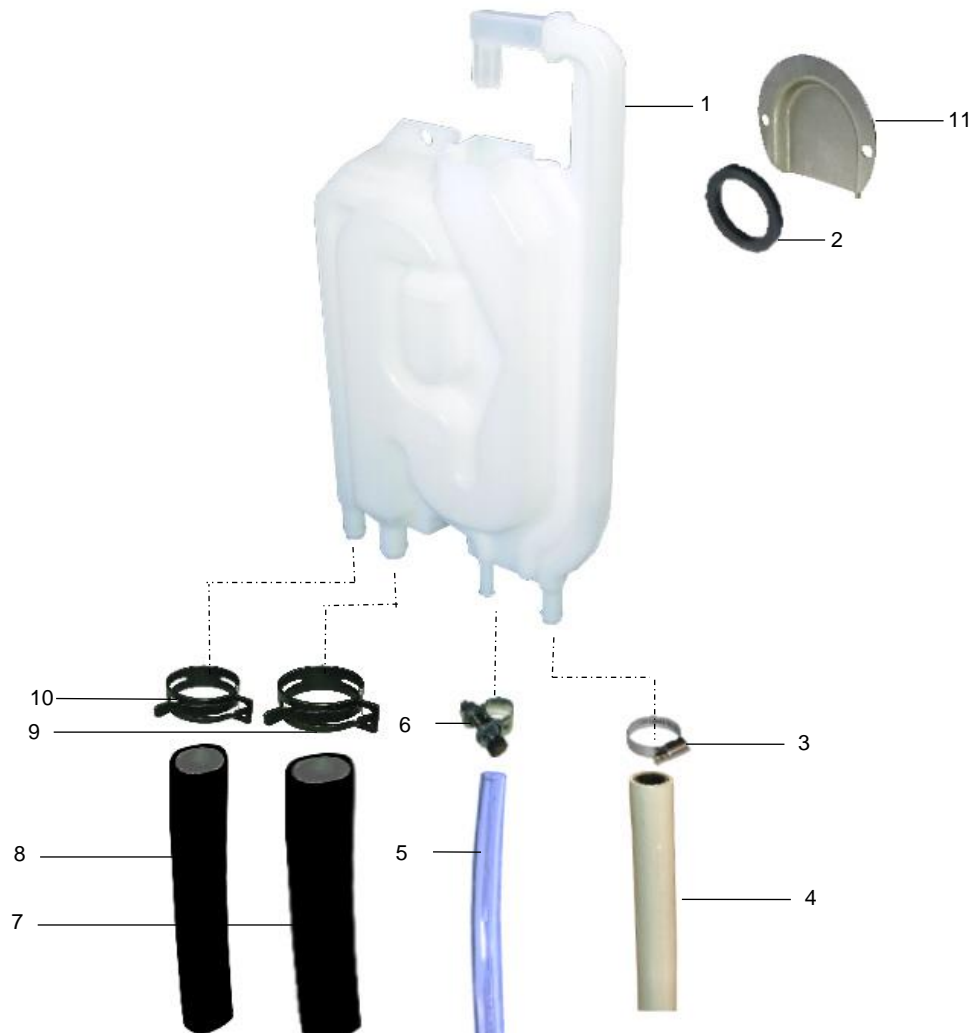

POS	IDENT. NR. IDENT. NO.	BEZEICHNUNG	DESIGNATION	DESIGNATION
1	* 9523195	FREIER AUSLAUF KPL.	AIR GAP CPL.	ECOULEMENT LIBRE CPL.
2	* 0650076	DICHTUNG	PACKING	JOINT
3	0233036	SCHLAUCHKLEMME 10/16	HOSE WIRE CLAMP 10/16	COLLIER DE SERRAGE 10/16
4		SIEHE BLATT 04 MAGNETVENTIL	SEE PAGE 04 SOLENOID VALVE	VOIR PAGE 04 ELECTRO VANNE
5		SIEHE BLATT 10 DOSIERGERÄTE	SEE PAGE 10 DOSING UNITS	VOIR PAGE 10 DOSEURS
6	9605930	SCHLAUCHKLEMME 8,5-9,5	HOSE WIRE CLAMP 8,5-9,5	COLLIER DE SERRAGE 8,5-9,5
7		SIEHE BLATT 08 EINBAUBOILER	SEE PAGE 08 INCORPORATED BOILER	VOIR PAGE 08 SURCHAUFFEUR INCORPORE
8		SIEHE BLATT 08 EINBAUBOILER	SEE PAGE 08 INCORPORATED BOILER	VOIR PAGE 08 SURCHAUFFEUR INCORPORE
9	9607418	FEDERBANDSCHELLE Ø21	HOSE CLAMP TAPE Ø21	RUBAN COLLIER DE SERRAGE Ø21
10	9609462	FEDERBANDSCHELLE Ø17	HOSE CLAMP TAPE Ø17	RUBAN COLLIER DE SERRAGE Ø17
11	8000609	WASSERLEITBLECH	WATER GUIDING SHEET	TOLE DE DEVIATION D'EAU

25.02 TÜRGEWICHTSAUSGLEICH

25.02 DOOR COUNTERWEIGHT

25.02 EQUILIBRAGE DE POIDS DE PORTE



TA25_2.doc
21.03.2006/BP

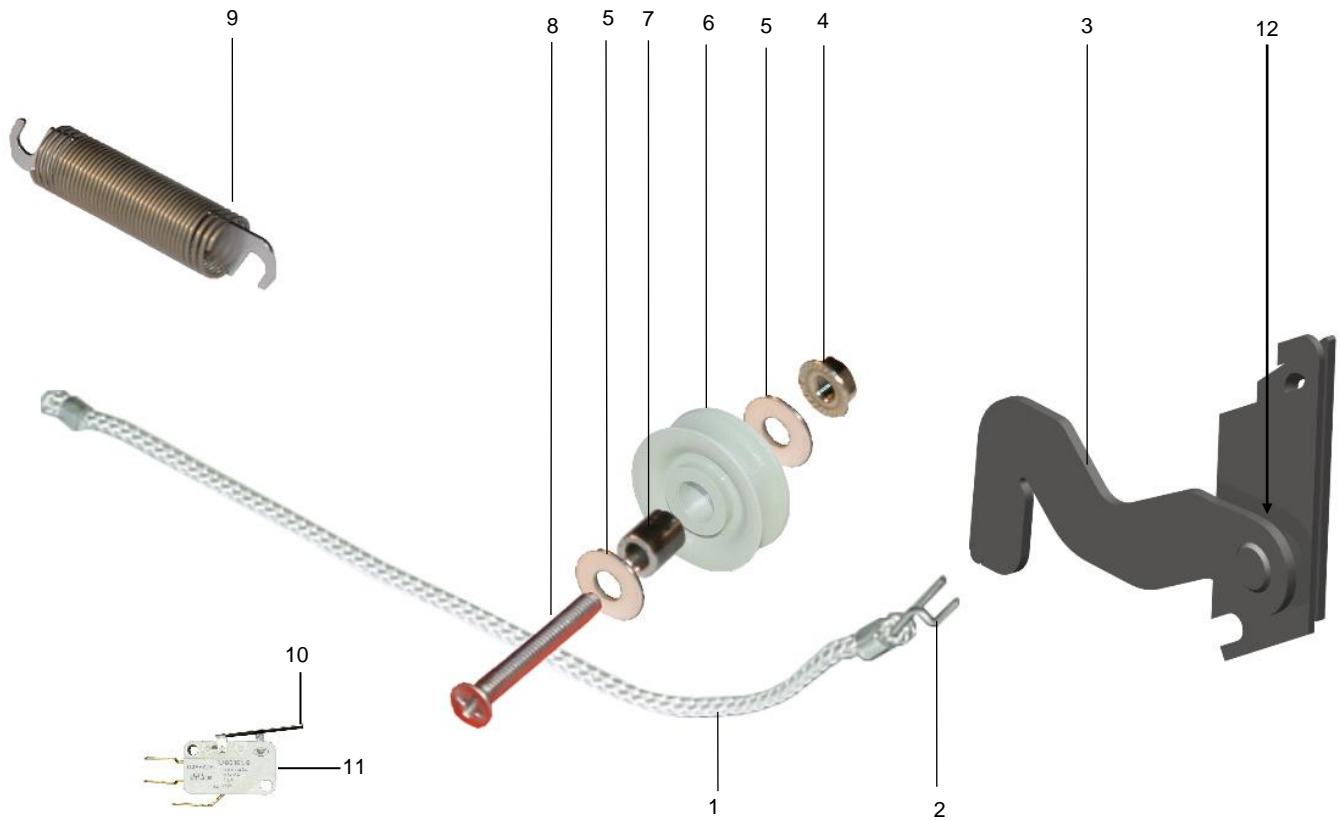

POS	IDENT. NR. IDENT. NO.	BEZEICHNUNG	DESIGNATION	DESIGNATION
1	V 0435151	SEIL	ROPE	CORDE
2	* 0435150	SEILHAKEN	ROPE HOOK	CROCHET
3	9613801-03	TÜRSCHARNIER LINKS KPL.	DOORHINGE LEFT CPL.	PORTE A CHARNIERE GAUCHE CPL.
3	9613801-04	TÜRSCHARNIER RECHTS KPL.	DOORHINGE RIGHT CPL.	PORTE A CHARNIERE DROIT CPL.
4	0337001	MUTTER M5	NUT M5	ECROU M5
5	0340020	SCHEIBE	DISK	DISQUE
6	* 9600964	SEILROLLE	ROPE ROLLER	ROULEAU POUR CORDE
7	9520736	LAGERRING	BUSHING RING	BAGUE DE PALIER
8	0306121	SCHRAUBE M5X20	SCREW M5X20	VIS M5X20
9	V 9521764	ZUGFEDER KPL.	TENSION SPRING CPL.	RESSORT DE TENSION CPL.
10	* 0122106	HEBEL FÜR MIKROSCHALTER	LEVER FOR SENSITIVE SWITCH	LEVIER POUR MICRORUPTEUR
11	* 0122103	MIKROSCHALTER	SWITCH	INTERRUPTEUR
12	V 9511585	O-RING	O-RING	BAGUE EN FORME "O"

Das Programm auf einen Blick

1

**Spülautomaten mit stationärem
Waschverfahren**
Geschirr- und Gläserpülautomaten;
Topf- und Behälterspülautomaten;
Salat- und Gemüsewaschautomaten

2

Spülautomaten mit Durchlaufsystem
Geschirrspülautomaten mit Bandtransport-,
Korbtransport- oder Umlaufsystem

3

Speziälpülanlagen
Vollautomatische Spülanlagen für Geschirr,
Tablets und Besteck; Flight-Catering-
Anlagen; Industripülautomaten; Trolley-,
Behälter- und Transportwagenspülanlagen

4

Förderanlagen
Tablett- und Geschirrtransportbänder,
Geschirrsortier- und Stapleinrichtungen

5

Speisereste-Behandlungsanlagen
Maschinen und Anlagen zur Aufbereitung
von Speiseresten für eine umweltgerechte
Entsorgung

6

Großkücheneinrichtungen
Geräte und Mobiliar für Relais- und Stations-
küchen; Transportwagen; Tablett- und Teller-
stapler; Tische, Schränke und Regale aus
Edelstahl; diverse Organisationsmittel

7

**Sanitäreinrichtungen für Krankenhäuser
und Heime**
Reinigungs- und Desinfektionsautomaten
für Steckbecken und andere Pflegegeschirre;
Pflegekombinationen; Komplettausstattung
für Unreine Arbeitsräume

Our product range

**Automatic dishwashing machines
with fixed washing system**

**Belt conveyor and rack transport
machines**
for continuous throughput operations

Special purpose warewashing solutions
such as semi and fully automatic systems,
designed for the catering industry in general

Conveying systems
for vertical and horizontal transport of trays
and dishes

Food waste treatment systems
Water conditioning appliances

Central wash-up equipment
Tables, cabinets, tray and plate stackers

**Sanitary appliances for healthcare
establishments**
Automatic cleaning and disinfection
appliances for bedpans and other care
utensils

Notre gamme de production

**Lave-vaisselle à procéder de lavage
stationnaire**
Automates de lavage

**Lave-vaisselle automatiques à passage
continu**
Lave-vaisselle automatiques à convoyeur et
à transport de paniers

Lave-vaisselle spéciaux
Installations de lavage entièrement
automatiques et semi-automatiques,
lave-vaisselle industriels

Installations de transport
pour le transport vertical et horizontal de
plateaux

**Installations de traitement de déchets
alimentaires**
ainsi que des installations de traitement
d'eau

Installations pour grandes cuisines
Tables, empileurs de plateaux et d'assiettes

**Installations sanitaires pour hôpitaux et
maisons de soins**
Automates de nettoyage et de désinfection,
combinés de soins



MEIKO Maschinenbau GmbH & Co. KG
Englerstr. 3 · 77652 Offenburg · Germany
Tel. + 49 (0)781/203-0
Fax +49 (0)781/203-1274
e-mail: info@meiko.de · www.meiko.de



FOODSERVICE EQUIPMENT SPARES LTD

UNIT 4 SANDBROOK PARK, SANDBROOK WAY, ROCHDALE, OL11 1RY

01706 353 633

SALES@FOODSERVICESPARES.COM



WWW.FOODSERVICESPARES.COM