



TECHNICAL **DIAGRAMS**



C1300E 3

01706 353 633

[WWW.FOODSERVICESPARES.COM](http://WWW.FOODSERVICESPARES.COM)

PARTI DI RICAMBIO  
PIECES DETACHEES  
SPARE PARTS  
ERSATZTEILE  
LISTA DE RECAMBIOS

# C 1000 E BT

# C 1300 E BT

9/02

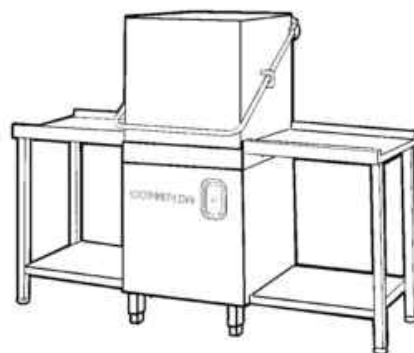

10 - 2003 S. AG.

- 1 Hood/Tank
- 2 Tank
- 3 Handle
- 4 Wash/Rinse column
- 5 Wash arm
- 6 Pump
- 7 Control panel
- 8 Rinse aid injector

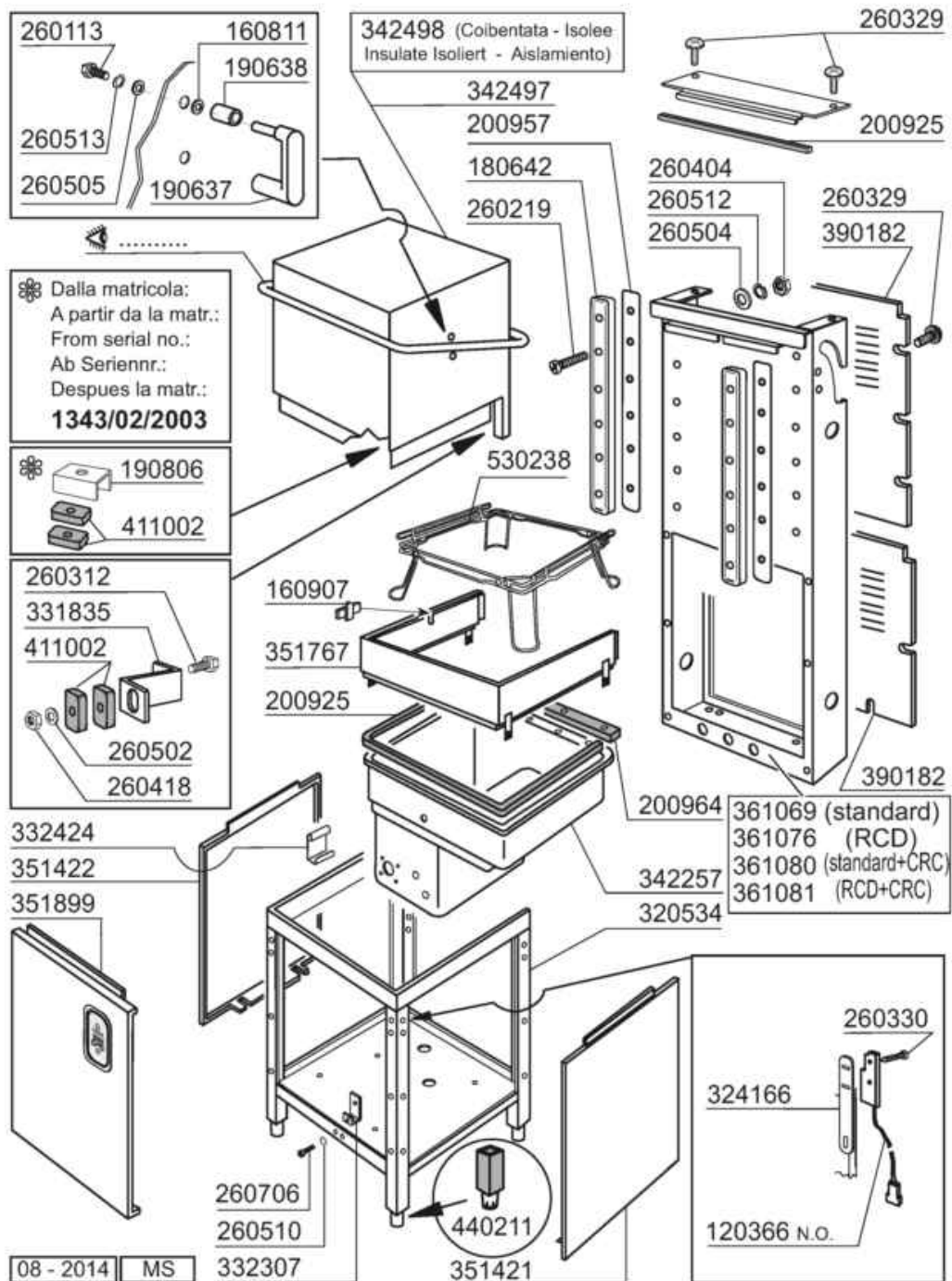

Code	Description	Price (€)
120366	MAGN.SENSOR	
160811	WASHER F2 18X8.5X1 ALGOF	
160907	CONNECTION FOR TABLES C95-155	
180642	GUIDE	
190637	GUIDE FOR DOOR "C"	
190638	ROLLER FOR "C" DOOR GUIDE	
190806	MAGNET HOUSING	
200925	GASKET	
200957	GASKET	
200964	GASKET 618X14 SP.2	
260113	STAINL.ST.TE SCREW 8X20 A2 UNI	
260219	STAINL.ST TCP SCREW 6X35 A2 UN	
260312	SCREW TSP 4X16	
260329		
260330		
260404	STAINLESS STEEL NUTS D6 UNI 55	
260418	SELF-LOCKING NUT M4	
260502	S/S FLAT WASHER D.4	
260504	ST/ST FLAT WASHER D6	
260505	STAINL.STEEL FLAT WASHER D8	
260510	GROWER WASHER D.4	
260512	ST/ST GROWER WASHER D6	
260513	GROWER WASHER D8	
260706	SCREW 3,9X13 S/S	
320534	LOWER FRAME	
324166	MICROSWITCH BRACKET	
331835	BRACKET F.MAGNET C165	
332307	BRACKET	
332424	HOSE SUPPORT	
342257	TANK	
342497	HOOD	
342498	INSULATED HOOD	
351421	LEFT PANEL	
351422	RIGHT PANEL	
351767	FRONT PANEL	
351899	FRONT PANEL C1000-1300	
361069	BACK FRAME	
361076	FRAME	
361080		
361081		
411002	PERMANENT MAGNET 24X12	
440211	LEGS 40x40x1	
530238	RACK SUPPORT C-SERIES	

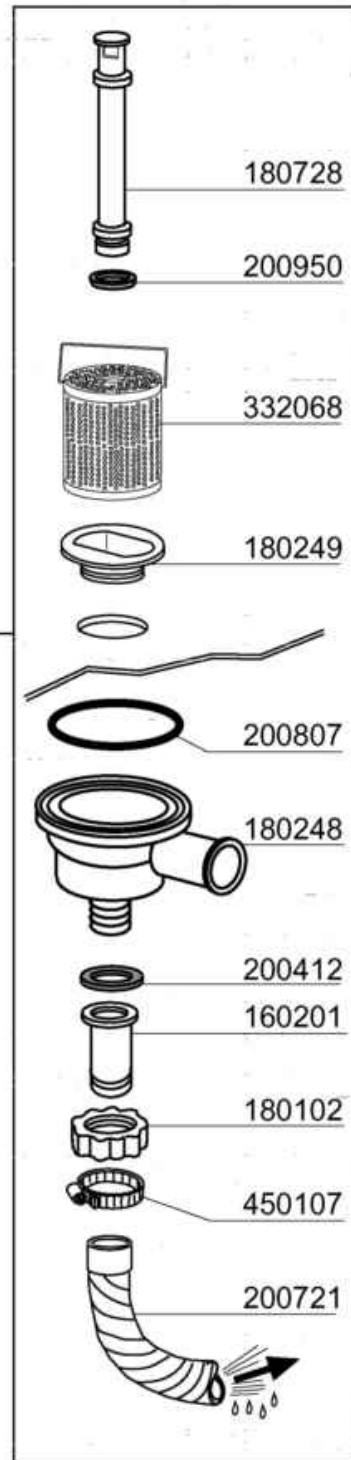
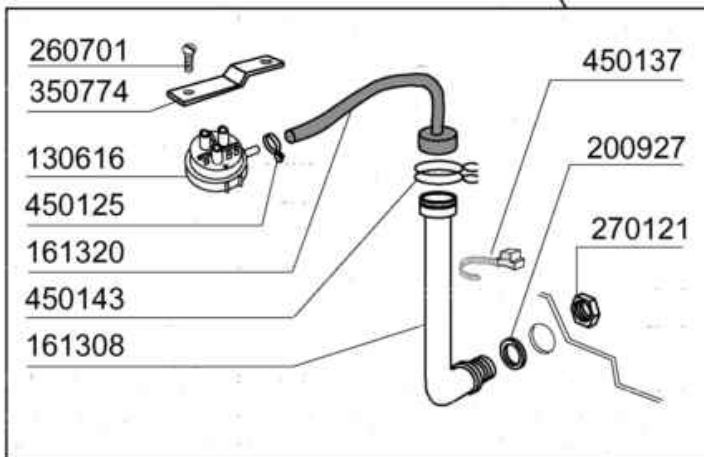
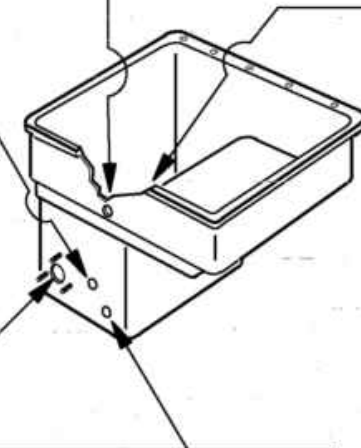
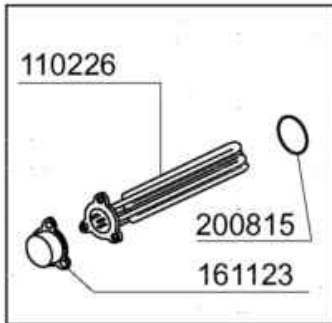
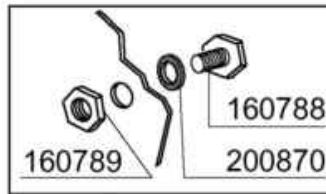
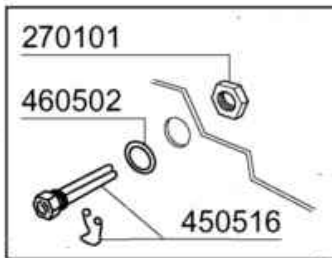
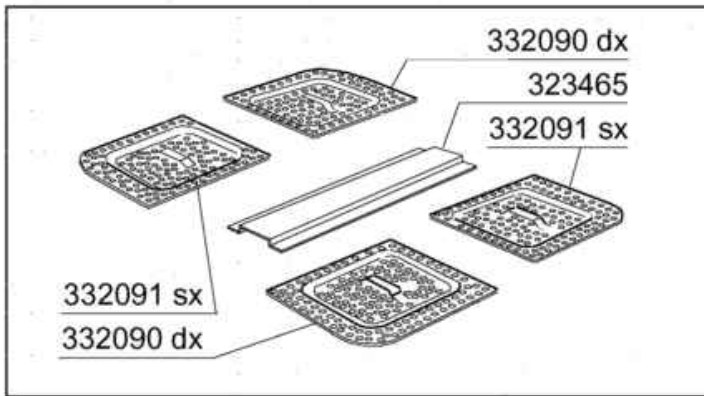

02 - 2004 S. AG.

Code	Description	Price (€)
110226	HEAT. ELEMENT 3000W 230/400V	
130616	PRESSURE SWITCH 190/80 FOR C95	
160201	ELBOW F.TANK INLET MOPLN	
160788	PLUG	
160789	NUT	
161123	HEAT.ELEMENT COVER H42 SNL	
161308	AIR CHAMBER C95-155	
161320	HOSE FOR AIR CHAMBER	
180102	DRAIN PIPE NUT 1"1/2 F45-55	
180248	SUCTION TANK	
180249	NUT	
180728	OVERFLOW PIPE	
200412	GASKET DRAIN 11/2" 45X33X3	
200721	DRAIN HOSE 28X35 3MT.	
200807	O-RING 3,53 X 110,72	
200815	O-RING F. HEAT. ELEM.	
200870	GASKET 18X10X2	
200927	GASKET FOR AIR TRAP	
200950	VITON GASKET	
260701	SCREW 3,5X9,5	
270101	HEXAGON LOCK NUT 1/2"	
270121	NUT FOR AIR TRAP	
323465	STRAINERS SUPPORT	
332068	STRAINER	
332090	RIGHT STRAINER	
332091	LEFT STRAINER	
350774	BRACKET	
450107	CLAMP FE ZN 38-50 H=12,2	
450125	ELASTIC CLAMP D. 10,4X9,8	
450137	COLLAR CONNECTION WITH BASE 31	
450143	CLAMP D.39,7 X 37,7	
450516	THERMOSTAT SHIELD FOR 2 TERMOS	
460502	GASKET 30X21X2	

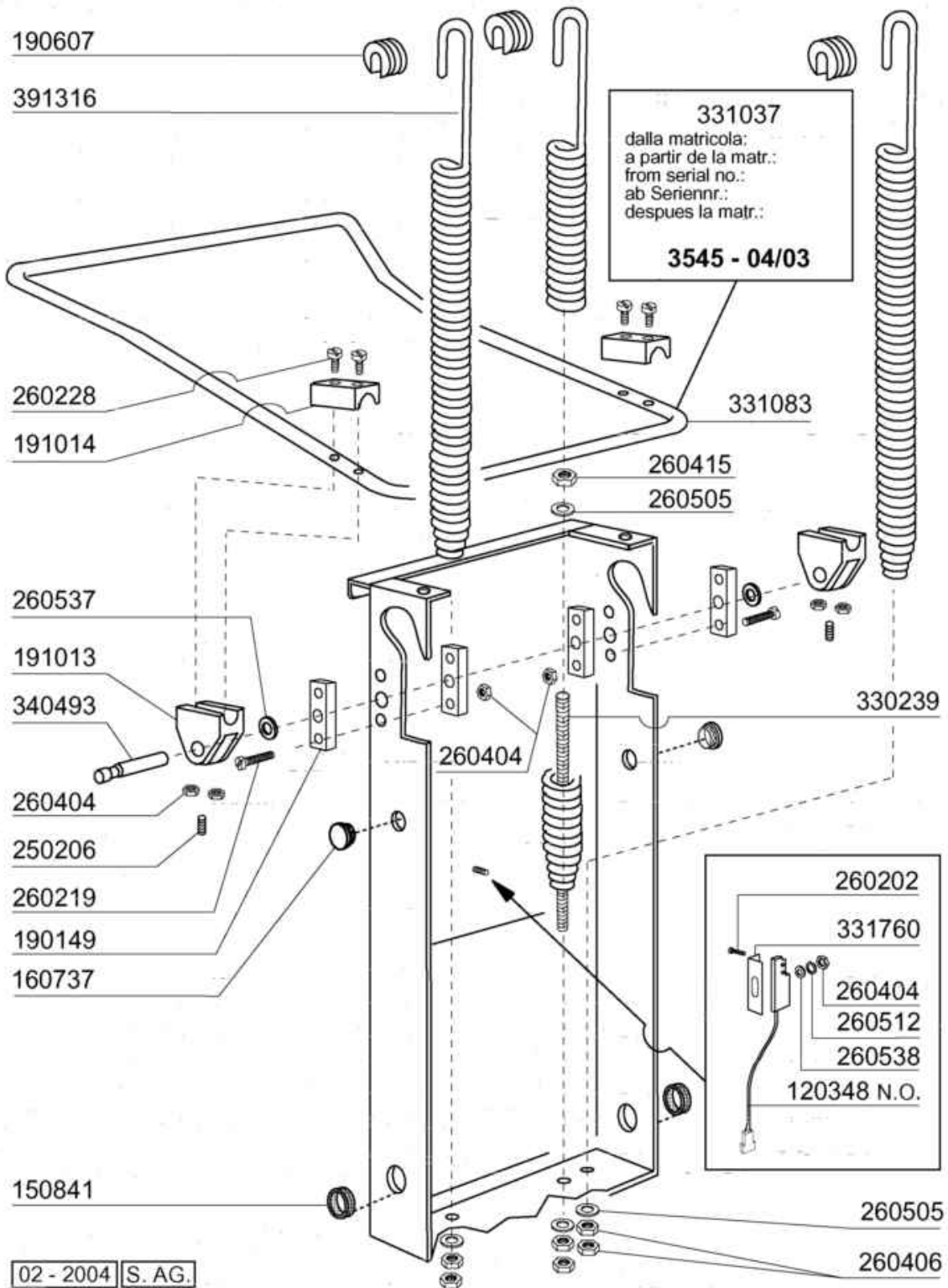

Code	Description	Price (€)
120348	MAGN. SWITCH (N.O.)	
150841	CABLE HOLDER	
160737	PLUG HEYCO D.34,9	
190149	REINFORCEMENT FOR HANDLE SUPP.	
190607	HANDLE BUSH C30-70	
191013	HINGE F. SUPPORT C30-C70	
191014	FLANGE F. HANDLE C30-70	
250206	GRUB SCREW D.6	
260202	SCREW TCP 3X16	
260219	STAINL.ST TCP SCREW 6X35 A2 UN	
260228	STAINL.ST SPECIAL SCREW 6X42 3	
260404	STAINLESS STEEL NUTS D6 UNI 55	
260406	NUT 8MA	
260415	STAINLESS STEEL SELF-LOCKING N	
260505	STAINL.STEEL FLAT WASHER D8	
260512	ST/ST GROWER WASHER D6	
260537	STAINL.STEEL FLAT WASHER D13X2	
260538	WASHER 18X6X1,5 ST/ST	
330239	ROD	
331037	HANDLE C95-155-165 ISOLATED	
331083	HANDLE	
331760	BRACKET	
340493	PIN F. HINGE C30	
391316	SPRING FOR HANDLE C85/140-G75	

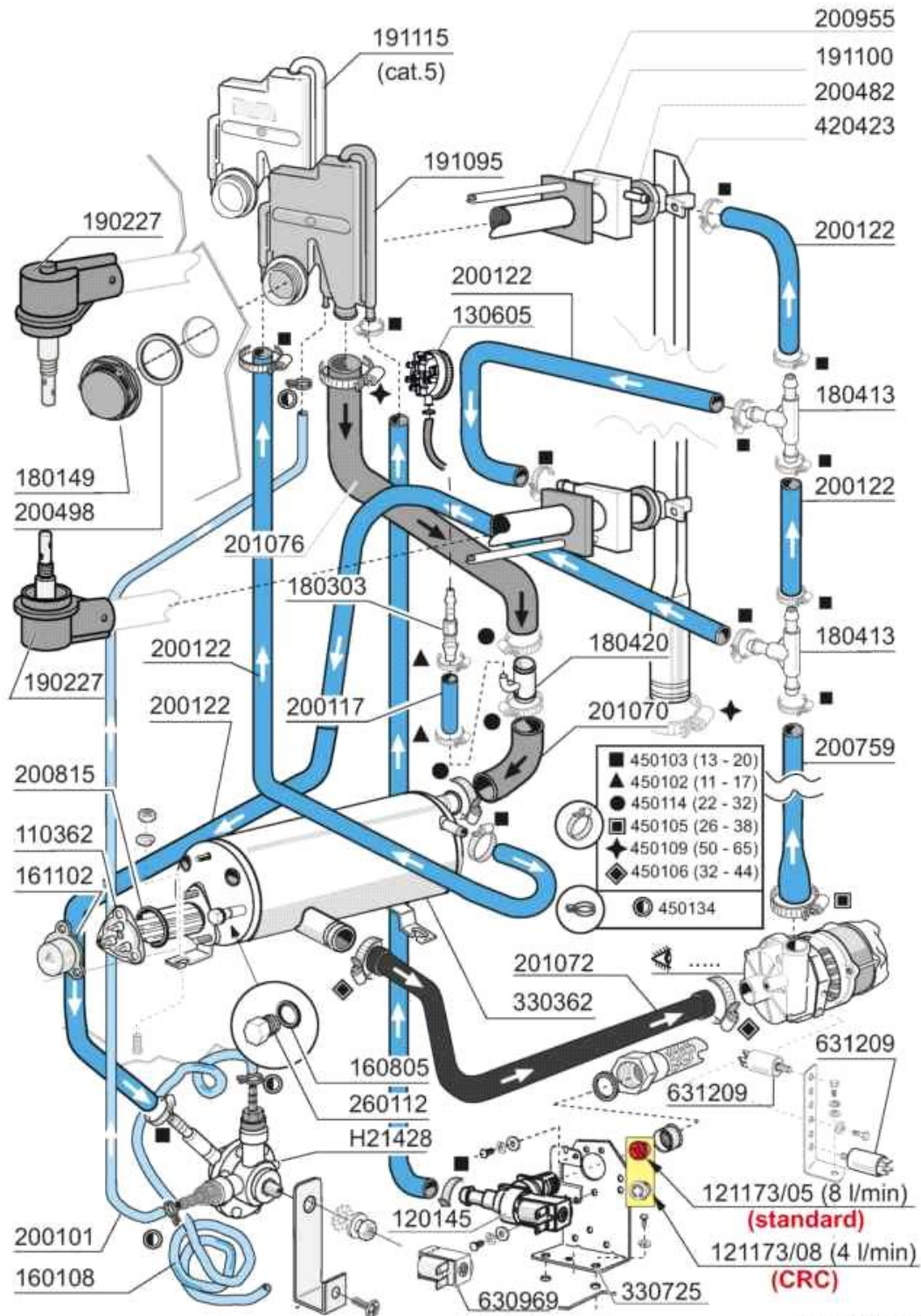

09-2015 MS

Code	Description	Price (€)
110362	HEAT.ELEMENT 9000W 220/380V	
120145	SOLENOID VALVE 12 LT 1 WAY	
121173/05	FLUX REGULATOR 8 l/min RED	
121173/08	FLUX REGULATOR 4,5l/min WHITE	
130605	PRESSURE SWITCH 50-30 1 LEVEL	
160108	INJECT.INLET HOSE D.8X5	
160805	GASKET D.8	
161102	ELEMENT COVER MOPL. H50 (HIGH)	
180149	PLASTIC NUT	
180303	DOUBLE HOSE BARB	
180413	TEE NIPPLE D.11,5 - RINSE ASSE	
180420	TEE-NIPPLE	
190227	ARM SUPPORT	
191095	CONTAINER FOR BREAK TANK	
191100	RINSE COLLECTOR C-LC	
191115	BREAK TANK	
200101	RUBBER TUBE 25X35	
200117	RUBBER HOSE 7X16	
200122	HOSE 11X19	
200482	GASKET 60X54 RAMP C140	
200498	GASKET	
200759	DELIVERY HOSE FOR ECORINSE AC-	
200815	O-RING F. HEAT. ELEM.	
200955	GASKET	
201070	HOSE	
201072	HOSE	
201076	HOSE	
260112	STAINLESS STEEL TE-SCREW 8X16	
330362	BOOSTER FOR BREAK TANK	
330725	STANDARD BRACKET F.SOLEN.VALV	
420423	WASH RAMP C/LC	
450102	CLAMP FE ZN 11-17 H=9	
450103	CLAMP FE ZN. 13-20 H=9	
450105	CLAMP FE ZN. 26-38 H=12,2	
450106	CLAMP FE ZN 32-44 H=12,2	
450109	CLAMP 50-65	
450114	CLAMP FE ZN.22-32 H=12,2	
450134	ELASTIC HOSE CLIP D.9,3/8,8	
630969	COIL S4216 220/50HZ	
631209	ANTI-NOISE FILTER	
H21428	RINSE AID INJECTOR	

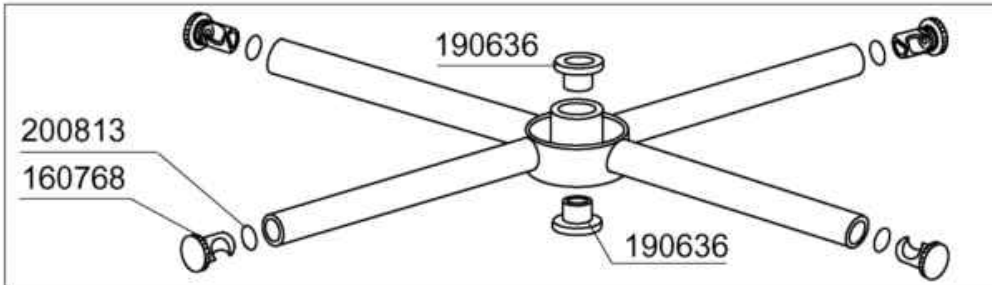
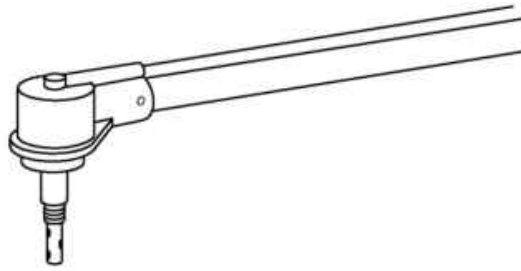

**420535**

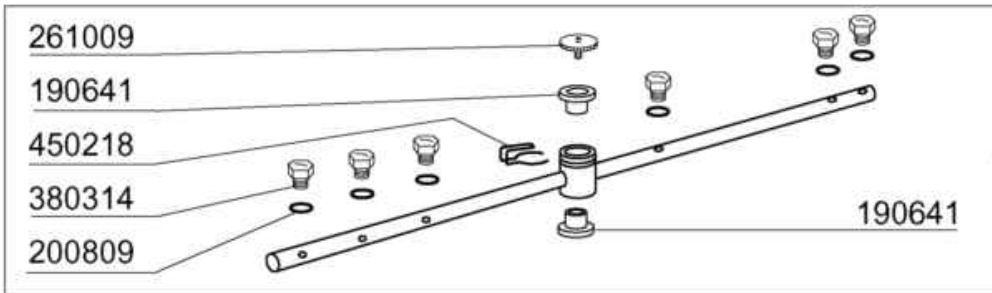
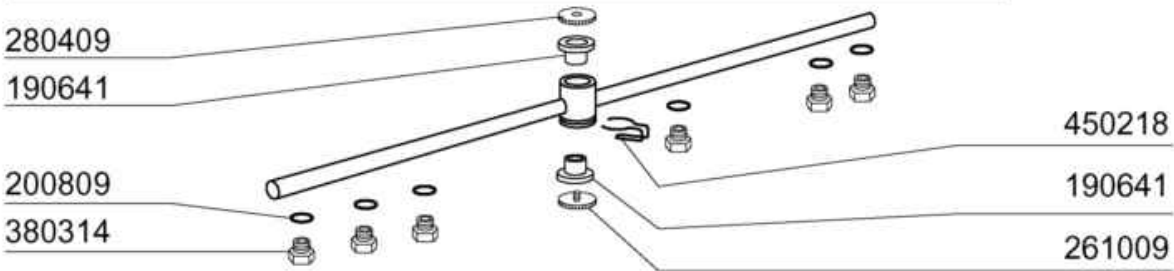

**430316**

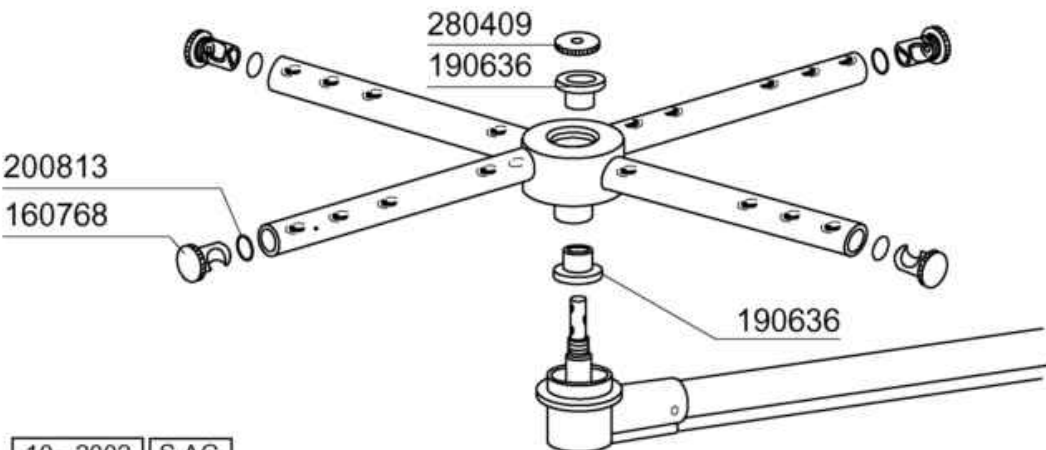

10 - 2002 | S.A.G.

Code	Description	Price (€)
160768	PLUG FOR "C95-155" WASH ARM	
190636	BUSH FOR C95-155-165 WASH ARM	
190641	BUSH FOR C95-155-165 RINSE ARM	
200809	OR GASKET 1,78X8,73X12,29	
200813	OR GASKET 2,21X16,36X20,78	
261009	RETAIN.SCREW FOR WASH-RINSE AR	
280409	RETAIN.LOCK NUT CENTR.CROSS C1	
380314	RINSE JETS 801/HR	
420535	WASH ARM C1300-C155	
430316	RINSE ARM FOR C95-C155-C165	
450218	SPRING F.RINSE ARM RETAIN.SCRE	

441139

630329

630250

344000

631692 (50 HZ) kW 1,1

631709 (60 HZ) kW 1,1

631692 (50 HZ) kW 1,5

631709 (60 HZ) kW 1,5

630528

631210 30  $\mu$ F

630251 only for single phase

630137

630426

STANDARD	100796	400 V	50Hz	kW 1,5
	100798	400 V	50Hz	kW 1,1
SPECIAL	100800	230 V	50Hz	kW 1,1
	100804	400 V	60Hz	kW 1,1
	100806	440 V	60Hz	kW 1,5
	100808	400 V	60Hz	kW 1,5
	100809	440 V	60Hz	kW 1,1
	100821	230 V	50Hz	kW 1,5
-	-	-	-	-
-	-	-	-	-

Risciacquo - Rincage - Rinse - Aclarado - Nachspülpumpe

630538

INOX-STAINLESS  
STEEL-STAHL-ACIER

631704 (50 hz)

631711 (60 hz)

630249

631216 6,3  $\mu$ F

630533

631698

PLASTICA-PLASTIC  
KUNSTSTOFF-PLASTIQUE

630136

630427

STANDARD	100802	230 V	50Hz	kW 0.29
	100889	440 V	60Hz	kW 0.26
SPECIAL	100897	230 V	60Hz	kW 0.33
	-	-	-	-

11- 2013 | M.S.A.

Code	Description	Price (€)
100796	PUMP 2HP 400/3/50HZ LGB	
100798	PUMP 1,5HP LGB	
100800	PUMP HP1,5-230/50	
100802	PUMP HP 0,3 230V-50HZ	
100804	PUMP 1,5HP 220/3/60	
100806	PUMP 2HP 440V/3 60HZ	
100808	PUMP HP 2 380/3/60	
100809	PUMP HP 1,5 440/3/60	
100821	PUMP HP 2 230/1/50	
100889	PUMP HP 0,3 440V-60HZ	
100897	PUMP HP 0,3 230V-60HZ	
344000	PUMP SUPPORT	
441139	VIBRATION-DAMPING FEET 25X20X6	
630136	PUMP VOLUTE LGB ZF131DX	
630137	PUMP VOLUTE LGB ZF800DX	
630249	PUMP FLANGE ZF131 DX	
630250	BACK PLATE PUMP ZF650/800	
630251	FAN HOUSING ZF650/800	
630329	PUMP FAN IMPELLOR ZF650/800	
630426	GASKET LGB ZF800	
630427	O-RING FOR PUMP ZF131DX	
630528	SEAL LGB ZF800 2HP	
630533	PUMP SEALS WASH PUMP ZF131DX	
630538	SEAL LGBZF131DX	
631210	CAPACITOR 30MF 450V	
631216	CAPACITOR 6.3 MF 450V	
631692	IMPELLER PUMP ZF650/800	
631698	PUMP IMPELLER ZF131DX	
631704	PUMP IMPELLER ZF131DX	
631709	PUMP IMPELLER ZF800 60HZ	
631711	IMPELLER LGB ZF131DX 60HZ D.66	

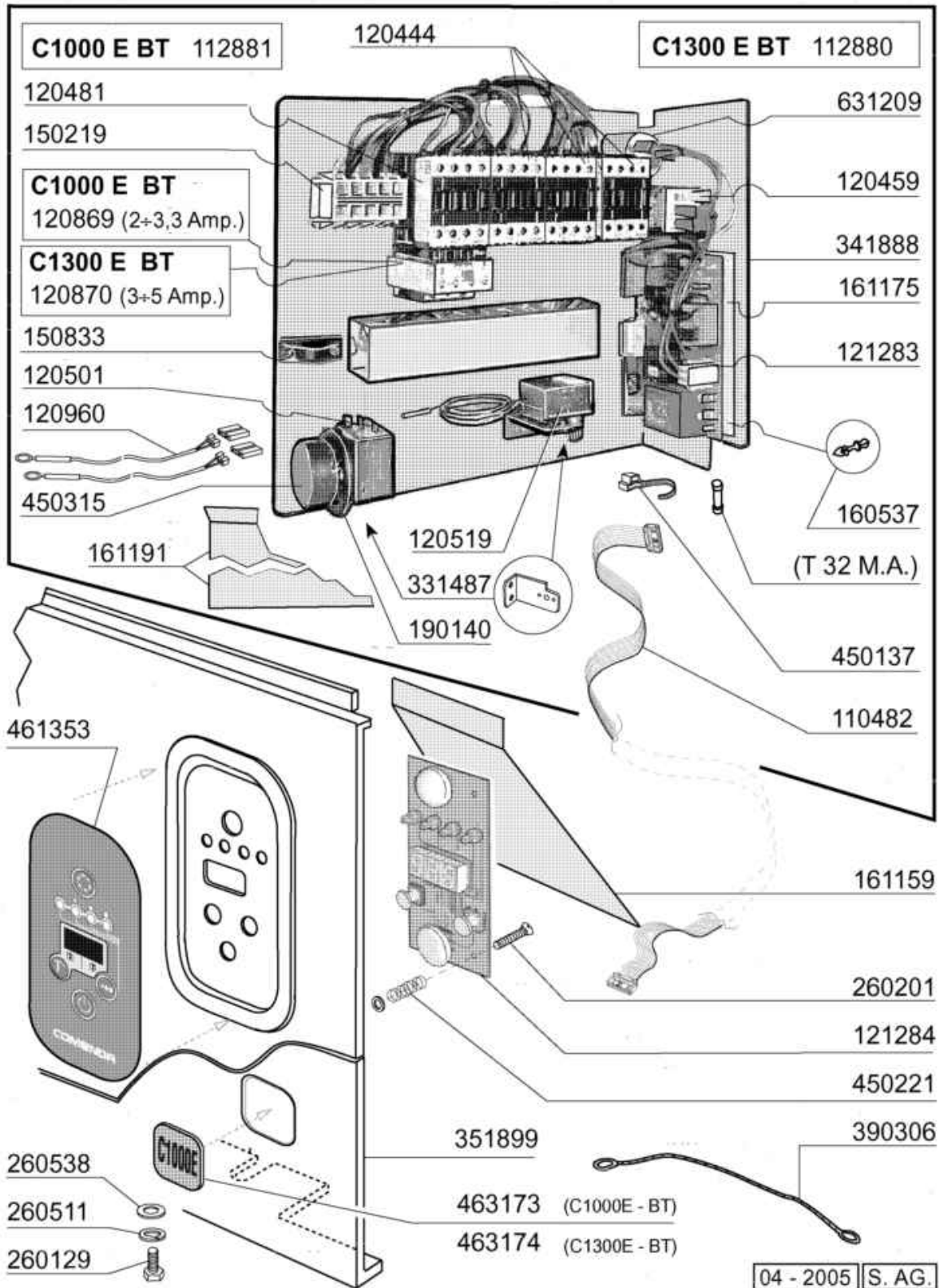

Code	Description	Price (€)
110482	CABLE FOR PCB FC-C-GE	
112880	WIRING C1300E BT	
112881	WIRING C1000E BT	
120444	CONTACTOR 9A 220V 50HZ	
120459	AUXIL.RELE 16A 220V	
120481	CONTACTOR 9A-230V 50/60HZ	
120501	THERMOSTAT 30/90°C	
120519	SAFETY THERMOSTAT 95-125°	
120869	OVERLOAD RELAY 2/3,3	
120870	OVERLOAD RELAY 3/5	
120960	PROBE C-G	
121283	ELECTRONIC PANEL "C-GE"	
121284	ELECTRONIC CONTROL PANEL C-GE	
150219	TERMINAL BLOCK 5P MMQ165VD26	
150833	CABLE HOLDER BC/BR	
160537	ELECTRONIC CARD SPACER	
161159	PROTECT. COMMANDS SWITCHBOARD	
161175	PROTECTION	
161191	CONTROL BOX COVER	
190140	BUTTON HOLDER BR-BC-FC	
260129	SCREW TE M 5X20	
260201	SCREW TCP 3X10	
260511	GROWER WASHER D.5	
260538	WASHER 18X6X1,5 ST/ST	
331487	BRACKET FOR 1 THERMOSTAT	
341888	CONTROL BOX SUPPORT	
351899	FRONT PANEL C1000-1300	
390306	CABLE	
450137	COLLAR CONNECTION WITH BASE 31	
450221	SPRING FOR ELECTRONIC TIMER	
450315	KNOB F. THERMOSTAT 90°	
461353	PLATE C-GE ELECTRONIC	
631209	ANTI-NOISE FILTER	

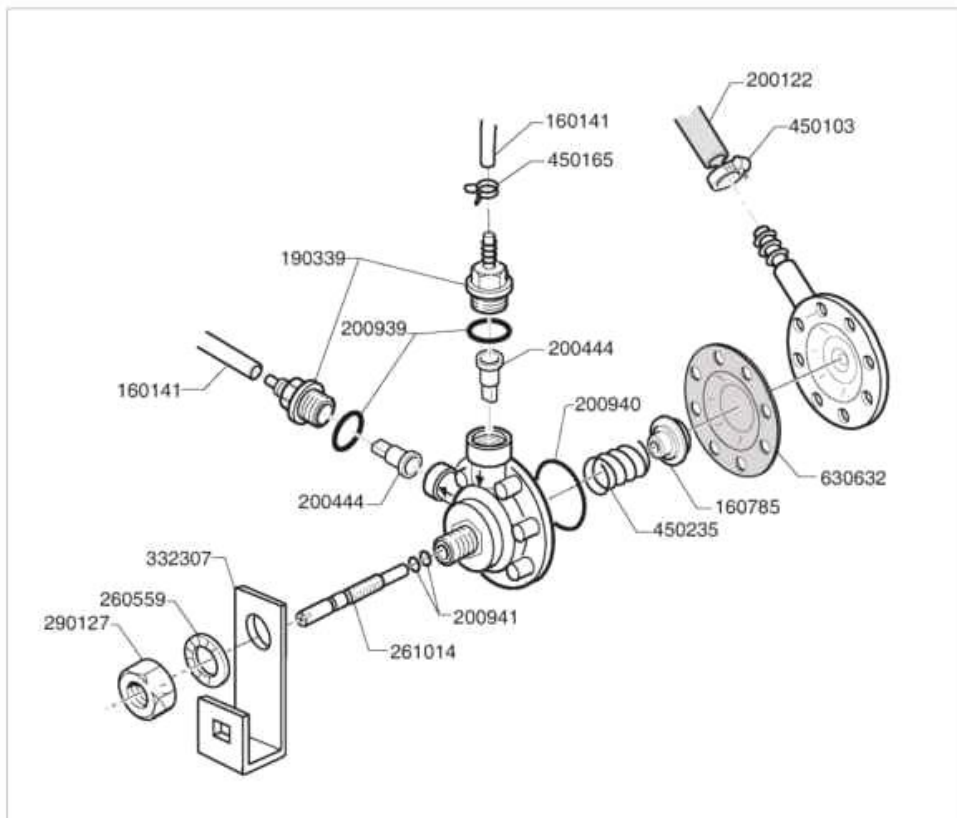

Code	Description	Price (€)
160141	HOSE 4X7	
160785	GUIDE FOR SPRING RINSE AID INJ	
190339	RINSE AID INJECTOR CONNECTION	
200122	HOSE 11X19	
200444	SUCTION VALVE RINSE INJECTOR	
200939	OR GASKET	
200940	GASKET	
200941	OR GASKET	
260559	FLAT WASH A2D.12 DIN6798	
261014	SCREW	
290127	DISPENSER FIXING NUT	
332307	BRACKET	
450103	CLAMP FE ZN. 13-20 H=9	
450165	ELASTIC HOSE CLIP 7,3-7,8	
450235	SPRING RINSE AID INJECTOR	
620879	RINSE AID INJECTOR	
630632	DIAPHRAGM RINSE INJECTOR HVD	



FOODSERVICE EQUIPMENT SPARES LTD

UNIT 4 SANDBROOK PARK, SANDBROOK WAY, ROCHDALE, OL11 1RY

01706 353 633

SALES@FOODSERVICESPARES.COM



WWW.FOODSERVICESPARES.COM