

OPERATOR'S MANUAL



Model 0736 Counter Top Heat Treatment Soft Serve Freezer

Original Operating Instructions

087827-M

02/08/2018 (Original Publication)
(Updated 12/4/2018)

Complete this page for quick reference when service is required:

Taylor Distributor: _____

Address: _____

Phone: _____

Service: _____

Parts: _____

Date of Installation: _____

Information found on the data label:

Model Number: _____

Serial Number: _____

Electrical Specs: Voltage _____ Cycle _____

 Phase _____

Maximum Fuse Size: _____ A

Minimum Wire Ampacity: _____ A

***Note:** Continuing research results in steady improvements; therefore, information in this manual is subject to change without notice.*

***Note:** Only instructions originating from the factory or its authorized translation representative(s) are considered to be the original set of instructions.*

© 2018 Taylor Company (Updated 12/4/2018)
087827-M

Any unauthorized reproduction, disclosure, or distribution of copies by any person of any portion of this work may be a violation of Copyright Law of the United States of America and other countries, could result in the awarding of Statutory Damages of up to \$250,000 (17 USC 504) for infringement, and may result in further civil and criminal penalties.

All rights reserved.



Taylor Company
750 N. Blackhawk Blvd.
Rockton, IL 61072

Table of Contents

Section 1: To the Installer

Installer Safety	1-1
Site Preparation	1-1
Air-Cooled Machines.....	1-2
Water Connections.....	1-2
Electrical Connections.....	1-2
Electrical Hookup Installation	1-3
Beater Rotation	1-3
Refrigerant	1-4
Indications for Decommissioning	1-4

Section 2: To the Operator

Operator Information.....	2-1
Working Limits.....	2-1
Compressor Warranty Disclaimer	2-2

Section 3: Safety

Installer Information.....	3-1
To Operate Safely	3-1
Machine Warning Labels.....	3-2

Section 4: Operator Parts Identification

Main View.....	4-1
Single Spout Door Assembly	4-3
Mix Pump Assembly.....	4-4
Tune Up Kit	4-5
Brush Assembly	4-6

Section 5: User Interface

Symbol Definitions	5-2
LCD Display	5-2
Indicator Icons on the Display and Buttons.....	5-2
Operating Screen Description	5-3
Main Power Switch OFF	5-3
Main Power Switch ON	5-4
Heat Cycle.....	5-4
Freezer Locks	5-4
Hard Lock.....	5-4
Soft Lock	5-5

Manager's Menu.....	5-5
Manager Menu Options.....	5-5
Servings Counter.....	5-6
Set Clock.....	5-6
Auto Heat Time.....	5-6
Auto Start Time.....	5-6
Auto Standby Time.....	5-7
Event History.....	5-7
Lockout History.....	5-8
Heat Cycle Summary.....	5-8
Heat Cycle Data.....	5-8
System Information.....	5-9
Language.....	5-9

Section 6: Operating Procedures

Assembly.....	6-1
Beater Assembly.....	6-1
Freezer Door Assembly.....	6-2
Mix Pump Assembly.....	6-5
Feed Tube Assembly.....	6-7
Sanitizing.....	6-8
Priming.....	6-8
Daily Closing Procedures.....	6-9
Daily Opening Procedures.....	6-10
Manual Brush Cleaning.....	6-10
Draining Product From the Barrel.....	6-11
Rinsing.....	6-11
Hopper Cleaning.....	6-11
Disassembly.....	6-11
Brush Cleaning.....	6-12
Adjustments.....	6-12
Consistency Adjustment.....	6-12
Hopper Temperature Adjustment in AUTO Mode.....	6-13
Hopper Agitation Adjustment in AUTO Mode.....	6-13
Hopper Temperature Adjustment in STANDBY Mode.....	6-14
Hopper Agitation Adjustment in STANDBY Mode.....	6-14

Section 7: Operator Checklist

During Cleaning and Sanitizing.....	7-1
Troubleshooting Bacterial Count.....	7-1
Regular Maintenance Checks.....	7-1
Winter Storage	7-2

Section 8: Troubleshooting Guide

Section 9: Parts Replacement Schedule

Maintenance Intervals.....	9-1
----------------------------	-----

Section 10: Limited Warranty on Machines

Section 11: Limited Warranty on Parts

The following information has been included in the manual as safety and regulatory guidelines. For complete installation instructions, please see the Installation Checklist.

Installer Safety



IMPORTANT! In all areas of the world, the machine should be installed in accordance with existing local codes. Please contact your local authorities if you have any questions.

Care should be taken to ensure that all basic safety practices are followed during the installation and servicing activities related to the installation and service of Taylor machines.

- Only authorized Taylor service personnel should perform installation and repairs on the machine.
- Authorized service personnel should consult OSHA Standard 29CFR1910.147 or the applicable code of the local area for the industry standards on lockout/tagout procedures before beginning any installation or repairs.
- Authorized service personnel must ensure that the proper personal protective equipment (PPE) is available and worn when required during installation and service.
- Authorized service personnel must remove all metal jewelry, rings, and watches before working on electrical equipment.



DANGER! The main power supply(s) to the machine must be disconnected prior to performing any repairs. Failure to follow this instruction may result in personal injury or death from electrical shock or hazardous moving parts, as well as poor performance or damage to the machine.

Note: All repairs must be performed by a Taylor service technician.



WARNING! This machine has many sharp

edges that can cause severe injuries.

Site Preparation

Review the area where the machine will be installed before uncrating the machine. Make sure that all possible hazards to the user and the machine have been addressed.



WARNING! Only install this machine in a location where its use and maintenance is restricted to trained personnel. Failure to comply may result in personal injury.

For Indoor Use Only: This machine is designed to operate indoors under normal ambient temperatures of 70°F to 75°F (21°C to 24°C). The freezer has successfully performed in high ambient temperatures of 104°F (40°C) at reduced capacities.

IP Code = 23



WARNING! This machine must **NOT** be installed in an area where a water jet or hose can be used. Never use a water jet or hose to rinse or clean this machine. Using a water jet or hose on or around this machine may result in the electrocution of the user or damage to the machine.



CAUTION! This machine must be installed on a level surface to avoid the hazard of tipping. Extreme care should be taken in moving this machine for any reason. Two or more persons are required to safely move this machine. Failure to comply may result in personal injury or machine damage.

Uncrate the machine and inspect it for damage. Report any damage to your Taylor distributor.

Air-Cooled Machines

Do not obstruct air intake and discharge openings; a minimum 6 in. (152 mm) air space is required on both sides and 1 in. (25 mm) at rear. This will allow for adequate air flow across the condenser. Failure to allow adequate clearance can reduce the refrigeration capacity of the freezer and possibly cause permanent damage to the compressor.

Water Connections

Water-Cooled Machines Only

An adequate cold water supply must be provided with a hand shutoff valve. On the underside rear of the base pan, two 3/8 in. I.P.S. water connections for inlet and outlet have been provided for easy hookup. Water lines connected to the machine should have 1/2 in. (13 mm) inside diameters. (Flexible lines are recommended, if local codes permit.) Depending on local water conditions, it may be advisable to install a water strainer to prevent foreign substances from clogging the automatic water valve. There will be only one water-in and one water-out connection. **Do not** install a hand shutoff valve on the water-out line! Water should always flow in this order: first, through the automatic water valve; second, through the condenser; and third, through the outlet fitting to an **open trap drain**.



IMPORTANT! A backflow prevention device is required on the incoming water connection side. Please see the applicable national, state, and local codes for determining the proper configuration.

Electrical Connections

Each machine requires one power supply for each data label on the machine. Check the data label(s) on the freezer for branch circuit overcurrent protection or fuse, circuit ampacity, and other electrical specifications. Refer to the wiring diagram provided inside the electrical box for proper power connections.

In the United States, this machine is intended to be installed in accordance with the National Electrical Code (NEC) ANSI/NFPA 70-1987. The purpose of the NEC code is the practical safeguarding of persons and property from hazards arising from the use of electricity. This code contains provisions considered necessary for safety. Compliance therewith and proper maintenance will result in an installation essentially free from hazard!

In all other areas of the world, this machine should be installed in accordance with the existing local codes. Please contact your local authorities.



FOLLOW YOUR LOCAL ELECTRICAL CODES.



WARNING! This machine must be properly grounded! Failure to do so can result in severe personal injury from electrical shock!



IMPORTANT! This machine is provided with an equipotential grounding lug that is to be properly attached to the rear of the frame by the authorized installer. The installation location is marked by the equipotential bonding symbol (5021 of IEC 60417-1) on the removable panel and the machine's frame.

**NOTICE!**

- Stationary machines which are not equipped with a power cord and a plug or another device to disconnect the machine from the power source must have an all-pole disconnecting device with a contact gap of at least 0.125 in. (3 mm) installed in the external installation.
- Machines that are permanently connected to fixed wiring and for which leakage currents may exceed 10 mA, particularly when disconnected or not used for long periods, or during initial installation, shall have protective devices to protect against the leakage of current, such as a GFI, installed by the authorized personnel to the local codes.
- Supply cords used with this machine shall be oil-resistant, sheathed flexible cable not lighter than ordinary polychloroprene or other equivalent synthetic elastomer-sheathed cord (code designation 60245 IEC 57) installed with the proper cord anchorage to relieve conductors from strain, including twisting, at the terminals and protect the insulation of the conductors from abrasion.
- If the supply cord is damaged, it must be replaced by the manufacturer, service agent, or a similarly qualified person, in order to avoid a hazard.

**CAUTION!** Avoid injury.

- Make sure the machine is electrically disconnected.
- Remove the appropriate panel and locate the small electrical box at the base of the machine.
- Remove the factory-installed cord and strain relief bushing.
- Route incoming permanent wiring through the 7/8 in. (22 mm) hole in base pan.
- Connect two power supply leads. Attach ground (earth) wire to the grounding lug inside the electrical box.
- Make sure the machine is properly grounded before applying power.

1

Beater Rotation

NOTICE! Beater rotation must be clockwise as viewed looking into the freezing cylinder.

The following procedures should be performed by a Taylor service technician.

To correct rotation on a three-phase machine, interchange any two incoming power supply lines at freezer main terminal block only.

To correct rotation on a single-phase machine, change the leads inside the beater motor. (Follow the diagram printed on the motor.)

Electrical connections are made directly to the terminal block in the splice boxes that are mounted mid-level on the frame channel on the sides of the freezer.

Refrigerant



CAUTION! This machine contains fluorinated greenhouse gases (F-Gas) to provide refrigeration using a hermetically sealed circuit or within foam insulation.

This machine's type of gas, quantity, Global Warming Potential (GWP), and CO₂ tonnes equivalent information is recorded on the unit's data-label. The refrigerant used is generally considered non-toxic and non-flammable. However any gas under pressure is potentially hazardous and must be handled with caution.

NEVER fill any refrigerant cylinder completely with liquid. Filling the cylinder to approximately 80% will allow for normal expansion.



CAUTION! Use only approved refrigerant listed on the machine's data-label or authorized through a manufacturer's technical bulletin. The use of any other refrigerant may expose users and operators to unexpected safety hazards.



WARNING! Refrigerant liquid sprayed onto the skin may cause serious damage to tissue. Keep eyes and skin protected. If refrigerant burns should occur, flush the area immediately with cold water. If burns are severe, apply ice packs and contact a physician immediately.



NOTICE! Taylor reminds technicians to be aware of government laws regarding refrigerant recovery, recycling, and reclaiming systems. If you have any questions regarding these laws, please contact the factory service department.

Indications for Decommissioning



IMPORTANT! If the crossed-out waste container symbol is affixed to this product, it signifies that this product is compliant with the EU Directive as well as other similar legislation in effect after August 13, 2005. Therefore, it must be collected separately after its use is completed, and cannot be disposed as unsorted municipal waste.

The user is responsible for delivering the product to the appropriate collection facility, as specified by your local code.

Note: Even packaging materials (crates or boxes) must be divided by type and disposed of in compliance with Standards in force in the Country where it is used when the machine is decommissioned.

Operator Information

The Model 0736 soft serve freezer has been carefully engineered and manufactured to give you dependable operation.

This machine is suitable for food mixtures heat treatment, storage and batch, according to use allowed by law.

This machine, when properly operated and cared for, will produce a consistent quality product. Like all mechanical products, it will require cleaning and maintenance. A minimum amount of care and attention is necessary if the operating procedures outlined in this manual are followed closely.



IMPORTANT! This manual should be read before operating or performing any maintenance on your machine.

The Model 0736 will **not** eventually compensate and correct for any errors during the setup or filling operations. Thus, the initial assembly and priming procedures are of extreme importance. It is strongly recommended that personnel responsible for the machine's operation, both assembly and disassembly, go through these procedures together in order to be properly trained and to prevent misunderstandings.

In the event you should require technical assistance, please contact your local authorized Taylor Distributor.

Note: Your Taylor warranty is valid only if the parts are authorized Taylor parts purchased from the local authorized Taylor distributor, and only if all required service work is provided by a Taylor service technician. Taylor reserves the right to deny warranty claims on machines or parts if unapproved parts or incorrect refrigerant were installed in the machine, system modifications were performed beyond factory recommendations, or it is determined that the failure was caused by abuse, misuse, neglect, or failure to follow all operating instructions. For full details of your Taylor warranty, please see Limited Warranty on Machines on page 10-1 and Limited Warranty on Parts on page 11-1.

Note: Constant research results in steady improvements; therefore, information in this manual is subject to change without notice



IMPORTANT! If the crossed-out waste container symbol is affixed to this product, it signifies that this product is compliant with the EU Directive as well as other similar legislation in effect after August 13, 2005. Therefore, it must be collected separately after its use is completed, and cannot be disposed as unsorted municipal waste.

The user is responsible for delivering the product to the appropriate collection facility, as specified by your local code.

For additional information regarding applicable local laws, please contact the municipal facility and/or local distributor.

Working Limits

Do not use the machine with inconstant power supplies or +/- 10% beyond the value indicated on the plate or with the power cable damaged;

Do not use the machine in explosive atmospheres;

Do not wash the machine with high-pressure water jets or with harmful substances;

Do not expose the machine to excessive heat or humidity.

Do not use unbalanced mixtures and/or amounts which do not comply with the specifications carried on the packs.

Usage not expressly indicated in this manual is to be considered improper and therefore must be strictly avoided.

The manufacturer will not be held liable for direct or indirect harm to persons or animals or damage to objects caused by improper use of the machine.

Compressor Warranty Disclaimer

The refrigeration compressor on this machine is warranted for the term stated in the Limited Warranty section in this manual. However, due to the Montreal Protocol and the U.S. Clean Air Act Amendments of 1990, many new refrigerants are being tested and developed, thus seeking their way into the service industry.

Some of these new refrigerants are being advertised as drop-in replacements for numerous applications. It should be noted that in the event of ordinary service to this machine's refrigeration system, **only the refrigerant specified on the affixed data label should be used.**

The unauthorized use of alternate refrigerants will void your Taylor compressor warranty. It is the machine owner's responsibility to make this fact known to any technician he employs.

It should also be noted that Taylor does not warrant the refrigerant used in its products. For example, if the refrigerant is lost during the course of ordinary service to this machine, Taylor has no obligation to either supply or provide its replacement either at billable or unbillable terms. Taylor does have the obligation to recommend a suitable replacement if the original refrigerant is banned, obsolete, or no longer available during the five-year warranty of the compressor.

Taylor will continue to monitor the industry and test new alternates as they are being developed. Should a new alternate prove, through our testing, that it would be accepted as a drop-in replacement, then the above disclaimer would become null and void. To find out the current status of an alternate refrigerant as it relates to your compressor warranty, call the local Taylor Distributor or the Taylor Factory. Be prepared to provide the Model/Serial Number of the machine in question.

Installer Information

We at the Taylor Company are concerned about the safety of the operator when he or she comes into contact with the freezer and its parts. Taylor has gone to extreme efforts to design and manufacture built-in safety features to protect both you and the service technician. As an example, warning labels have been attached to the machine to point out safety precautions to the operator.



DANGER! Failure to adhere to the following safety precautions may result in severe personal injury or death. Failure to comply with these warnings may also damage the machine and/or its components. Such damage may require component replacement and service repair expenses.

To Operate Safely



NOTICE! DO NOT operate the machine without reading the Operator Manual. Failure to follow this instruction may result in machine damage, poor machine performance, health hazards, or personal injury.



WARNING! Avoid injury.

- **DO NOT** allow untrained personnel to operate this machine.
- **DO NOT** put objects or fingers in the door spout.
- **DO NOT** operate the machine unless all service panels and access doors are restrained with screws.
- **DO NOT** remove the machine door or beater assembly unless the control switches are in the OFF position.

Failure to follow these instructions may result in severe personal injury from hazardous moving parts.



WARNING! This machine has many sharp edges that can cause severe injuries.

- **DO NOT** put objects or fingers in the door spout. Failure to follow this instruction may result in contaminated product or personal injury from blade contact.
- **USE EXTREME CAUTION** when removing the beater assembly. The scraper blades are very sharp and may cause injury.



IMPORTANT! Access to the service area of the machine is restricted to persons having knowledge and practical experience with the machine, in particular as far as safety and hygiene are concerned.



CAUTION! This machine must be installed on a level surface to avoid the hazard of tipping. Extreme care should be taken in moving this machine for any reason. Two or more persons are required to safely move this machine. Failure to comply may result in personal injury or machine damage.



WARNING! Avoid injury.

- **DO NOT** operate the machine unless it is properly grounded.
- **DO NOT** operate machine with larger fuses than specified on the data label.
- All repairs must be performed by an authorized Taylor service technician.
- The main power supplies to machine must be disconnected prior to performing repairs.

- **For Cord-Connected Machines:** Only authorized Taylor service technicians or licensed electricians may install a plug or replacement cord on the machine.
- Stationary machine which are not equipped with a power cord and a plug or another device to disconnect the machine from the power source must have an all-pole disconnecting device with a contact gap of at least 0.125 in. (3 mm) installed in the external installation.
- Machines that are permanently connected to fixed wiring and for which leakage currents may exceed 10 mA, particularly when disconnected or not used for long periods, or during initial installation, shall have protective devices to protect against the leakage of current, such as a GFI, installed by the authorized personnel to the local codes.
- Supply cords used with this machine shall be oil-resistant, sheathed flexible cable not lighter than ordinary polychloroprene or other equivalent synthetic elastomer-sheathed cord (code designation 60245 IEC 57) installed with the proper cord anchorage to relieve conductors from strain, including twisting, at the terminals and protect the insulation of the conductors from abrasion.
- If the supply cord is damaged, it must be replaced by the manufacturer, service agent, or a similarly qualified person, in order to avoid a hazard.

Failure to follow these instructions may result in electrocution. Contact your local Taylor distributor for service.



CAUTION! This machine is designed to maintain product temperature under 41°F (5°C). Any product being added to this machine must be below 41°F (5°C). Failure to follow this instruction may result in health hazards and poor machine performance.

Do not obstruct air intake and discharge openings: A minimum of 6 in. (152 mm) on both sides, and 0 in. (0 mm) in the rear is required. Install the skirt provided on the right side of the unit. Failure to follow this instruction may cause poor freezer performance and damage to the machine.

This freezer is designed to operate indoors under normal ambient temperatures of 70°F to 75°F (21°C to 24°C). The freezer has successfully performed in high ambient temperatures of 104°F (40°C) at reduced capacity.

Do not run the machine without product. Failure to follow this instruction can result in damage to the machine.

Noise Level: Airborne noise emission does not exceed 78 dB(A) when measured at a distance of 3.3 ft. (1.0 m) from the surface of the machine and at a height of 5.25 ft. (1.6 m) from the floor.

Machine Warning Labels

Rear Panel Warning Label

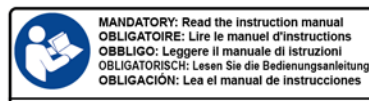

Do not operate the freezer without reading this Operator's Manual



This machine has many sharp edges that can cause severe injuries. Do not touch with hands, clean with brush/vacuum cleaner.



Only authorized Taylor service personnel should perform installation and repairs on this machine.



DANGER: High Voltage inside: danger of electrocution. Disconnect the power supply before servicing the machine.



CAUTION: Hazardous moving parts; the machine can start automatically. Do not operate with panels removed, disconnect the electrical supply before servicing the machine.



DANGER: Hot parts, risk of burns. Hot product, do not draw during heating treatment.



ATTENTION: Connect to a circuit protected by fuses or HACR type circuit breaker.



ATTENTION: Only copper conductors (Cu). Minimum section 10AWG (4mm² 1N 230V; 4mm² 3 230V; 2.5mm² 3N 400V)



ATTENTION: This equipment must be properly grounded! Failure to do so can result in severe personal injury from electrical shock!



ATTENTION: Disconnect the power supply before servicing the machine.



For decommissioning, comply with the standards in force in the country where it is used.



This machine is Rohrs 2 compliant.



Battery type CR2032 inside. For decommissioning, comply with the standards in force in the country where it is used.

p Water:	MIN	MAX	Water-cooled models
p Eau:	1 bar	3 bar	Modèles refroidis par eau
p Acqua:	1 bar	3 bar	Modelli raffreddati ad acqua
p Wasser:	100 kPa	300 kPa	Wassergekühlte Modelle
p Agua:	100 kPa	300 kPa	Modelos enfriados por agua

Water pressure limits (for water-cooled models only).

R404A	HERMETICALLY SEALED
GWP 3922	HERMETIQUEMENT SCELLÉ
HFC-125 (64%) HFC-143a (52%) HFC-134a (4%)	ERMETICAMENTE SIGILLATO
	HERMETISCH ABGEDICHTETEN
	SELLADO HERMETICAMENTE

Use only R404A refrigerant that conforms to the AHRI Standard 700 specification.

Electrical Box Warning Label

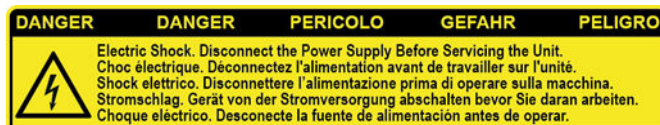

DANGER: High voltage inside, danger of electrocution. Disconnect the Power Supply Before Servicing the Unit.

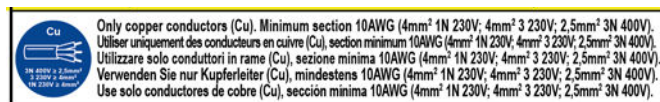

ATTENTION: Only copper conductors (Cu). Minimum section 10AWG (4mm² 1N 230V; 4mm² 3 230V; 2.5mm² 3N 400V).

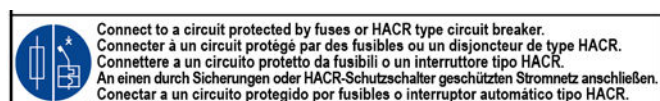

ATTENTION: Connect to a circuit protected by fuses or HACR type circuit breaker.

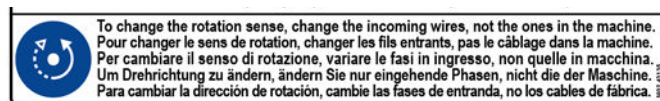

To correct rotation on a three-phase machine, interchange any two incoming power lines at the machine main terminal block only.

To correct rotation on a single-phase machine, change the leads inside the beater motor. (Follow diagram printed on motor.)

Hot Parts/Type of Glycol Warning Label



DANGER: Hot parts, risk of burns. Use only recommended Glycol with the described dilution.

Equipotential Point Label



- 3** Carry out an equipotential bonding, using the screw placed below the frame of the machine.

Lifting Point Label



Lift equipment hooking points. Position the lifting equipment only in the relevant points.

Main View

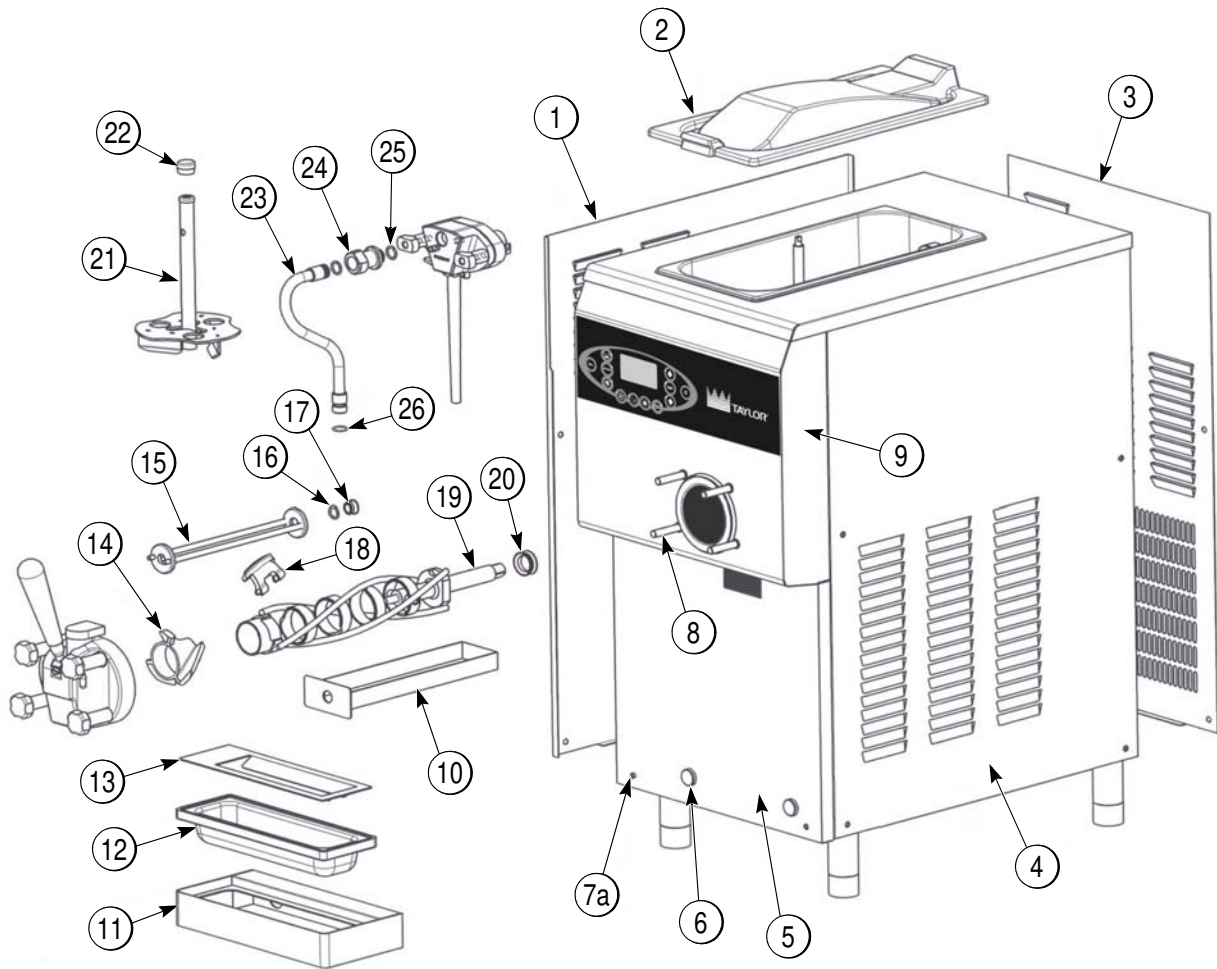

Figure 4-1

OPERATOR PARTS IDENTIFICATION

Item	Description	Part No.
1	Panel-Side-Left	087715
2	Cover-Hopper	087716
3	Panel-Rear	087717
4	Panel-Side-Right	087718
5	Panel-Front-Lower	087719
6	Fixing Screw	087720
7	Screw-Panel	087721
8	Stud-Nose Cone	087722
9	Panel-Front-Upper	087723
10	Pan-Drip	087724
11	Shelf-Tray-Drip	087725
12	Tray-Drip	087726
13	Shield-Splash	087727

Item	Description	Part No.
14	Beater-Auger	087728
15	Baffle-Door	087729
16	O-Ring-Baffle	087730
17	Bushing-Baffle	087731
18	Blade-Scraper	087732
19	Beater-2-Liter	087733
20	Seal-Beater-Drive Shaft	087734
21	Agitator-Hopper	087735
22	Cap-Agitator	087736
23	Tube-Feed	087737
24	Coupling-Feed Tube	087738
25	O-Ring-Feed Tube	087739
26	Valve-Check- Duckbill-Pump	087742

4

Single Spout Door Assembly

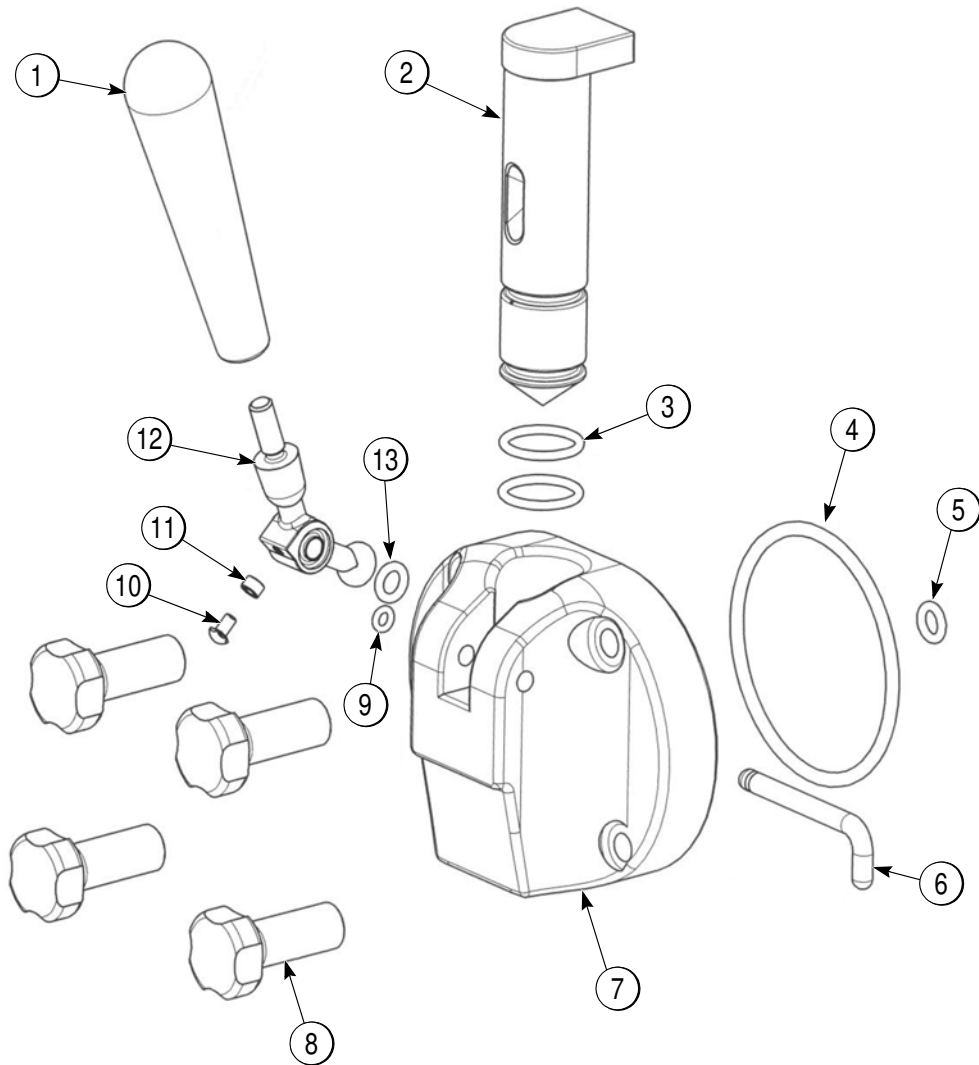

4

Figure 4-2

Item	Description	Part No.
1	Handle-Draw-Black	087740
2	Valve-Draw	087741
3	O-Ring-Draw Valve	087743
4	O-Ring-Door-Large	087744
5	O-Ring-Door-Small	087745
6	Pin-Draw Handle-SS	087746
7	Door-Freezer	087747

Item	Description	Part No
8	Nut-Stud-Door	087748
9	O-Ring-Handle Pin	087749
10	Screw-Adjustmt-Handle	087750
11	Spacer-Screw-Adjustmt	087751
12	Handle-Body	087752
13	O-Ring-Handle-Body	087753

Mix Pump Assembly

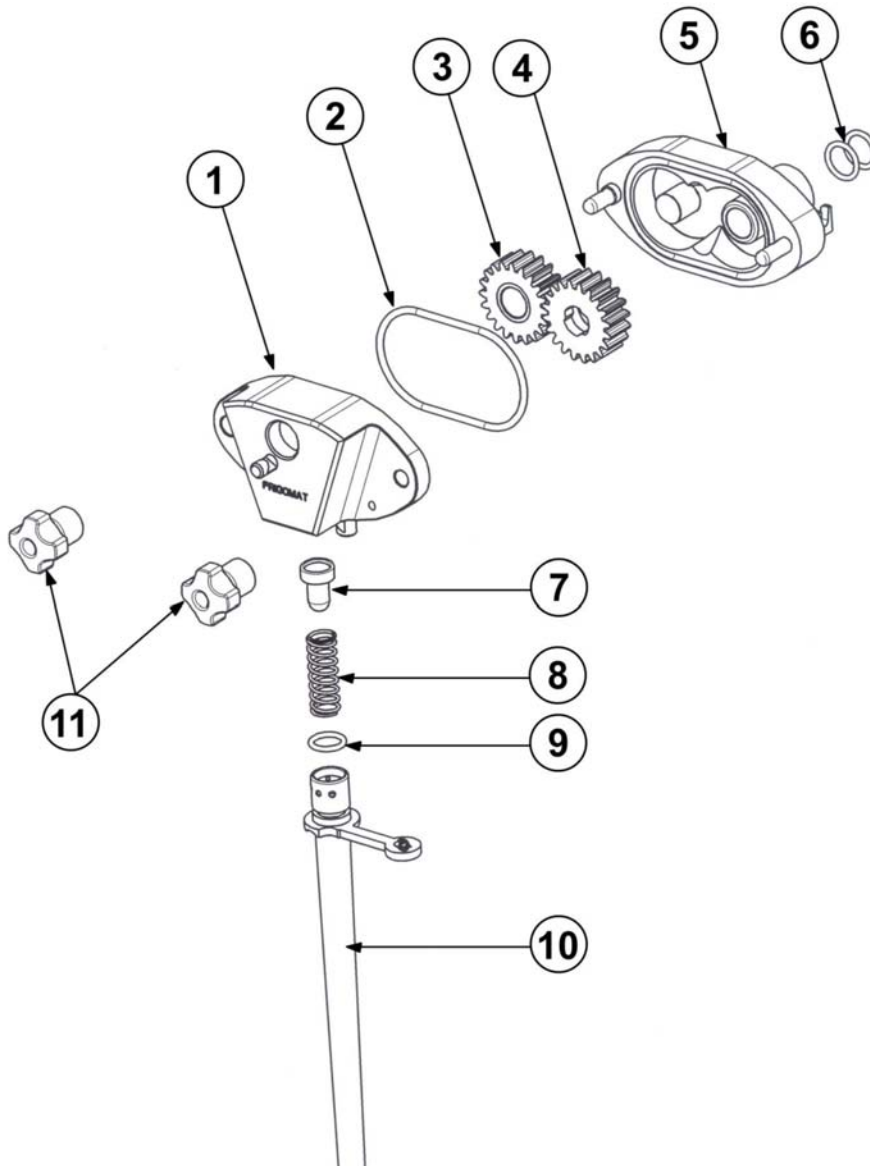

Figure 4-3

Item	Description	Part No.
1	Cover-Pump	087754
2	O-Ring Pump Body	087755
3	Gear-Driven	087756
4	Gear-Driving	087757
5	Body-Pump	087758
6	O-Ring-Pump	087759

Item	Description	Part No.
7	Valve-Pump	087765
8	Spring-Regulator	087761
9	O-Ring-Feed Tube	087739
10	Tube-Regulator	087763
11	Nut-Stud-Pump	087764

4

Tune Up Kit

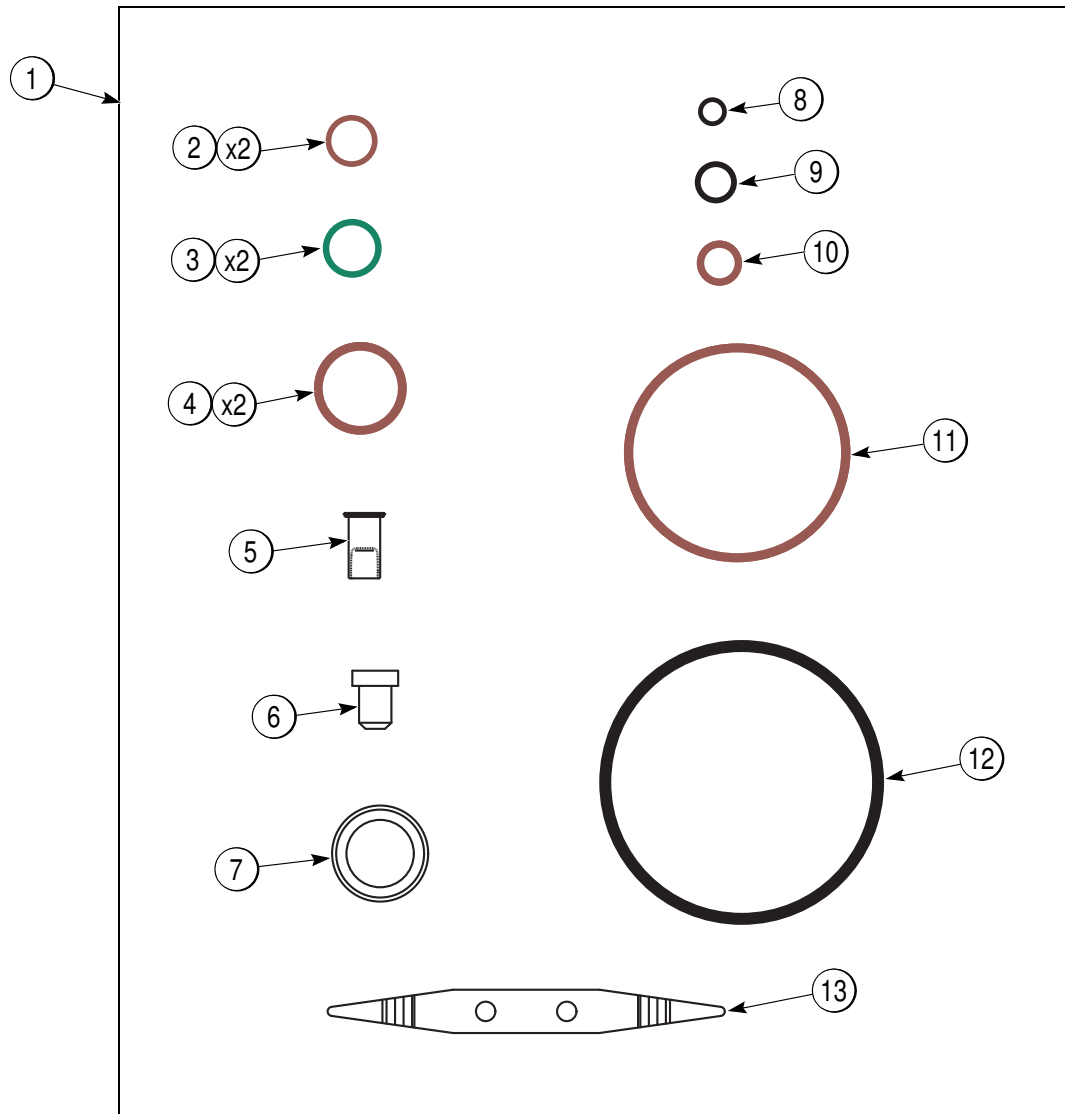

Figure 4-4

Item	Description	Part No.
1	Kit-Tune Up *0736*	087774
2	O-Ring-Feed Tube	087739
3	O-Ring-Pump	087759
4	O-Ring-Draw Valve	087743
5	Valve-Check- Duckbill-Pump	087742
6	Valve-Pump	087765
7	Seal-Beater-Drive Shaft	087734

Item	Description	Part No.
8	O-Ring-Handle-Pin	087749
9	O-Ring-Handle-Body	087753
10	O-Ring-Door-Small	087745
11	O-Ring-Pump-Body	087755
12	O-Ring-Door-Large	087744
13	Tool-O-Ring Removal	048260-F

Brush Assembly

4

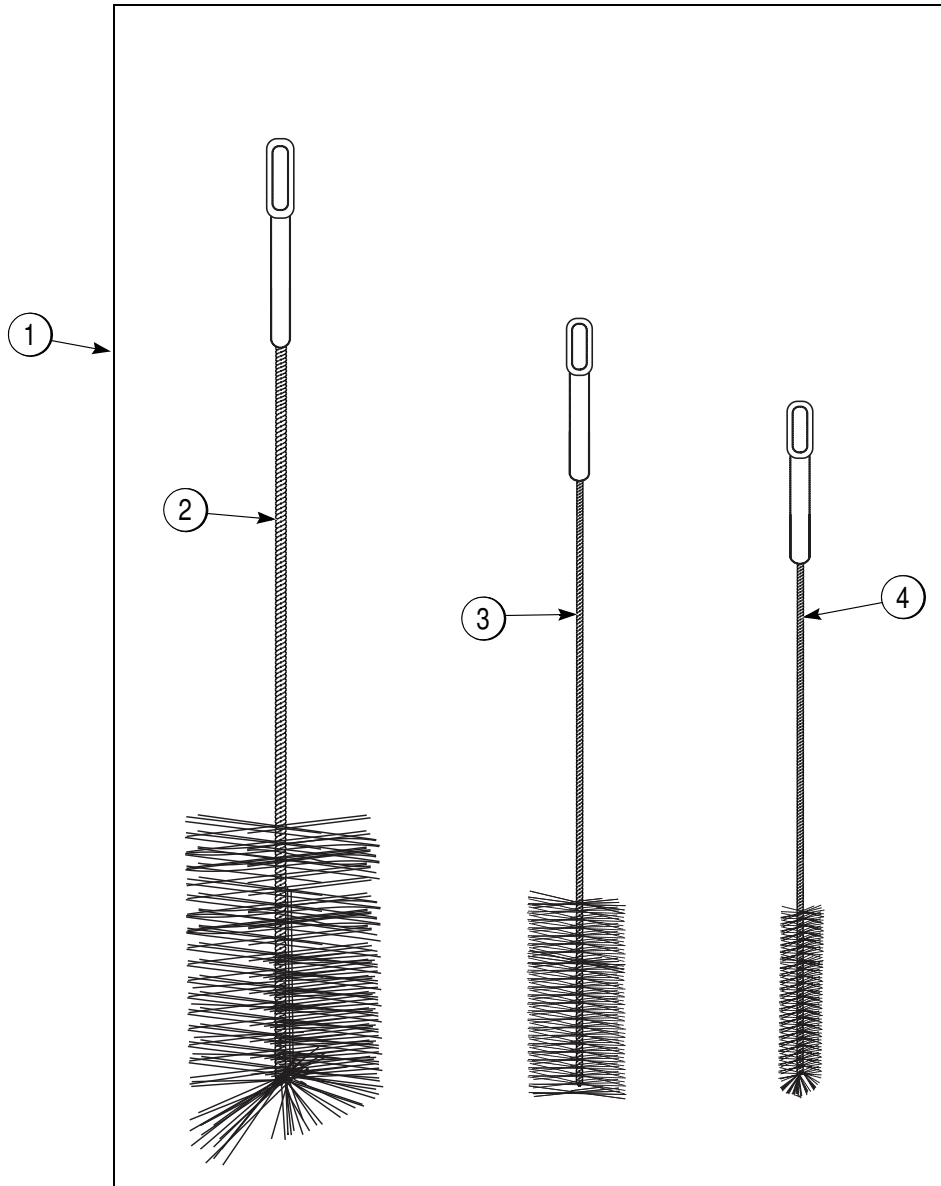

Figure 4-5

Item	Description	Part No
1	Kit-Brush *0736*	087805
2	Brush-Hopper	087806
3	Brush-Mix Inlet	087809
4	Brush-Drive Hub	087810

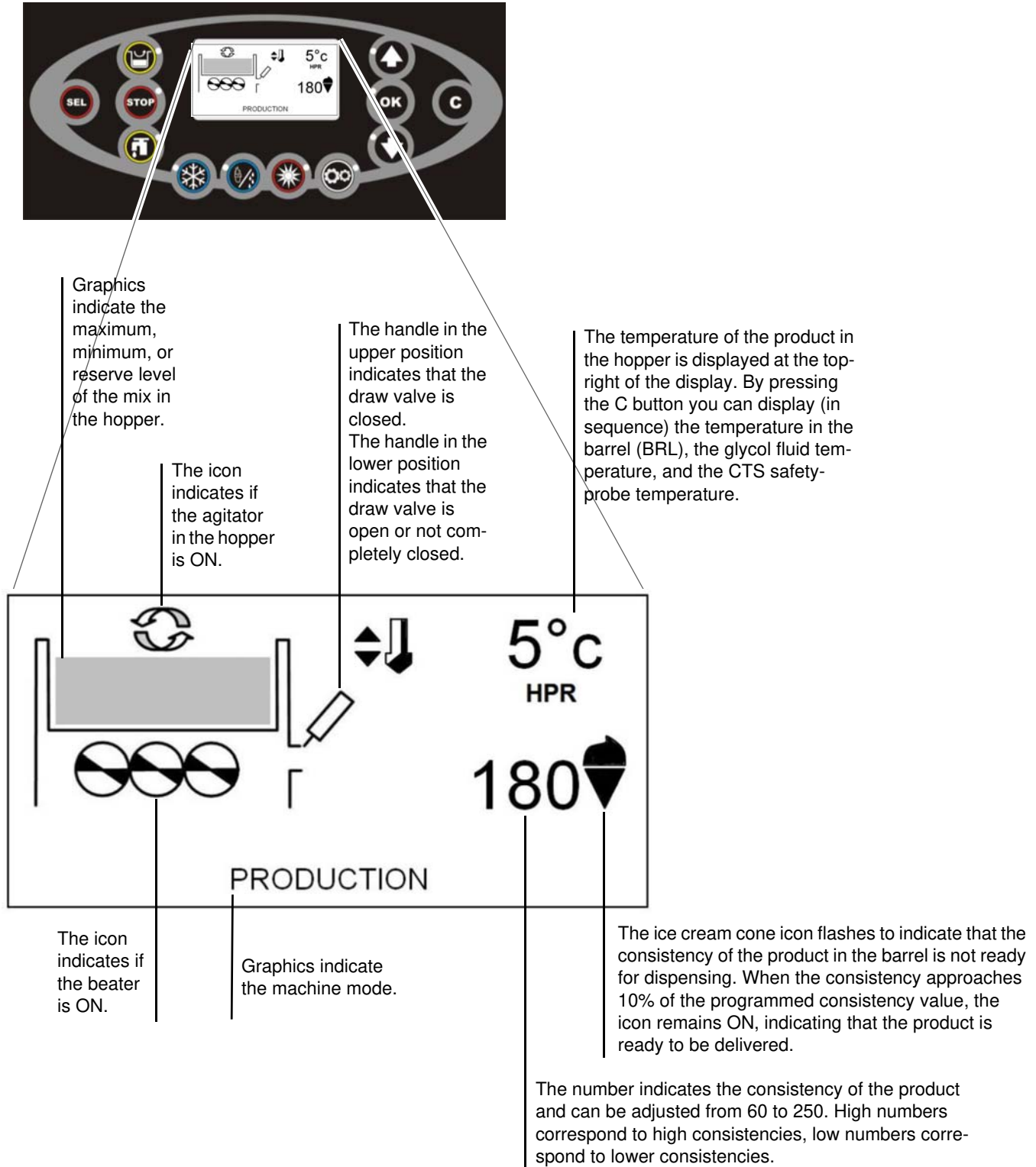

Figure 5-1

Symbol Definitions

To better communicate in the international area, symbols have replaced words on many of our operator switches, function, and fault indicators. Your Taylor machine is designed with these international symbols.

The following chart identifies the symbol definition.

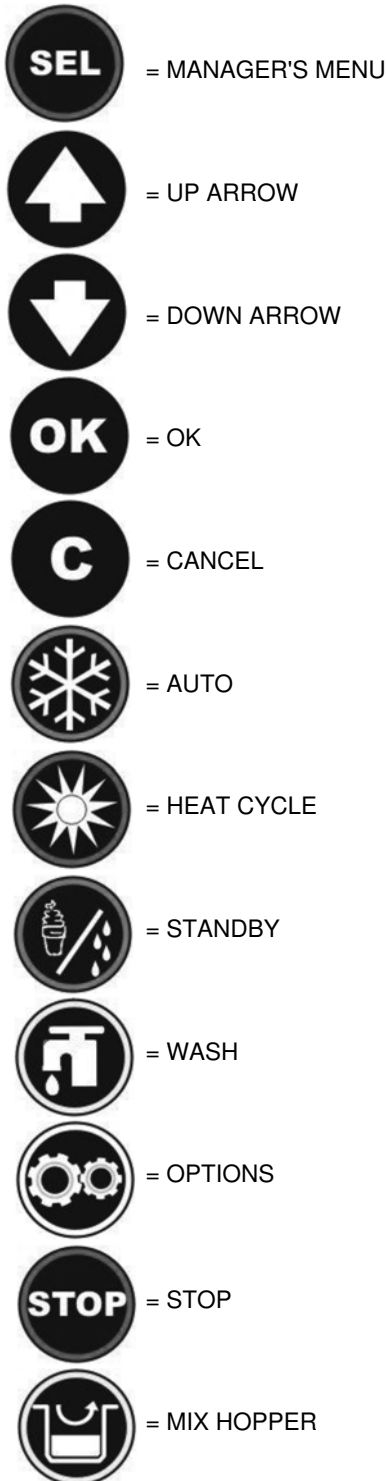

Figure 5-2

LCD Display

The display is located on the front control panel. The display is used to show menu options and notifies the operator if a fault is detected. The display indicates also the temperature of the mix in the hopper, in the barrel and its level.

Indicator Icons on the Display and Buttons

MIX LOW - When the MIX LOW icon is displayed, the mix hopper has a low supply of mix and should be refilled as soon as possible.

MIX OUT - When the MIX OUT icon is displayed (the "LEVEL" message is displayed), the mix hopper has been almost completely exhausted and has an insufficient supply of the mix to operate the freezer. At this time, the AUTO mode is locked out and the freezer will be placed in STANDBY mode. To initiate the refrigeration system, add mix to the mix hopper. The freezer will automatically begin operation.

BRUSH CLEAN COUNTER - When the BRUSH CLEAN COUNTER display has counted down to "1," the machine must be disassembled and brush cleaned within 24 hours.

Manager's Menu Button

The Manager's Menu is used to enter the operator function displays. To access the Menu, press the SEL button.

Up ARROW Button

If active, it increases the value of the set.

Down ARROW Button

If active, it decreases the value of the set.

OK Button

If active, it confirm the value of the set.

C Button

If active, it deletes the set value or exits the menu. In AUTO mode, the C button displays the temperature of the barrel, the CTS system temperature and the glycol temperature.

AUTO Button

The AUTO button will illuminate when it is pressed. This indicates that the refrigeration system has been activated. In the AUTO mode, the WASH or STANDBY functions are automatically canceled.

HEAT Button

When the HEAT MODE button is illuminated, the freezer is in the process of a heat cycle.

STANDBY Button

The Standby feature maintains product temperatures in both the hopper and the barrel below 40°F (4.4°C). This feature is useful during long "No Sale" periods to prevent overbeating and product breakdown.

When STANDBY is selected, the STANDBY button illuminates, indicating the Standby feature has been activated. In the STANDBY mode, the WASH and AUTO functions are automatically canceled.

To resume normal operation, press the AUTO button. When the machine cycles off, the product in the barrel will be at serving viscosity.

WASH Button

The WASH button will illuminate when pressed. This indicates beater motor operation.

OPTION Button

The OPTION button, if pressed simultaneously with the AUTO button and held down for at least 5 seconds, allows the access to the adjustment menu for the product consistency and for the agitator motor cycle adjustment during the Auto mode.

The OPTION button, if pressed simultaneously with the STANDBY button and held down at least 5 seconds, allows access to the adjustment menu for the product temperature and for the agitator motor cycle adjustment during the Standby mode.

STOP Button

The STOP button will illuminate when pressed. This indicates the machine is off.

Mix Hopper Agitator

When the MIX HOPPER AGITATOR button is illuminated, the agitator in the hopper is on.

Keypad Lock

To lock the control panel and prevent accidental use (ex: self-service applications) press and hold the OK button for at least 5 seconds; the closed padlock icon appears on the left side of the display to indicate that each function pushbutton is disabled.

To unlock the control panel, press and hold the OK button for at least 5 seconds.

Operating Screen Description

When the machine is powered, the control system will initialize to perform a system check. The screen will display the Taylor logo for a few seconds.

Main Power Switch OFF

When the main power switch is OFF, the following screen is displayed in International date sequence (DD/MM/YY).



Figure 5-3

Main Power Switch ON

When the main power switch is placed in the ON position, the control panel buttons become operative and the following screen is displayed.



Figure 5-4

Heat Cycle

The HEAT CYCLE button on the control panel is illuminated throughout the heat treatment cycle.

- **Do not** attempt to draw product or disassemble the machine during the HEAT cycle. The product is hot and under extreme pressure.

5 In the HEAT CYCLE, the mix temperature in the hopper and barrel must be raised to 156°F (69°C) within 90 minutes.

When the heating phase is complete, the freezer goes into the holding phase of the cycle. The holding phase will keep the temperature above 156°F (69°C) for a minimum of 45 minutes.

The final phase of the heat treatment cycle is the cooling phase. The freezer must cool the mix below 41°F (5°C) within 120 minutes.

When the entire heat cycle has been completed, the machine will enter the STORAGE mode. The machine can be placed in AUTO or left in STORAGE.

To comply with health codes, heat treatment system freezers must complete a heat treatment cycle daily and must be disassembled and brush cleaned according to the frequency specified by your Federal, State, or local regulatory agencies. Please consult your governing Health Codes to determine the maximum number of days allowed between brush clean cycles.

Brush cleaning is the normal disassembly and cleaning procedure found in the Operator Manual. Failure to follow these guidelines will cause the control to lock the freezer out of the AUTO mode.

Always comply with local Health Codes for the maximum number of days allowed between brush clean cycles.

Freezer Locks

There are two types of freezer lock conditions that can occur: Hard Lock or Soft Lock:

- A Hard Lock requires the machine be disassembled and brush cleaned.
- A Soft Lock can be corrected by either disassembling and brush cleaning the machine, or by starting another heat treatment cycle.

Hard Lock

The machine will hard lock if either the brush clean timer has elapsed or if a thermistor failure (freezing cylinder or hopper) occurs during the heat cycle.

The following screen will be displayed if a brush clean cycle time has occurred.

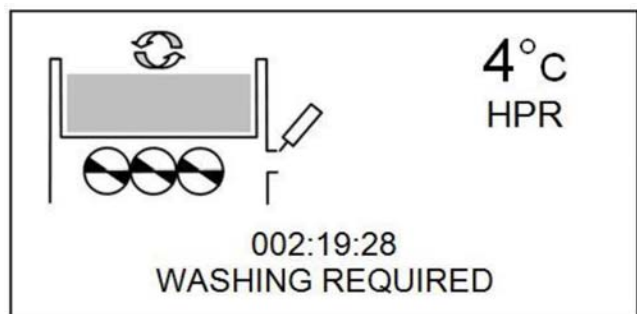

Figure 5-5

If the machine has hard locked and an attempt is made to enter AUTO, the machine will remain in the STANDBY mode and will not allow any dispensing.

The WASHING REQUIRED message will remain on the display until the brush clean requirements are fulfilled. To reset the hard lock, turn the main power switch OFF for at least 5 minutes and disassemble the freezer for cleaning procedure.

Soft Lock

If a heat treatment cycle has not been initiated within the last 24 hours, a soft lock failure will occur. A soft lock allows the operator to correct the cause of the soft lock. The operator has the option of either starting another heat cycle or brush cleaning the machine. When a soft lock occurs, the machine will go into STANDBY mode. The message "Freezer Locked - Heat Treat Required" is displayed on the screen. The reason for soft lock is indicated in the "Lockout History" in the Manager's Menu (SEL button).

If the reason for the soft lock has been corrected, selecting HEAT CYCLE initiates a heat cycle immediately.

A soft lock can also occur any time during operation when the hopper or barrel temperature rises above 59°F (15°C), the temperature rises and remains above 45°F (7°C) for more than 1 hour, or the temperature rises and remains above 41°F (5°C) for more than 4 hours.

If a product over temperature condition occurs during operation, the message "Freezer Locked - Heat Treat. Required" is displayed on the screen.

When one of these messages appears, automatic freezer operation cannot take place until the freezer is disassembled and brush cleaned, or has completed a heat treatment cycle.

Note: A record of Heat Cycle Data and Lockout History can be found in the Manager's Menu (SEL button).

Manager's Menu

The Manager's Menu is used to enter the operator function displays. To access the Menu, press the SEL button.

In the Menu program, the ARROW buttons, the OK button, and the C button will function as menu buttons.

- UP ARROW - increases the value above the cursor and is used to scroll upward in text displays.
- DOWN ARROW - decreases the value above the cursor and is used to scroll downward in text displays.
- OK - Confirms the selected value
- C - Deletes the selected value

There is a 1-minute time-out in effect during the Manager's Menu. While in the Manager's Menu, if no activity occurs within a 1-minute period, the display will exit to the main screen.

Note: The machine will continue operation in the mode it was in when the Menu was selected. However, the control buttons will not be lit and are non-functional when the Manager's Menu is displayed.

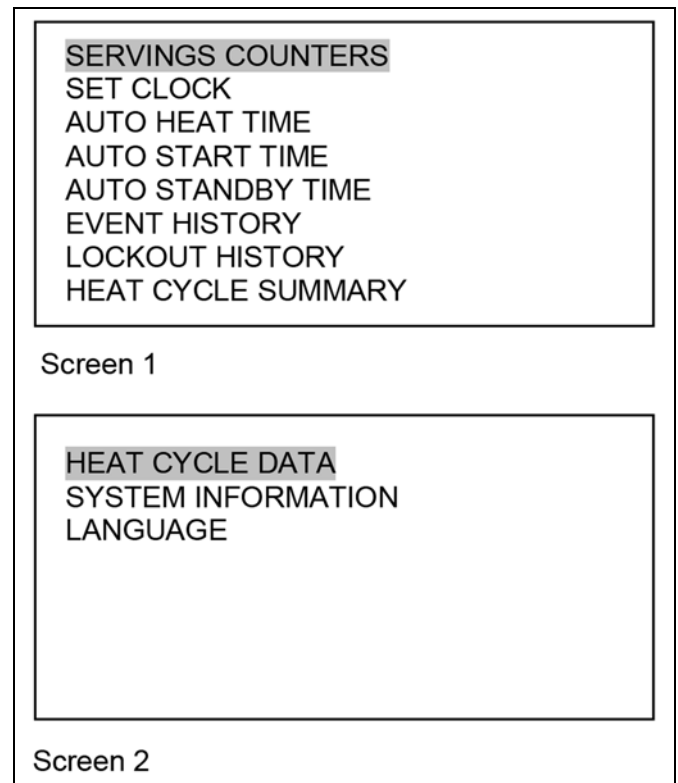

Figure 5-6

Manager Menu Options

Press the SEL button to enter in the Manager's Menu. Press the ARROW buttons to move up or down through the Menu. Select a Menu option by pressing the OK button.

The following menu options are listed in the Manager's Menu.

- SERVINGS COUNTER
- SET CLOCK
- AUTO HEAT TIME
- AUTO START TIME
- AUTO STANDBY TIME
- EVENT HISTORY
- LOCKOUT HISTORY
- HEAT CYCLE SUMMARY
- HEAT CYCLE DATA
- SYSTEM INFORMATION
- LANGUAGE

Exit the Menu program by touching the STOP or C button.

Servings Counter

The SERVINGS COUNTER option is used to check the total and partial number of servings dispensed from the machine. The partial counter will automatically reset to zero when the machine is cleaned; you can also reset this counter manually by selecting the OK button to confirm the operation.

The total counter cannot be reset by the operator.

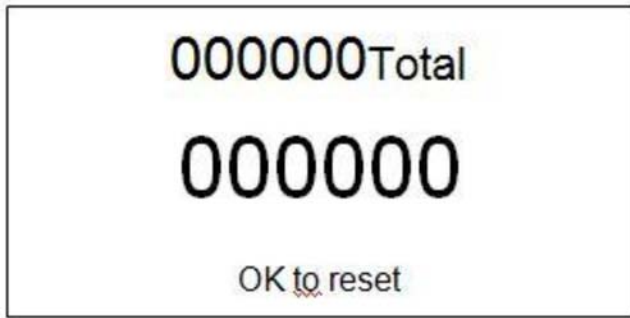

Figure 5-7

Set Clock

5 The SET CLOCK option allows the manager to adjust the control clock, date, and time. The date and time may only be changed after the freezer has been manually cleaned, but before it has been placed in AUTO or STANDBY mode. The following message will be displayed if the SET CLOCK option is selected.

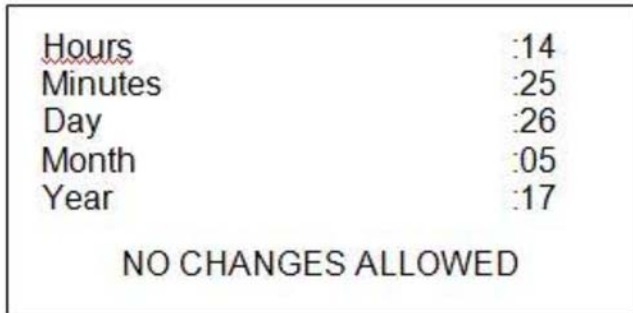

Figure 5-8

To change the data or time, select the SET CLOCK option in the menu. The hour setting is automatically selected; press the ARROW buttons to increase or decrease the value. Press the OK button to confirm the value and to advance to the next entry. Enter the correct minutes, day, month, and year, then press the OK button to save and return to the Main Menu.

Auto Heat Time

The AUTO HEAT TIME screen allows the manager to set the time of day in which the heat treatment cycle will start if the machine is in AUTO or STANDBY mode.

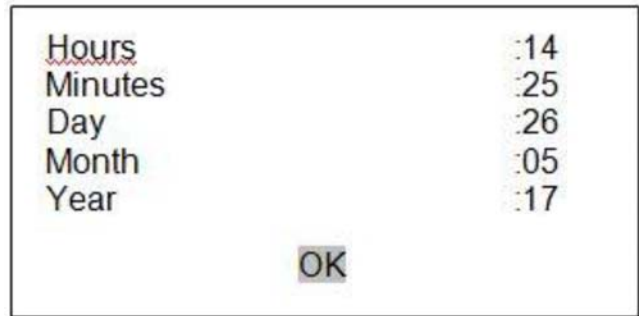

Figure 5-9

The hour setting is automatically selected; press the ARROW buttons to increase or decrease the value. Touch the OK button to confirm the value and to advance to the next entry. Enter the correct minutes and press the OK button to save and return to the Main Menu.

Auto Start Time

The AUTO START TIME option allows the manager to set the time of day at which the machine automatically enters the AUTO mode from the STANDBY/STORAGE mode. The machine must be in the STANDBY/STORAGE mode without a freezer lock condition in order to AUTO start at the programmable time. The AUTO START TIME can also be disabled and require starting the AUTO mode manually.

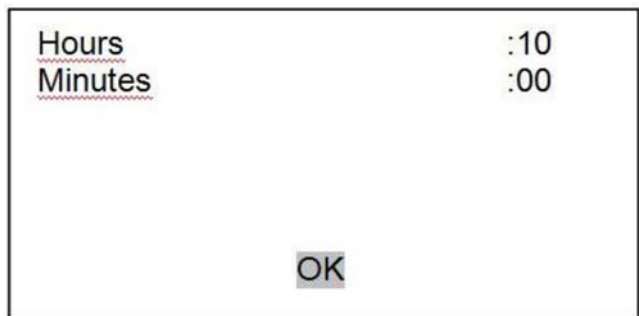

Figure 5-10

The hour setting is automatically selected; press the ARROW buttons to increase or decrease the value. Touch the OK button to confirm the value and to advance to the next entry. Enter the correct minutes and press the OK button to save and return to the Main Menu.

Note: Disable the AUTO START TIME by selecting "- -" in "hours" settings.

Auto Standby Time

The AUTO STANDBY TIME option allows the manager to set the time of day at which the machine automatically enters the STANDBY mode from the AUTO mode. This allows power savings during slow sales. The AUTO STANDBY TIME can also be disabled and require starting the STANDBY mode manually.

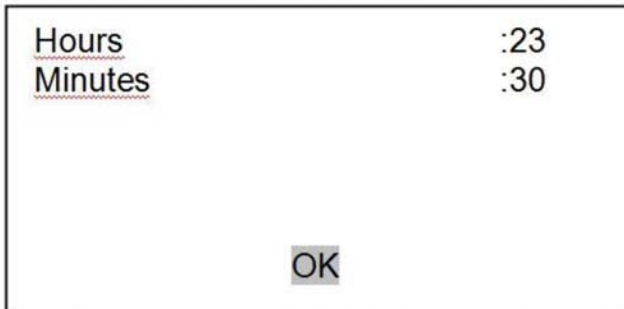

Figure 5-11

The hour setting is automatically selected; press the ARROW buttons to increase or decrease the value. Press the OK button to confirm the value and to advance to the next entry. Enter the correct minutes and press the OK button to save and return to the Main Menu.

Note: Disable the AUTO STANDBY TIME by selecting "-" in "hours" settings.

Event History

The EVENT HISTORY screen will display up to 200 events. The most recent event is displayed on screen 1. The data and time description is displayed on each screen. Press ARROW buttons to display the next screen; press the OK or C button to return to the main menu.

Listed below are the variable messages which will appear, along with an explanation of the corrective action.

DOOR O. - (DOOR OPEN) A product door is not in place or it is loose.

FLU.LEV. - (ALARM - INSUFFICIENT FLUID LEVEL)

The fluid level is too low to operate; switch off the machine. Call your authorized service technician.

TEV INT. - (ALARM - PROBE TEV INTERRUPTED) The hopper thermistor is open; switch off the machine. Call your authorized service technician.

TEV S.C. - (ALARM - PROBE TEV SHORT CIRC.) The hopper thermistor has shorted; switch off the machine. Call your authorized service technician.

TEC INT. - (ALARM - PROBE TEC INTERRUPTED) The barrel thermistor is open; switch off the machine. Call your authorized service technician.

TEC S.C. - (ALARM - PROBE TEC SHORT CIRC.) The barrel thermistor has shorted; switch off the machine. Call your authorized service technician.

TEF INT. - (ALARM - PROBE TEF INTERRUPTED) The fluid thermistor is open; switch off the machine. Call your authorized service technician.

TEF S.C. - (ALARM - PROBE TEF SHORT CIRC.) The fluid thermistor has shorted; switch off the machine. Call your authorized service technician.

CTS INT. - (ALARM - PROBE CTS INTERRUPTED) The CTS thermistor is open; switch off the machine. Call your authorized service technician.

CTS S.C. - (ALARM - PROBE CTS SHORT CIRC.) The CTS thermistor has shorted; switch off the machine. Call your authorized service technician.

THERMAL - (ALARM - THERMAL OVERLOAD) Press the STOP button and wait 5 minutes for the machine to cool. Restart in AUTO. If the alarm continues, call your authorized service technician.

PHASES - (ALARM - PHASES L2-L3 SWITCHED) Press the STOP button and switch off the machine. Call your authorized service technician.

PHASES/N - (ALARM - SWITCH PHASE / NEUTRAL) Press the STOP button and switch off the machine. Call your authorized service technician.

MICRO TA - (ALARM - NO CURRENT SIGNAL OR DEFECTIVE TRANSFORMER) Press the STOP button and switch off the machine. Call your authorized service technician.

DEV. KO - (ALARM - DEVICE KO!) Switch off the machine. Call your authorized service technician.

COM. KO - (ALARM - COMMUNICATION ERROR!) Switch off the machine. Call your authorized service technician.

TIME OUT - (ALARM - BATCH TIME OUT) The compressor run time exceeded the 120-minute timer. Replace the scraper blades during the next brush cleaning. If that does not resolve the fault, call your authorized service technician.

Lockout History

The LOCKOUT HISTORY screen displays a history of the last 200 soft locks, hard locks and aborted heat cycles. The most recent lockout is displayed on screen 1. The data and time description is displayed on each screen. Press the ARROW buttons to display the next screen; press OK or C button to return to the main menu.

The following variable messages which will appear, along with an explanation of the corrective action.

Faults occurring while in Heat Mode:

LOCK HT - (HEAT MODE FAILURE) The maximum allowable heat mode time exceeded 90 minutes.

LOCK CL - (COOL MODE FAILURE) The maximum allowable cool mode time exceeded 120 minutes.

LOCK TT - (TOTAL TIME FAILURE) The maximum allowable total heat treatment time exceeded 4 hours.

LOCK OP - (OPERATOR ABORT) The operator has aborted the heat treatment cycle.

WARN. PS - (POWER FAIL IN H/C) A power failure occurred during the heat treatment cycle.

5 WASHING REQUIRED - (BRUSH CLEAN TIMEOUT) The total days in operation exceeded the brush clean cycle setting.

Faults Occurring While in AUTO Mode:

HP 5C 4H - The mix temperature in the hopper was above 41°F (5°C) more than four hours.

BR 5C 4H - The mix temperature in the barrel was above 41°F (5°C) more than four hours.

HP 5C PF - The mix temperature in the hopper was above 41°F (5°C) more than four hours following a power failure.

BR 5C PF - The mix temperature in the barrel was above 41°F (5°C) more than four hours following a power failure.

HP 7C 1H - The mix temperature in the hopper was above 45°F (7°C) more than one hour.

BR 7C 1H - The mix temperature in the barrel was above 45°F (7°C) more than one hour.

HP 15C - The mix temperature in the hopper exceeded 59°F (15°C).

BR 15C - The mix temperature in the barrel exceeded 59°F (15°C).

Heat Cycle Summary

The HEAT CYCLE SUMMARY screen displays the hours since the last heat cycle, the hours since the product temperature was above 150°F (65.6°C), and the number of heat cycles completed since the last brush clean date.

Hrs since HC	:0
Hrs since 65°C	:0
HC since BC	:0

Figure 5-12

Heat Cycle Data

The HEAT CYCLE DATA screen contains a record up to 400 heat treatments cycles. The most recent heat cycle is displayed on screen 1. The data and time description is displayed on each screen. Press ARROW buttons to display the next screen; press C button to return to the main menu.

OK	26/05	03:00
OK	25/05	13:26
OK	25/05	03:00
OK	23/05	03:00
OK	22/05	03:00
FAILED	21/05	03:00

Figure 5-13

Select the desired cycle and press the OK button to open the detail screen. The screen displays the month and day of the heat cycle, the start time and end time. The middle line indicates if an alarm or a lockout occurred during the heat cycle.

The remaining lines indicate the following:

- HEAT = Total time for the hopper (H) and barrel (B) to reach 150 °F (65.6°C).
- OVER = Total time the hopper (H) and barrel (B) temperature was above 150 °F (65.6°C).
- COOL = Total time the hopper (H) and barrel (B) temperature was above 41°F (5°C) during the COOL phase.

- PEAK = Highest temperature reading for the hopper (H) and barrel (B) during the heat treatment cycle.

Date	Start	End	
26/05	03:00	05:16	
	Alarm <input type="checkbox"/>	Lockout <input type="checkbox"/>	
Heat	Over	Cool	Peak
H 0:48	1:33	0:42	72°C
B 0:35	1:48	0:38	71°C

Figure 5-14

Press the DOWN ARROW button to advance to the next heat cycle stored.

System Information

The SYSTEM INFORMATION screen displays the part number of the machine, the LCD, and the main board software release.

Press the C button to return to the main menu.

Part number	:0000000
LCD Ver :	1.1 24/05/17
I/O Ver :	1.2 23/05/17

Figure 5-15

Language

The LANGUAGE screen allows the manager to set the language of the display. Press the ARROW buttons to scroll through the list of available languages; press the OK button to confirm your choice. Press the OK button again to save and exit to the menu.

Language	:ENG
----------	------

Figure 5-16

This machine stores mix in a hopper. It has a 2.1 quart (2.0 liter) capacity barrel with a single spout door.

We begin our instructions at the point where we enter the store in the morning and find the parts disassembled and laid out to air dry from the previous night's cleaning. These opening procedures will show you how to assemble these parts into the freezer, sanitize them, and prime the freezer with fresh mix in preparation to serve your first portion. If you are disassembling the machine for the first time or need information to get to this starting point in our instructions, turn to page 6-11, "Disassembly," and start there.

Assembly

Note: When lubricating parts, use an approved food grade lubricant (example: Taylor Lube). **MAKE SURE THE MACHINE IS DISCONNECTED!** Failure to follow this instruction may result in severe personal injury from hazardous moving parts.

Beater Assembly

1. Attach the scraper blade to the beater assembly at the locations as indicated. Repeat this step for the others scraper blades.

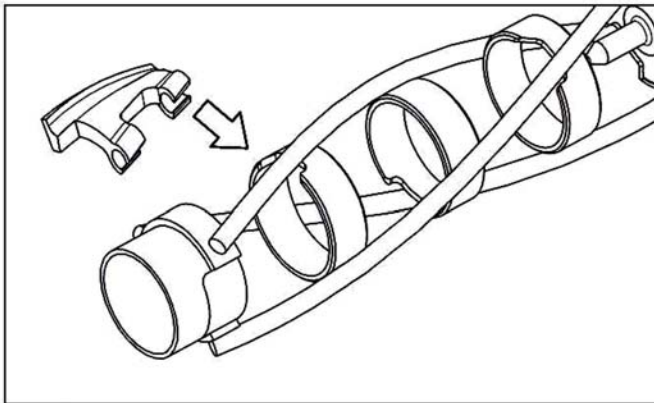

Figure 6-1

2. Insert the beater auger on the beater body; Make sure the lip of the auger is inserted in the slot of the beater.

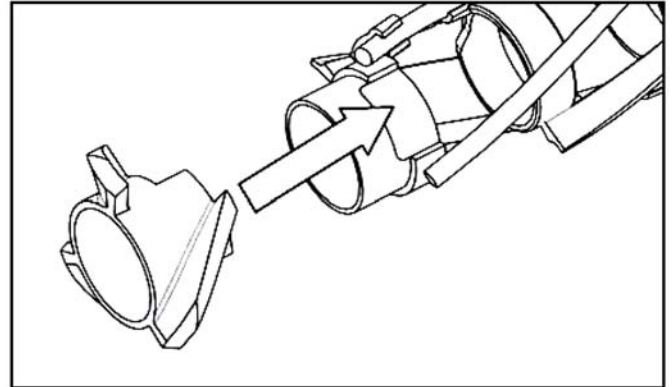

Figure 6-2

3. Lightly lubricate both sides of the beater drive shaft seal. Slide this seal up to the stop. **Do not** lubricate the square end.

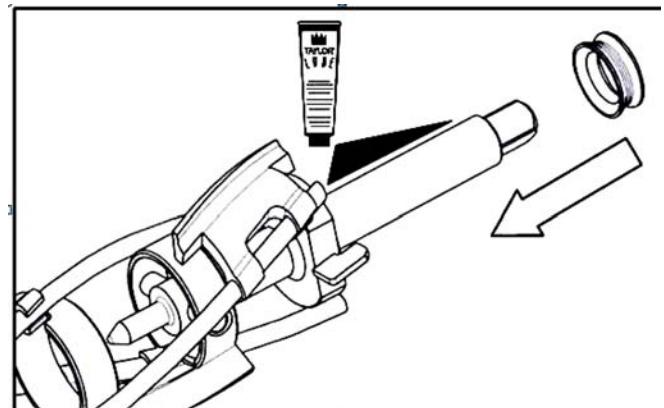

Figure 6-3

OPERATING PROCEDURES

4. Holding the beater securely, slide the beater assembly into the freezer cylinder while lightly compressing the scraper blades. Slide the beater into the barrel and engage the square end firmly into the drive coupling.

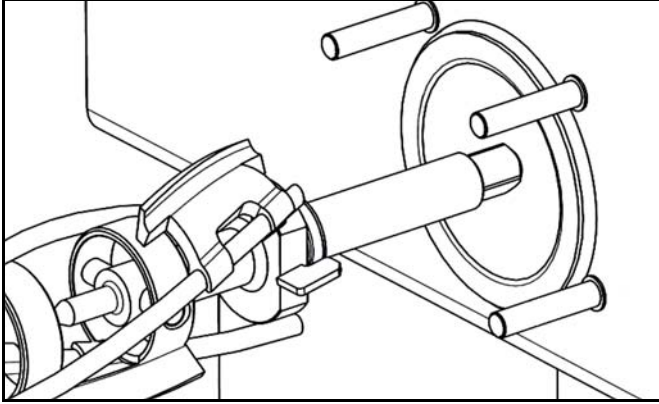

Figure 6-4

Freezer Door Assembly

1. Place the door O-ring into the groove on the back of the freezer door.

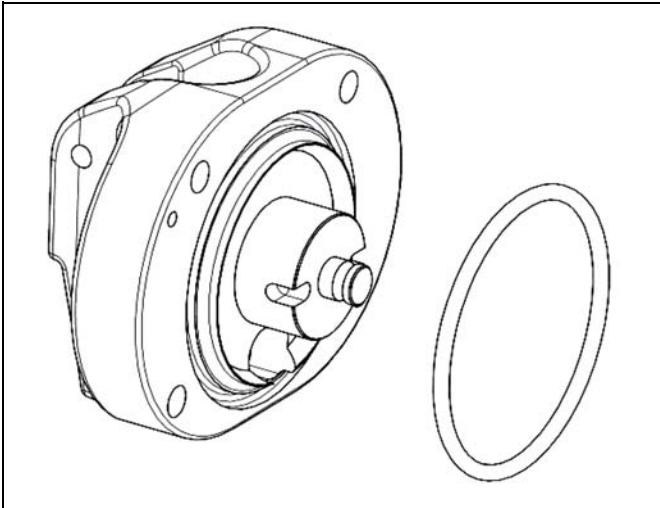

Figure 6-5

2. Slide the two O-rings into the grooves on the draw valve and lubricate them.

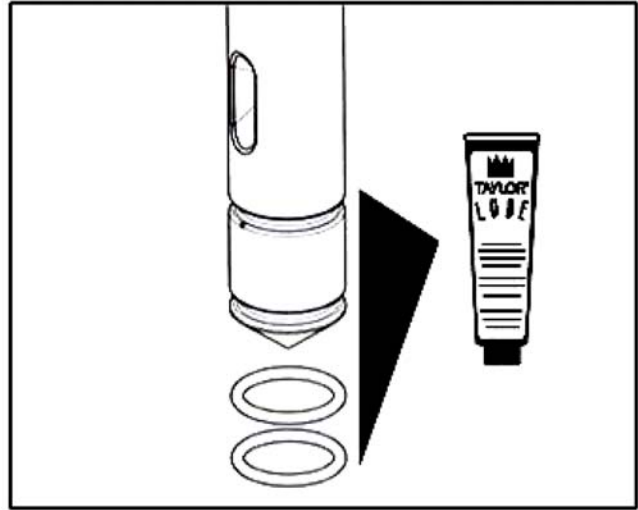

Figure 6-6

3. Lightly lubricate the inside of the top of the freezer door valve cavity.

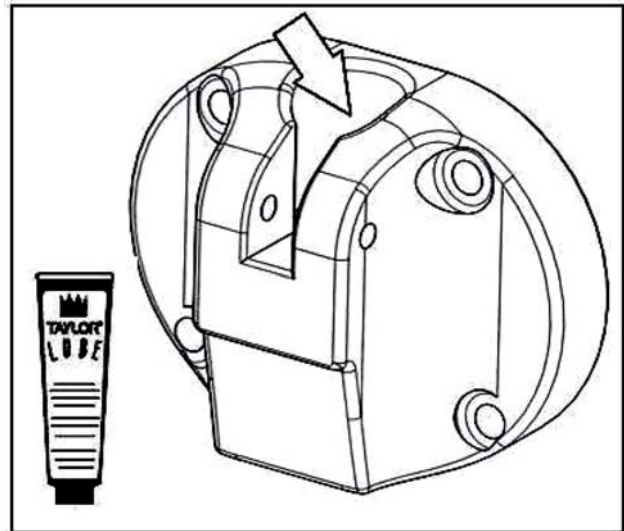

Figure 6-7

Note: If the draw valve is inserted with the flat surface facing the user, this will prevent the machine from operating.

4. Insert the draw valve from the top, with the flat part facing toward the machine.

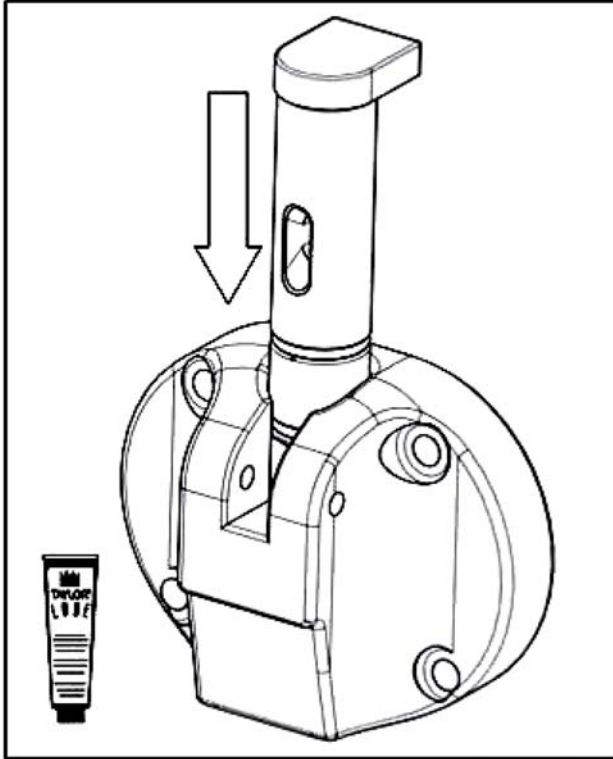

Figure 6-8

5. Insert the counter-beater on the rear pin on the freezer door and rotate it until the pins align with the holes in the door. Place the counter-beater O-ring into the groove on rear pin of the freezer door.

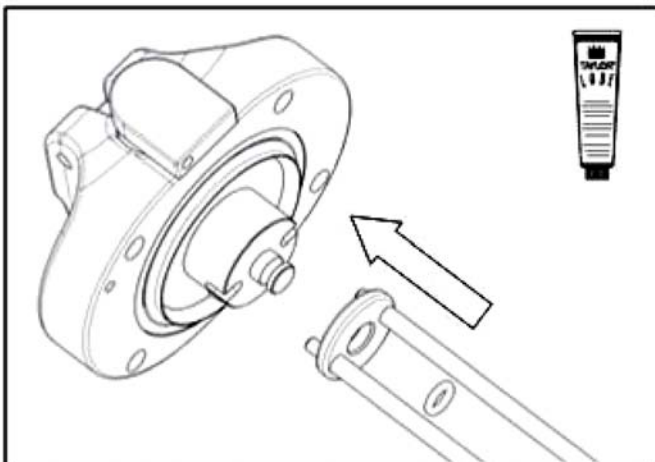

Figure 6-9

6. Insert the plastic bushing into the back of the counter-beater. Place the O-ring into the groove of the bushing.

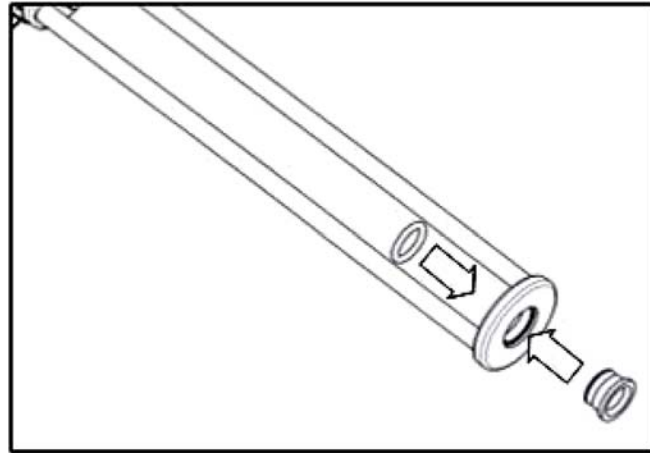

Figure 6-10

7. With both hands, hold the sides of the freezer door and insert the counter beater into the center of the beater assembly. The counter-beater rear bushing must fit securely onto the pin at rear of the beater.

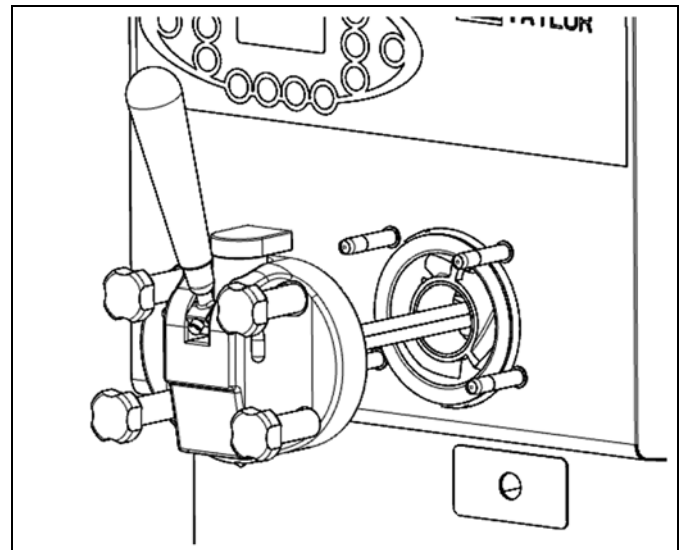

Figure 6-11

OPERATING PROCEDURES

8. With the door seated on the freezer studs, install the handscrews. Tighten them equally in a criss-cross pattern to insure the door is snug.

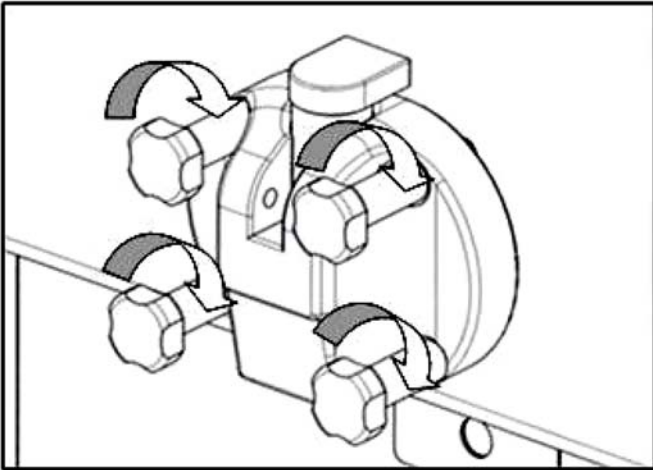

Figure 6-12

9. Insert the handle body O-ring handle in the groove in the side of draw handle body.

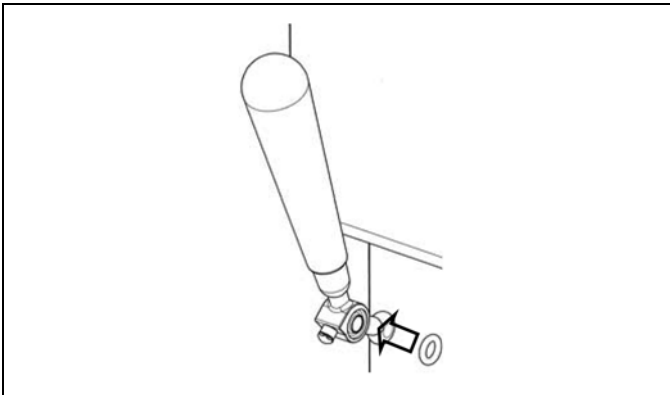

Figure 6-13

10. Position the draw handle with the adjustment screw facing down. Slide the ball of the draw handle into the slot of the draw valve. Secure the draw handle to the door using the pivot pin. Place the handle pin O-ring in the groove at the end of the pin.

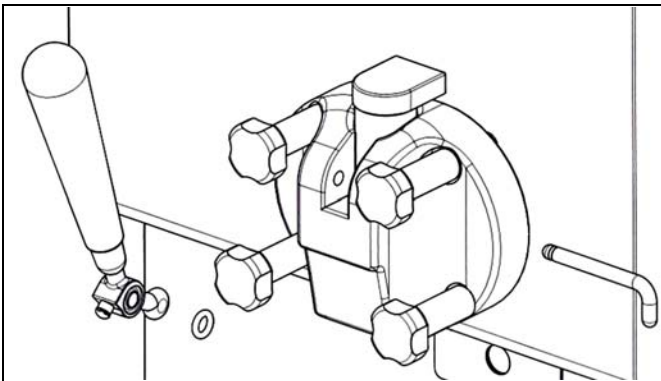

Figure 6-14

11. Slide the drip pan into the hole in the front panel.

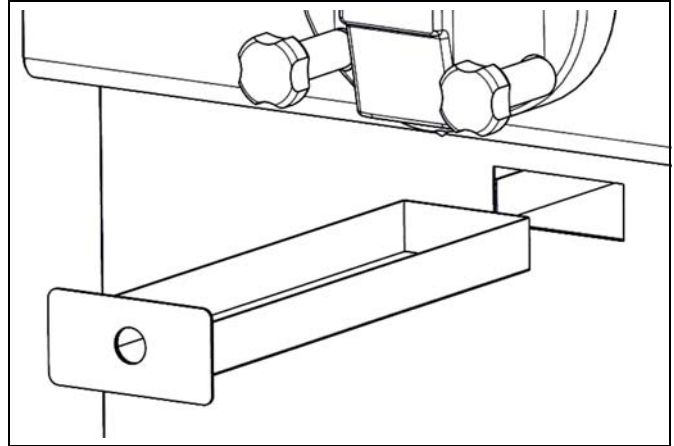

Figure 6-15

12. Install the front drip tray bracket, the rubber drip tray, and the splash shield under the door spout.

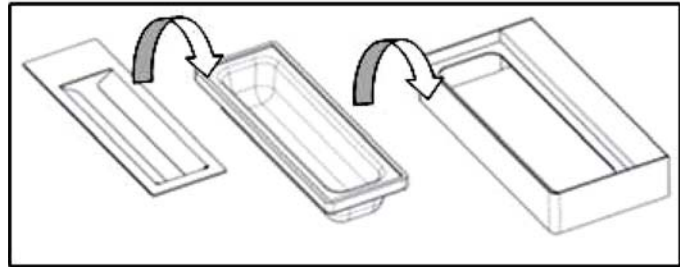

Figure 6-16

Mix Pump Assembly

1. Inspect the rubber and plastic pump parts. The O-rings must be in 100% good condition for the pump and entire machine to operate properly. They cannot properly serve their intended function if nicks, cuts, or holes in the material are present.
Inspect the plastic pump parts for cracks, wear, and delamination of plastic.
Replace any worn, damaged, or inoperable parts immediately.
2. Place the pump body O-ring in the groove.

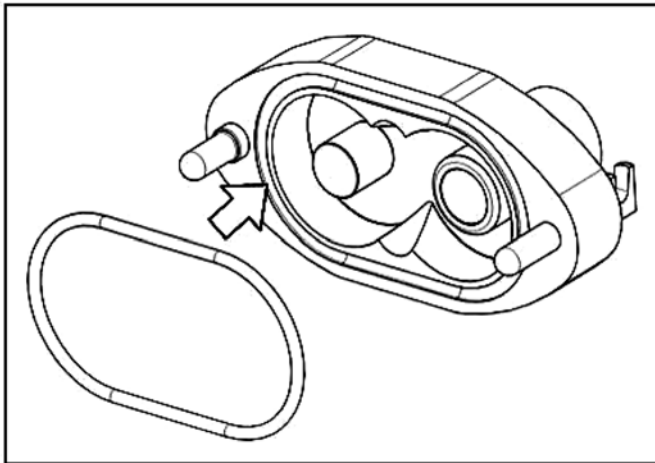

Figure 6-17

3. Place the two pump O-rings into the groove on the back of the pump body and lubricate them.

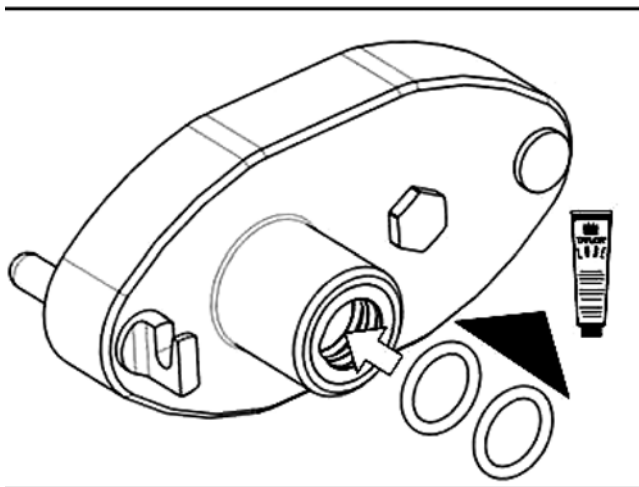

Figure 6-18

4. Lubricate the interior surfaces of the pump body (rear wall, pin, and bushing).

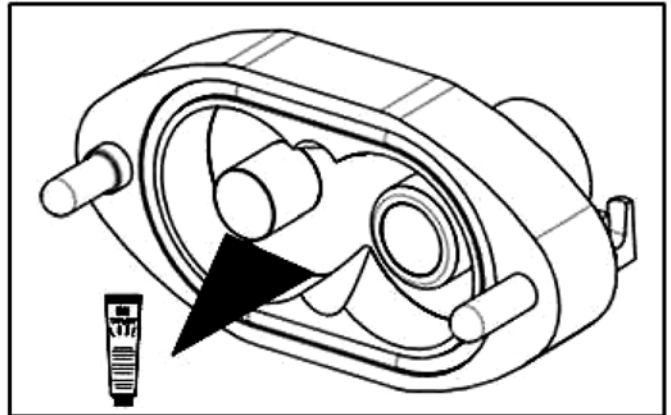

Figure 6-19

5. Insert the drive gear on the bushing; check that the upper face of the gear is flush with the rim of the pump body.

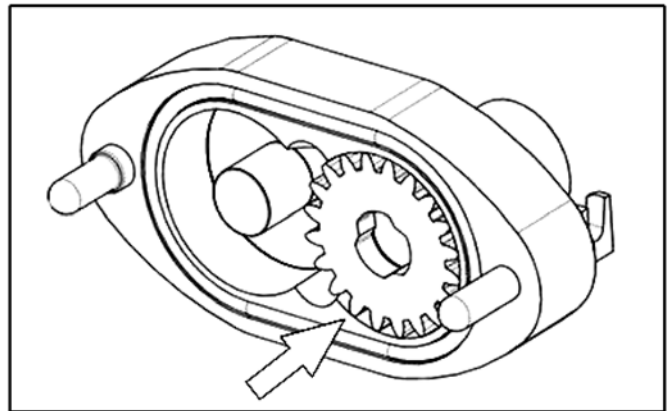

Figure 6-20

6. Insert the driven gear on the pin; check that the upper face of the gear is flush with the rim of the pump body. Lightly lubricate the flat faces of both gears.

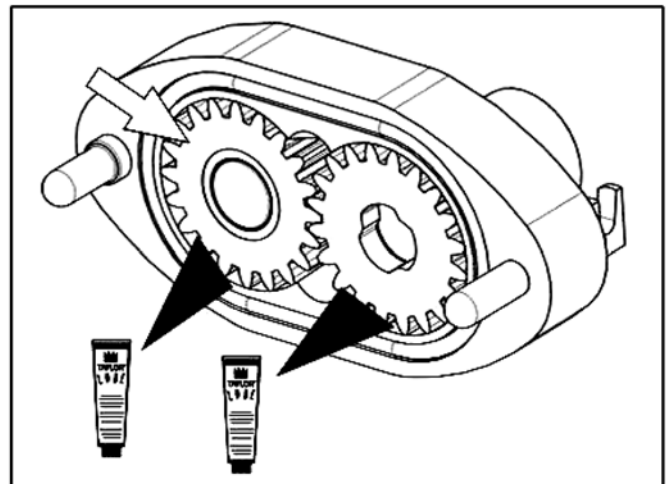

Figure 6-21

OPERATING PROCEDURES

7. Install the pump cover on the pump body studs.

Note: The pump cover holes have different diameters to prevent incorrect assembly.

Install the handscrews and tighten them equally to make sure the pump is closed.

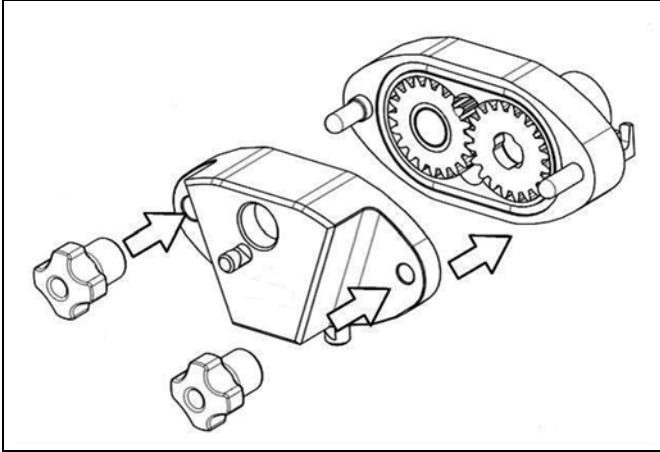

Figure 6-22

Note: Do not lubricate the graduated holes.

8. Slide the regulator O-ring into the groove on the liquid regulator and lubricate.

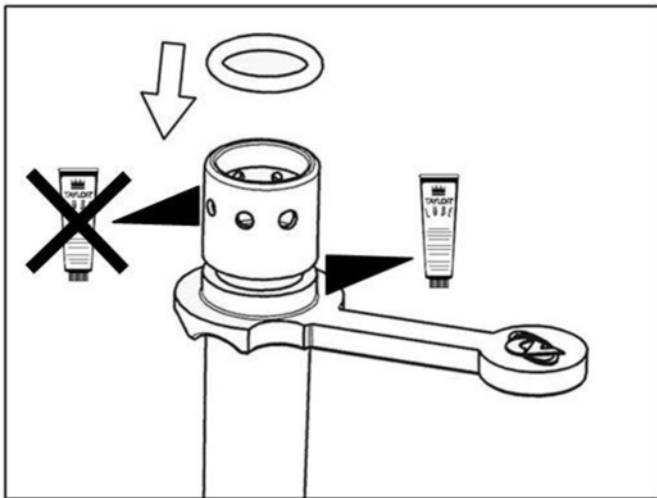

Figure 6-23

9. Insert the regulator spring into the liquid regulator seat. Insert the pump valve into the spring so the larger part is out of the spring.

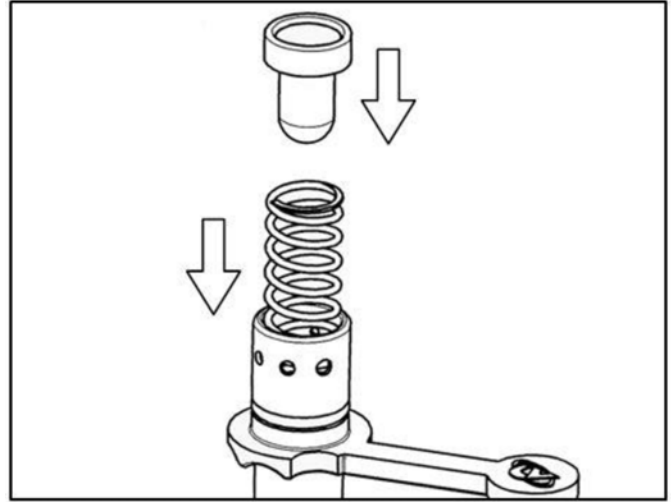

Figure 6-24

10. Insert the liquid regulator into the hole located on the bottom of the pump cover, aligning the notch with the retaining pin. Rotate to lock in place.

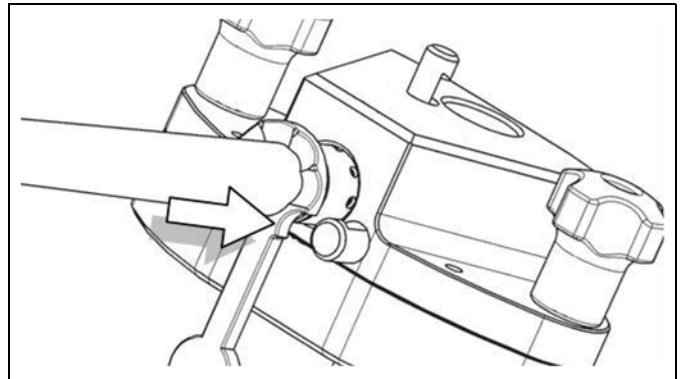

Figure 6-25

11. The regulator can be adjusted to six available positions to achieve the desired overrun.

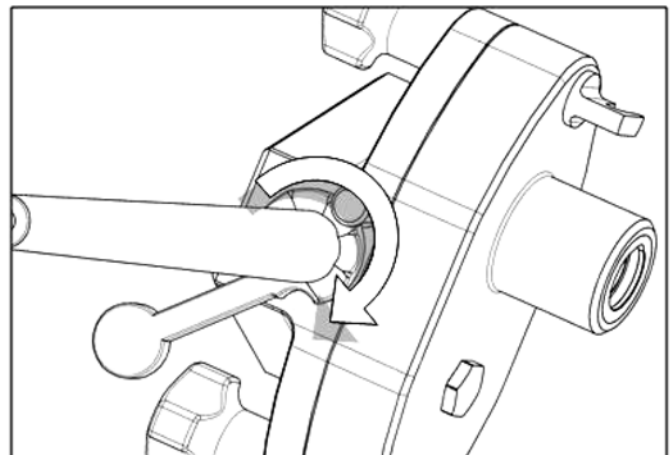

Figure 6-26

Feed Tube Assembly

- 1. Slide one feed tube O-ring into the groove on the bushing and lubricate.

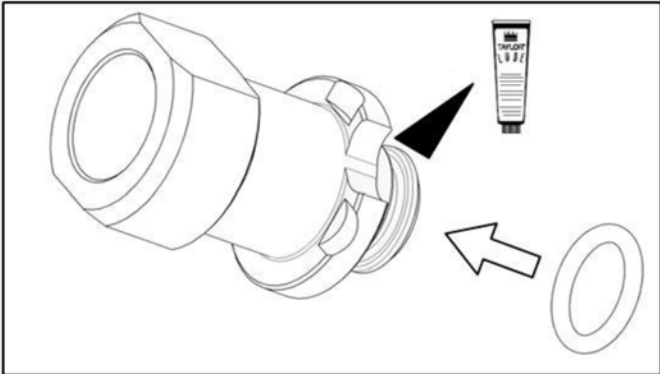

Figure 6-27

Note: Make sure the valve is properly seated in the tube. **Do not** lubricate the duck-bill valve.

- 2. Slide the additional feed tube O-rings into the grooves on the feed-tube and lubricate them. Insert the duck bill valve into the feed tube until it slides in place in the groove.

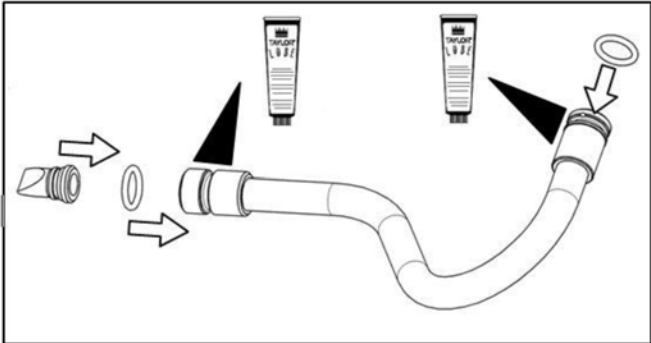

Figure 6-28

- 3. Place the feed tube coupling onto the feed tube until it reaches the stop position.

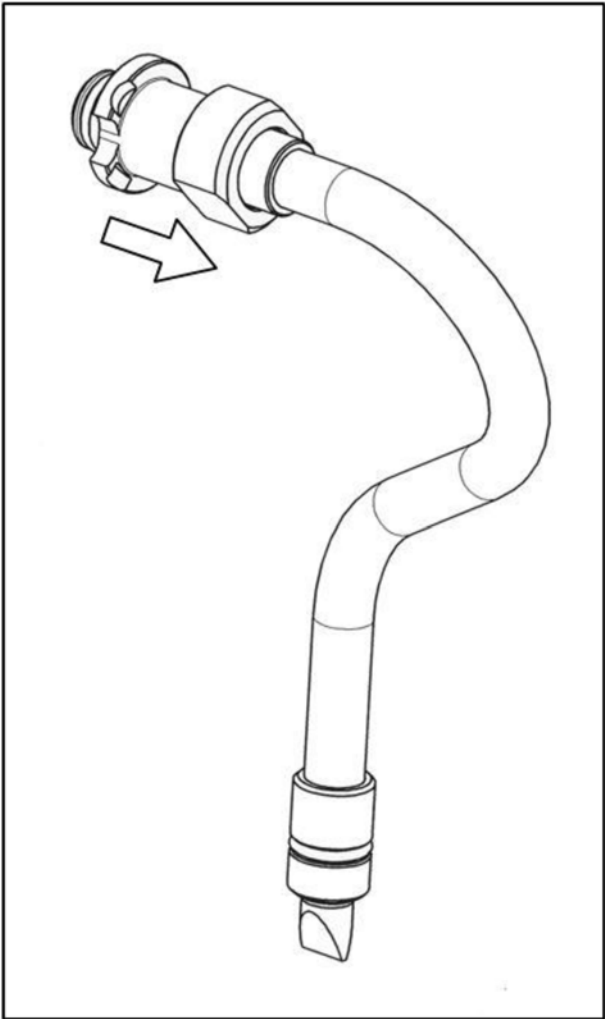

Figure 6-29

- 4. Lay the hopper agitator, the feed tube and the complete pump in the bottom of the mix hopper for sanitizing.

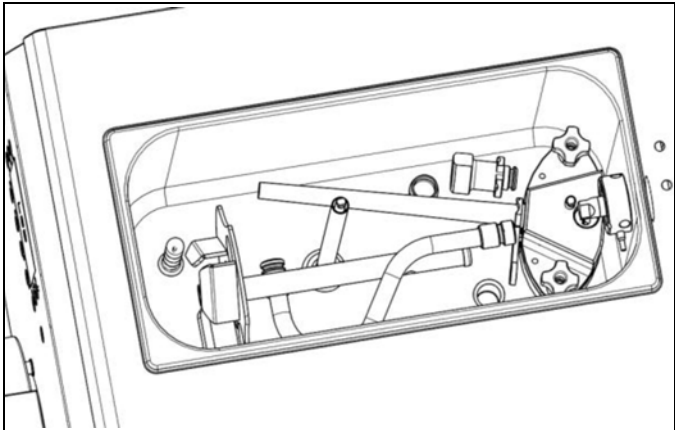

Figure 6-30

Sanitizing

1. Prepare an approved 100 PPM sanitizing solution (example: 2-1/2 gal. [9.5 liters] of Kay-5[®] or 2 gal. [7.6 liters] of Stera-Sheen[®]). Use warm water and follow the manufacturer's specifications.
2. Pour the sanitizing solution over all the parts in the bottom of the mix hopper and allow it to flow into the barrel.

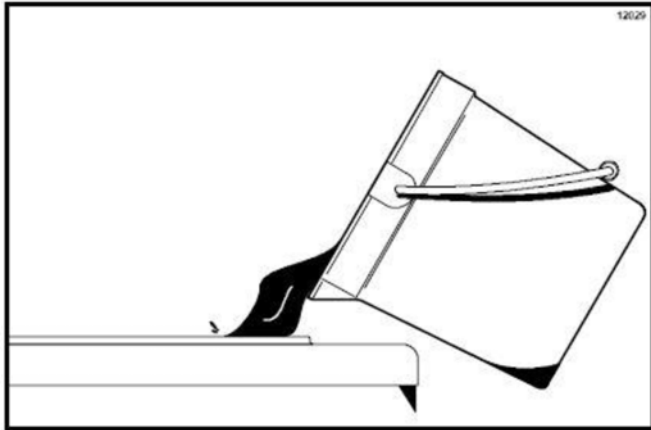

Figure 6-31

Note: You have just sanitized the mix hopper and parts; therefore, make sure your hands are clean and sanitized before performing the following steps.

- 6**
3. While the solution is flowing into the barrel, take particular care to brush-clean the mix level sensing probe on the bottom of the hopper, the mix hopper, the complete air/mix pump, the feed tube, and the hopper agitator.
 4. Brush the exposed sides of the hopper.
 5. Place the main power switch in the ON position.
 6. Press the WASH button. This will cause the sanitizing solution in the barrel to be agitated. Wait at least 5 minutes before proceeding with these instructions. Press STOP button.
 7. Install the pump assembly at the rear of the mix hopper. To position the pump on the support, align the drive hole in the pump body with the drive shaft. Secure the pump in place by rotating the pump assembly until the hook engages with the pivot pin.
Do not attach the feed tube to the pump.

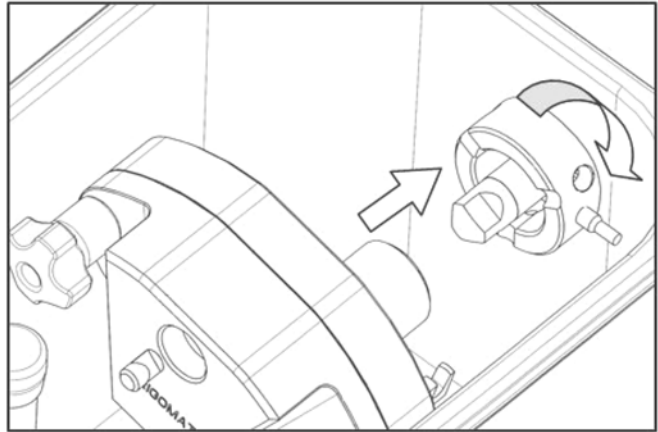

Figure 6-32

8. Press the WASH button. This will cause the sanitizing solution to be circulated through the pump. Wait at least 1 minute before proceeding to the next steps. Open the draw valve and draw off the sanitizing solution from barrel and hopper.
9. Press the STOP button and close the draw valve.
Important! The machine must NOT be placed in AUTO until all sanitizing solution has been removed from the barrel and proper priming procedures have been completed. Failure to follow this instruction may result in damage to the barrel, the beater and/or the door.
- Note:** Make sure your hands are clean and sanitized before proceeding to the next step.
10. Place the hopper agitator on the agitator drive shaft housing. Rest the feed tube against the inside wall of the hopper.

Priming

Note: Use only FRESH MIX when priming the freezer.

1. Place an empty pail beneath the door spout. Pour 2 gallons (8.0 liters) of FRESH mix into the mix hopper and allow it to flow into the barrel.
To remove all sanitizing solution, open the draw valve until fresh mix flows from the door spout, then close the draw valve.
Important! Failure to remove all sanitizing solution may result in damage to the barrel.
2. Allow the mix to continue filling the freezing cylinder.
3. Press the WASH button to prime the pump. Verify that the mix is flowing out of the pump for a few seconds. Press STOP button.

4. Install the assembled feed tube in the mix inlet in the bottom of the hopper. Connect the other end of the feed tube to the outlet of the pump. Secure the feed tube in place by rotating the feed tube coupling. Make sure that the regulator tube is set to the correct position for the desired overrun.

Note: Be sure your hands are clean and sanitized before proceeding to the next step.

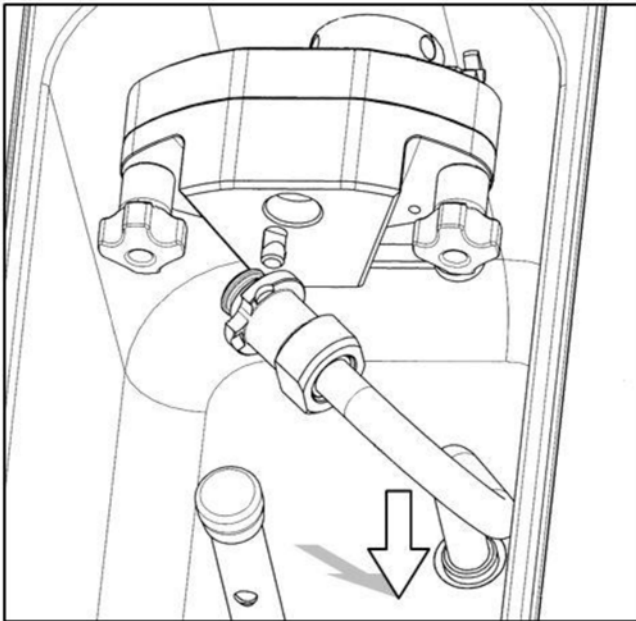

Figure 6-33

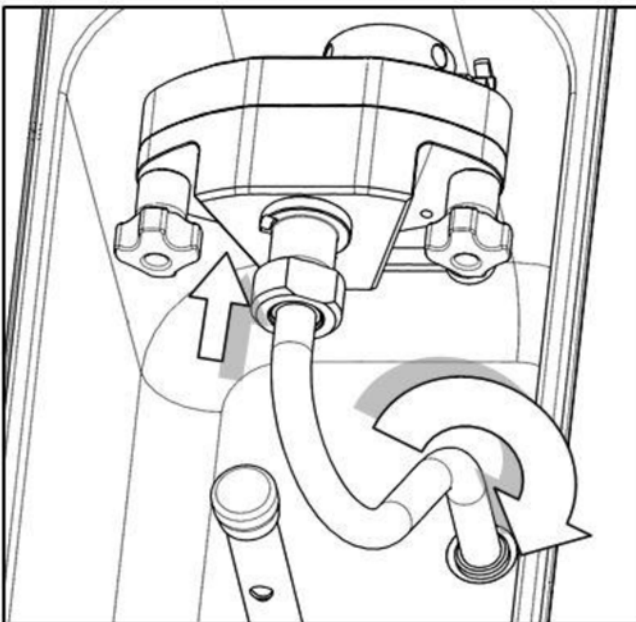

Figure 6-34

5. Press the WASH button. Open and close the draw valve six times to complete the priming procedure.

Note: Use extreme caution when opening the draw valve because the mix is pressurized.
6. Press the AUTO button.
7. Fill the hopper with fresh mix and place the cover in its correct position.

Daily Closing Procedures

This procedure must be performed once daily!

The function of the Heat Treatment Cycle is to destroy bacteria by raising the temperature of the mix in the barrel and the hopper to a specified temperature for a specified period of time, and then bringing the temperature back down low enough to retard spoilage.

The Heat Treatment Cycle will start at the time designated in the Auto Heat Time.

Important! The level of mix in the mix hopper must be enough to cover the level probe.

Note: If the BRUSH CLEAN COUNTER display has counted down to one day, do not add mix. The machine must be disassembled and brush cleaned within 24 hours.

The freezer must be in AUTO (AUTO button illuminated) or in STANDBY/STORAGE mode (STANDBY button illuminated) before the HEAT cycle may be started.

1. Remove the hopper cover.

Important! Make sure your hands are clean and sanitized before performing the following steps.

2. Remove the hopper agitator from the mix hopper.
3. Take the agitator and the hopper cover to the sink for further cleaning and sanitizing.
4. Rinse these parts in cool, clean water.
5. Prepare a small amount of an approved 100 PPM sanitizing solution (example: Kay-5[®] or Stera-Sheen[®]). Use warm water and follow the manufacturer's specifications. Brush clean the agitator and the hopper cover.
6. Install the agitator back onto the agitator drive shaft housing. Replace the hopper cover.

Important! Make sure the agitator is installed and the switch in the AUTO or STANDBY/STORAGE mode or the machine will not have a successful heat cycle.

7. Return to the freezer with a small amount of cleaning solution. Dip the door spout brush into the cleaning solution and brush clean the door spout and the bottom of the draw valve.

Note: To assure sanitary conditions are maintained, brush each item for a total 60 seconds, repeatedly dipping the brush in cleaning solution.

8. Remove, clean, and reinstall the drip tray and splash shield.
9. Using a clean, sanitized towel, wipe down the freezer door, front panel, the area around the bottom of the freezer door, and any other areas that demonstrate a build-up of either moisture or food substance.

The heat cycle will start when the clock on the machine reaches the AUTO HEAT TIME setting in the Manager's Menu.

There are three phases of the heat cycle; Heating, Holding, and Cooling. Each phase has a time limit. If any one of three phases fail to reach the proper temperatures within the time limit, the cycle will automatically abort and return to the STANDBY/STORAGE mode.

A failure message will appear on the LCD to inform the operator that the machine did not successfully complete the heat treatment cycle. The product may not be safe to serve. The freezer will be locked out (soft lock) of the AUTO mode. The operator will be given the option of selecting the HEAT button which will begin a new heat cycle, or touching the MAIN POWER SWITCH which will place the freezer in the OFF mode to allow a brush clean of the machine.

Note: Once the heating cycle has started, it cannot be interrupted. The heating cycle will take a maximum of 4 hours to complete with a full hopper.

Do not attempt to draw product or disassemble the machine during HEAT cycle. The product is hot and under extreme pressure.

When the heating cycle is complete, the machine will enter the STORAGE mode.

sanitizing solution (example: Kay-5[®] or Stera-Sheen[®]). Use warm water and follow the manufacturer's specifications.

Note: To assure sanitary conditions are maintained, brush clean each item for a total of 60 seconds, repeatedly dipping the brush in sanitizing solution.

2. Return to the freezer with a small amount of cleaning solution. Dip the door spout brush into the cleaning solution and brush clean the door spout and the bottom of the draw valve.
3. Using a clean, sanitized towel, wipe down the freezer door, front panel, the area around the bottom of the freezer door, and any other areas that demonstrate a build-up of either moisture or food substance. Install the front drip tray and splash shield.
4. When ready to resume normal operation, press the AUTO button.

Note: This procedure should be performed 15 minutes prior to serving product, if this is not pre-programmed.

Manual Brush Cleaning

These procedures must be completed according to the frequency specified by your Federal, State, or local regulatory agencies. Please consult your governing Food Code to determine the maximum number of days allowed between brush clean cycles.

ALWAYS FOLLOW LOCAL HEALTH CODES.

To disassemble these machine, the following items will be needed:

- Two cleaning and sanitizing pails
- Sanitizer/Cleaner
- Necessary brushes
- Single service towels

6

Daily Opening Procedures

Before performing the opening procedures, check the display panel for any error messages. If a fault has been detected, investigate the cause before proceeding with the opening procedures.

1. Prepare a small amount of an approved 100 PPM

Draining Product From the Barrel

1. With a pail beneath the door spout, open the draw valve to release the barrel pressure. Press the WASH button and wait for a few seconds.
2. Press the STOP button. Disconnect and remove the feed tube, the pump, and the hopper agitator.
3. Press the WASH button. Drain the product from the barrel and the mix hopper.
4. When the flow of product stops, press the STOP button. Close the draw valve. Properly dispose of the mix.

Rinsing

Note: *Do not brush clean the mix inlet hole while the machine is in the WASH mode.*

1. Pour 2 gallons (8.0 liters) of cool, clean water into the mix hopper. Using the hopper brush, scrub the mix hopper, mix level sensing probe, and the outside of the agitator drive shaft housing. Brush clean the mix inlet hole.

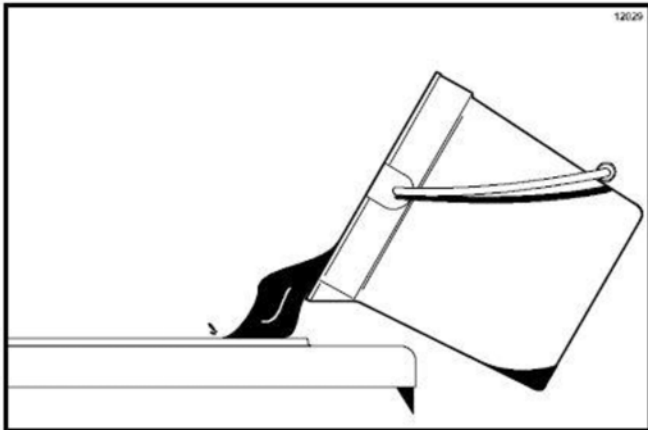

Figure 6-35

2. With a pail beneath the door spout, open the draw valve and press the WASH button.
3. Drain all the rinse water through the door spout. Close the draw valve and press the STOP button.
4. Repeat this procedure using clean, warm water, until the water being discharged is clear.

Hopper Cleaning

1. Prepare an approved 100 PPM sanitizing solution (example: 2-1/2 gal. [9.5 liters] of Kay-5[®] or 2 gal. [7.6 liters] of Stera-Sheen[®]). Use warm water and follow the manufacturer's specifications.
2. Pour the solution into the hopper and allow it to flow into the barrel.

Note: *Do not brush clean the mix inlet hole while the machine is in the WASH mode.*
3. Using the hopper brush, clean the mix hopper, mix level sensing probe, and the outside of the agitator drive shaft housing. Brush clean the mix inlet hole.
4. Press the WASH button. This will cause the cleaning solution in the barrel to come in contact with all areas of the barrel.
5. Place an empty pail beneath the door spout.
6. Open the draw valve on the freezer door and draw off all the solution.
7. Once the cleaning solution stops flowing from the door spout, close the draw valve and press the STOP button.

Disassembly

Note: *Failure to remove the parts specified in the following brush cleaning and lubrication procedures will result in damage to the machine. These parts must be removed within the maximum number of days allowed between brush clean cycles or the machine will hard lock and will not operate.*



WARNING! Make sure the power switch is in the OFF position! Failure to follow this instruction may result in severe personal injury to fingers or hands from hazardous moving parts.

1. Remove the handscrews, the freezer door, the beater and the scraper blades, and the drive shaft seal from the barrel.
2. Remove the scraper blades and the beater head from the beater.
3. Remove the drive shaft seal from the beater.

- Disassemble the pump. Remove the liquid regulator tube with the pump valve, the spring, and the O-ring. Remove the cover, the gears, and the O-rings. Remove the feed tube, the feed tube coupling, the duck-bill valve, and the O-rings.

Note: Never use any tool to remove the gears from the pump body.

- Disassemble the freezer door. Remove the door O-ring, pivot pin, draw valve, draw handle, counter-beater with bushings, and O-rings.
- Remove the front drip shelf, drip tray, and splash shield.
- Remove the drip pan.
- Take all parts to the sink for cleaning.

Note: If the drip pan is filled with an excessive amount of mix, it is an indication that the drive shaft seal should be replaced or properly lubricated.

Brush Cleaning

- Prepare an approved 100 PPM sanitizing solution (example: 2-1/2 gal [9.5 liters] of Kay-5[®] or 2 gal. [7.6 liters] of Stera-Sheen[®]). Use warm water and follow the manufacturer's specifications.
- Thoroughly brush clean all disassembled parts in the cleaning solution, making sure all lubricant and mix film is removed. Be sure to brush all surfaces and holes, especially the holes in the pump components and the draw valve hole in the freezer door.
Place the parts on a clean, dry surface to air dry overnight.
- Return to the freezer with a small amount of cleaning solution. Using a brush, clean the drive shaft opening at the back of the freezing cylinder.
- Using the brush, clean the mix pump drive hub opening in the rear wall of the mix hopper.
- Wipe all exterior surfaces of the freezer with a clean, sanitized towel.

Adjustments

For best performance carefully read the following instructions before proceeding.

Consistency Adjustment

- With the machine filled with fresh mix, touch the AUTO button to start the freezing cycle.

Note: The freezing cycle will start with the last programmed consistency value.

- Press the AUTO and OPTION buttons simultaneously for a few seconds until the adjustment menu appears on the display.



Figure 6-36

- The first menu item allows the operator to adjust the consistency of the product by setting a number on a scale from 60 to 250. Low numbers correspond to low product consistency, high numbers correspond to high product consistency.

Press the UP ARROW button to increase the value; press the DOWN ARROW button to decrease the value.

CONSISTENCY	180
COLD STORAGE	4°C
MIXING ON	10 sec
MIXING OFF	5 min

Figure 6-37

- Press OK button to confirm the new selected value. Press C button to erase the new value.
- Press the OK button to confirm the other menu items and exit the menu by saving the changes.

Hopper Temperature Adjustment in AUTO Mode

1. With a machine loaded with fresh mix, touch the AUTO button to start with the freezing cycle.
2. Press the AUTO and OPTION buttons simultaneously for a few seconds until the adjustment menu appears on the display.

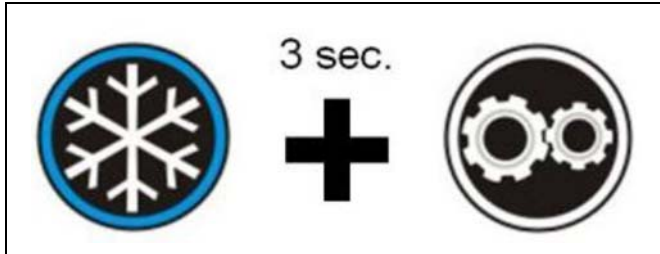

Figure 6-38

3. The first menu item allows the operator to adjust the consistency of the product. Touch the OK button to confirm the displayed value and switch to the next entry.
4. Subsequent parameters allow the operator to change the temperature of the mix in the hopper during the AUTO mode between 32°F (0°C) and 41°F (5°C).
5. Press the UP ARROW button to increase the temperature; press the DOWN ARROW button to decrease the temperature.

CONSISTENCY	180
COLD STORAGE	4°C
MIXING ON	10 sec
MIXING OFF	5 min

Figure 6-39

6. Press OK button to confirm the new selected value. Press C button to erase the new value.
7. Press the OK button to confirm the other menu items and exit the menu.
8. Press the OK button to confirm the other menu items and exit the menu by saving the changes.

Hopper Agitation Adjustment in AUTO Mode

1. With the machine filled with fresh mix, press the AUTO button to start the freezing cycle.
2. Press the AUTO and OPTION buttons simultaneously for a few seconds until the adjustment menu appears on the display.

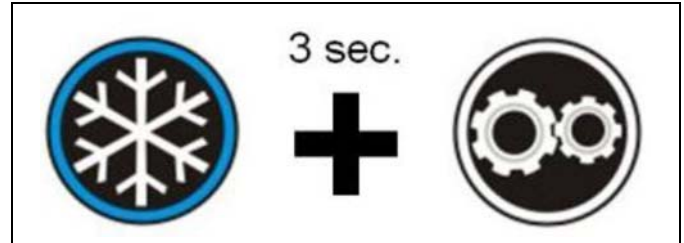

Figure 6-40

3. The first menu item allows you to adjust the consistency of the product. Touch the OK button to confirm the displayed value and switch to the next entry.
4. Subsequent parameters allow the operator to change the operating times (MIXING ON) and pause (MIXING OFF) of the hopper agitator motor during the AUTO mode.

CONSISTENCY	180
COLD STORAGE	4°C
MIXING ON	10 sec
MIXING OFF	5 min

Figure 6-41

5. Press the UP ARROW button to increase the time; press the DOWN ARROW button to decrease the time.
6. Press OK button to confirm the new selected values. Press C button to erase the new values.

Hopper Temperature Adjustment in STANDBY Mode

1. With the machine filled with a fresh mix, press the STANDBY button.
2. Press the STAND BY and OPTION buttons simultaneously for a few seconds until the adjustment menu appears on the display.



Figure 6-42

3. The first menu item allows the operator to change the temperature of the mix in the hopper during the STANDBY mode between 32°F (0°C) and 41°F (5°C).

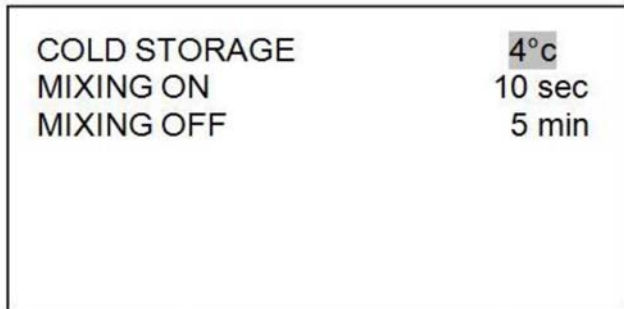

Figure 6-43

4. Press the UP ARROW button to increase the temperature; press the DOWN ARROW button to decrease the temperature.
5. Press OK button to confirm the new selected value. Press C button to erase the new value.
6. Press the OK button to confirm the other menu items and exit the menu by saving the changes.

Hopper Agitation Adjustment in STANDBY Mode

1. With the machine filled with fresh mix, press the STANDBY button.
2. Press the STANDBY and OPTION buttons simultaneously for a few seconds until the adjustment menu appears on the display.



Figure 6-44

3. The first menu item allows you to adjust the temperature of the product in STANDBY mode. Press the OK button to confirm the displayed value and switch to the next entry.
4. Subsequent parameters allow the operator to change the operating times (MIXING ON) and pause (MIXING OFF) of the hopper agitator motor during the STANDBY mode.

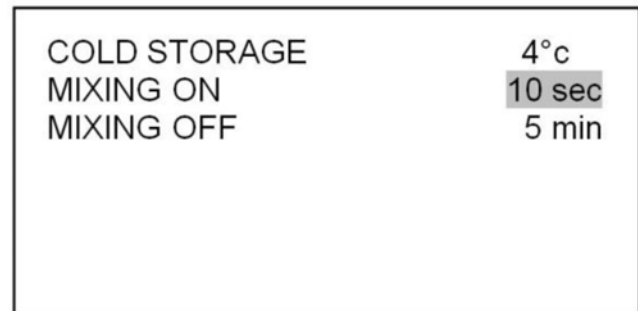

Figure 6-45

5. Press the UP ARROW button to increase the time; press the DOWN ARROW button to decrease the time.
6. Press the OK button to confirm the new selected value. Press C button to erase the new value.
7. Press the OK button to confirm the other menu items and exit the menu by saving the changes.

During Cleaning and Sanitizing



ALWAYS FOLLOW LOCAL HEALTH CODES.

Cleaning and sanitizing schedules are governed by federal, state, or local regulatory agencies, and must be followed accordingly. If the machine has a Standby mode, it must not be used in lieu of proper cleaning and sanitizing procedures and frequencies set forth by the ruling health authority.

The following check points should be stressed during the cleaning and sanitizing operations:



IMPORTANT! Cleaning and sanitizing must be performed daily.

Troubleshooting Bacterial Count

- Thoroughly clean and sanitize the machine regularly, including complete disassembly and brush cleaning.
 - Use all brushes supplied for thorough cleaning. The brushes are specially designed to reach all mix passageways.
 - Use the middle-size brush to clean the mix inlet hole which extends from the mix hopper down to the rear of the barrel.
 - Use the smaller brush to clean the drive hub opening in the rear wall of the mix hopper. Make sure there is a generous amount of cleaning solution on the brush.
 - Use the smaller, white bristle brush to clean the mix inlet hole that extends from the mix hopper down to the rear of the freezing cylinder.
 - Use the black bristle brush to thoroughly clean the shell bearing located at the rear of the freezing cylinder. Make sure to have a generous amount of cleaning solution on the brush.
- If local health codes permit the use of rerun, make sure the mix rerun is stored in a sanitized, covered stainless steel container and is used the following day. **Do not** prime the machine with rerun. When using rerun, skim the foam and discard it. Mix the rerun with fresh mix in a ratio of 50:50 during the day's operation.
 - On a designated day of the week, run the mix as low as feasible and discard after closing. This will break the rerun cycle and reduce the possibility of high bacteria and coliform counts.
 - Properly prepare the cleaning and sanitizing solutions. Read and follow label directions carefully. **Too strong of a solution may damage the parts, and too weak of a solution will not do an adequate job of cleaning or sanitizing.**
 - The temperature of the mix in the mix hopper and walk-in cooler should be below 40°F (4.4°C).
 - Discard remaining mix from the freezer during "Cleaning Procedures."

Regular Maintenance Checks

- Replace scraper blades that are nicked or damaged. Before installing the beater assembly, be certain that scraper blades are properly attached to the beater.
- Using a screwdriver and cloth towel, keep the rear shell bearing and the female hex drive socket clean and free of lubricant and mix deposits.
- Dispose of O-rings or seals if they are worn, torn, or fit too loosely, and replace them with new ones.
- Follow all lubricating procedures as outlined in "Assembly" on page 6-1.
- If your machine is air-cooled, check the condenser for an accumulation of dirt and lint. A dirty condenser will reduce the efficiency and capacity of the machine. Condensers should be cleaned **monthly** with a soft brush. **Never** use screwdrivers or other metal probes to clean between the fins.

OPERATOR CHECKLIST

Note: For machines equipped with an air filter, it will be necessary to vacuum clean the filters on a monthly schedule.



WARNING! Always disconnect electrical power prior to cleaning the condenser. Failure to follow this instruction may result in electrocution.

- If your machine is equipped with an auxiliary refrigeration system, check the auxiliary condenser for accumulation of dirt and lint. A dirty condenser will reduce the refrigeration capacity of the mix hopper. Condensers must be cleaned **monthly** with a soft brush. **Never** use screwdrivers or other metal probes to clean between the fins. Failure to comply may result in electrocution.
- If your machine is water-cooled, check the water lines for kinks or leaks. Kinks can occur when the machine is moved back and forth for cleaning or maintenance purposes. Deteriorated or cracked water lines should be replaced only by a Taylor service technician.

Winter Storage

It is recommended that an authorized service technician perform winter storage draining, to insure all water has been removed. This will guard against freezing and rupturing of the components.

If the place of business is to be closed during the winter months, it is important to protect the freezer by following certain precautions, particularly if the building is subject to freezing conditions.

Important! On water-cooled freezers, disconnect the water supply. Relieve pressure on the spring in the water valve. Use air pressure on the outlet side to blow out any water remaining in the condenser. **This is extremely important.** Failure to follow this procedure may cause severe and costly damage to the refrigeration system. Your local Taylor distributor can perform this service for you.

- Disconnect the freezer from the main power source to prevent possible electrical damage.
- Wrap detachable parts of the freezer, such as the beater assembly and freezer door, and place them in a protected dry place. Rubber trim parts and gaskets can be protected by wrapping them with moisture-proof paper.
- All parts should be thoroughly cleaned of dried mix or lubrication accumulations, which attract mice and other vermin.

Table 8-1

Problem	Probable Cause	Remedy	Page Ref.
1. Soft lock message appears on display.	<ul style="list-style-type: none"> a. More than 24 hours since the last HEAT cycle. b. The freezer was not in the AUTO or STANDBY mode when the heat cycle was programmed to start. c. The hopper agitator is not installed. d. There was a power failure. 	<ul style="list-style-type: none"> a. The freezer must go through a HEAT cycle every 24 hours. The freezer must now be disassembled and brush cleaned or placed in a heat cycle. b. The freezer must be in the AUTO or STANDBY mode. The freezer must now be disassembled and brush cleaned or placed in a heat cycle. c. The hopper agitator must be cleaned and installed before starting the HEAT cycle. The freezer must now be disassembled and brush cleaned or placed in a heat cycle. d. Check the Event History fault messages. Disassemble and brush clean, or initiate a heat treatment cycle. 	<p>---</p> <p>5-4 and 6-10</p> <p>5-4 and 6-10</p> <p>5-7</p>
2. Hard lock message appears on display.	<ul style="list-style-type: none"> a. Brush cleaning interval exceeded. 	<ul style="list-style-type: none"> a. The freezer must be disassembled and brush cleaned within 24 hours when the counter indicates one day remaining. 	6-10
3. No control panel functions with machine connected to the power supply.	<ul style="list-style-type: none"> a. Circuit breaker OFF or blown fuse. b. Blown main board fuses. 	<ul style="list-style-type: none"> a. Turn the breaker ON or replace the fuse. b. Call an authorized service technician. 	<p>---</p> <p>---</p>
4. Machine makes a squealing noise	<ul style="list-style-type: none"> a. Starved barrel. 	<ul style="list-style-type: none"> a. Remove, clean, and reinstall the pump. b. Check, and if necessary, change the position of the regulator tube on position for greater liquid flow (turn it to the left). 	<p>6-5</p> <p>---</p>
5. No product is being dispensed	<ul style="list-style-type: none"> a. Low on mix. The "LEVEL" signal is on. b. Machine not in AUTO mode. c. Beater motor is off during over temperature. The message appears on the display. 	<ul style="list-style-type: none"> a. Add mix to the hopper. b. Select AUTO and allow machine to cycle off before drawing product. c. Press the STOP button and wait 5 minutes. Restart the machine in AUTO. 	<p>---</p> <p>5-2</p> <p>5-2</p>
6. The product is too soft.	<ul style="list-style-type: none"> a. The viscosity control is set too warm. b. The scraper blades are worn. 	<ul style="list-style-type: none"> a. Increase the consistency values. b. Replace the scraper blades with new ones. 	<p>---</p> <p>6-1</p>

TROUBLESHOOTING GUIDE

Problem	Probable Cause	Remedy	Page Ref.
7. The product is too thick.	a. The viscosity control is set too cold.	a. Decrease the consistency values.	6-12
	b. Barrel not primed correctly.	b. Drain the barrel and prime the machine.	6-8
	c. Mix pump incorrectly assembled.	c. Follow assembly procedures carefully.	6-5
	d. Mix pump incorrectly set.	d. Check and, if necessary, change the position of the regulator tube.	6-5
	e. Butterfat is in the pump.	e. Disassemble, clean, and reinstall the pump.	6-5
8. The mix in the hopper is too warm.	a. Hopper cover is not in position.	a. Clean and sanitize the hopper cover and place it in position.	6-11
	b. The agitator is not installed.	b. Clean and sanitize the agitator and install it.	---
	c. The hopper temperature control is set too warm.	c. Decrease the temperature value in the menu.	6-13 and 6-14
	d. Defective thermistor probe.	d. Call an authorized service technician.	---
9. The mix in the hopper is too cold.	a. The hopper temperature control is set too cold.	a. Increase the temperature value in the menu.	6-13 and 6-14
	b. Defective Thermistor probe.	b. Call an authorized service technician.	---
10. Mix low and mix out probes are not functioning.	a. Milk stone or foam build-up in the hopper.	a. Clean hopper thoroughly.	6-11
11. Product is collecting on top of the freezer door.	a. The top O-ring on draw valve is improperly lubricated or worn.	a. Lubricate or replace the O-ring.	6-2
12. Excessive mix leakage from the bottom of door spout.	a. Bottom O-ring on the draw valve is improperly lubricated or worn.	a. Lubricate or replace the O-ring.	6-2
13. Excessive mix leakage into the long drip pan.	a. Beater shaft seal improperly lubricated or worn.	a. Lubricate or replace the seal.	---
14. The barrel walls are scored.	a. Missing or worn beater auger.	a. Install or replace the beater head.	6-1
	b. Missing or worn scraper blades.	b. Install or replace the scraper blades.	6-1
	c. Missing or worn counter beater.	c. Install or replace the counter beater.	6-1
	d. The machine was placed in AUTO before all sanitizing solution was removed from barrel.	d. Place machine in AUTO only after priming is complete and all sanitizing solution is removed.	5-2
	e. Beater assembly is bent.	e. Replace beater assembly.	6-1
	f. Counter-beater assembly is bent.	f. Replace counter-beater assembly.	6-1
15. The product makes a popping sound when drawing product.	a. Pump assembled incorrectly.	a. Assemble and lubricate according to instructions in this manual.	6-5
	b. Air/mix pump incorrectly setted.	b. Check and, if necessary, change the position of the regulator tube to a position with greater liquid flow (turn it to the left).	---
	c. Draw rate is set too fast.	c. Adjust draw rate.	---
	d. Barrel not primed correctly.	d. Drain the barrel and prime the machine.	6-8

Maintenance Intervals

Table 9-1

Part Description	Every 3 Months	Every 6 Months	Annually	Every 4 Years
Door Assembly				X
Scraper Blades			X	
Beater Head			X	
Beater Drive Shaft Seal		X		
Freezer Door O-Rings		X		
Draw Valve O-Ring		X		
Feed Tube O-Rings		X		
Pump O-Rings		X		
Duck Bill Valve		X		
Pump Rubber Valve		X		
Pump Gears			X	
Mix Pump Actuator Belt			X	
Glycol Fluid				X
Brush-Drive Hub		Inspect and replace if necessary.	Minimum	
Brush-Mix Inlet		Inspect and replace if necessary.	Minimum	
Brush-Hopper		Inspect and replace if necessary.	Minimum	

TAYLOR COMPANY LIMITED WARRANTY ON FREEZERS

Taylor Company, is pleased to provide this limited warranty on new Taylor-branded freezer machines available from Taylor to the market generally (the "Product") to the original purchaser only.

LIMITED WARRANTY

Taylor warrants the Product against failure due to defects in materials or workmanship under normal use and service as follows. All warranty periods begin on the date of original Product installation. If a part fails due to defects during the applicable warranty period, Taylor, through a Taylor-authorized Taylor distributor or service agency, will provide a new or re-manufactured part, at Taylor's option, to replace the failed defective part at no charge for the part. Except as otherwise stated herein, these are Taylor's exclusive obligations under this limited warranty for a Product failure. This limited warranty is subject to all provisions, conditions, limitations, and exclusions listed below and on the reverse (if any) of this document.

Table 10-1

Product	Part	Limited Warranty Period
Soft Serve	Insulated Shell Assembly	Three (3) Years
	Refrigeration Compressor (except service valve)	Three (3) Years
	Beater Motors	Two (2) Years
	Beater Drive Gear	Two (2) Years
	Printed Circuit Boards and Softech™ Controls	Two (2) Years
	Parts Not Otherwise Listed in This Table or Excluded Below	One (1) Years

LIMITED WARRANTY CONDITIONS

1. If the date of original installation of the Product cannot be verified, then the limited warranty period begins ninety (90) days from the date of Product manufacture (as indicated by the Product serial number). Proof of purchase may be required at time of service.
2. This limited warranty is valid only if the Product is installed and all required service work on the Product is performed by a Taylor-authorized distributor or service agency, and only if genuine, new Taylor parts are used.
3. Installation, use, care, and maintenance must be normal and in accordance with all instructions contained in the Taylor Operator's Manual.
4. Defective parts must be returned to the Taylor-authorized distributor or service agency for credit.
5. The use of any refrigerant other than that specified on the Product's data label will void this limited warranty.

LIMITED WARRANTY EXCEPTIONS

This limited warranty does **not** cover:

1. Labor or other costs incurred for diagnosing, repairing, removing, installing, shipping, servicing, or handling of defective parts, replacement parts, or new Products.
2. Normal maintenance, cleaning, and lubrication as outlined in the Taylor Operator's Manual, including cleaning of condensers.
3. Replacement of wear items designated as Class 000 parts in the Taylor Operator's Manual.
4. External hoses, electrical power supplies, and machine grounding.
5. Parts not supplied or designated by Taylor, or damages resulting from their use.
6. Return trips or waiting time required because a service technician is prevented from beginning warranty service work promptly upon arrival.
7. Failure, damage, or repairs due to faulty installation, misapplication, abuse, no or improper servicing, unauthorized alteration, or improper operation or use as indicated in the Taylor Operator's Manual, including but not limited to the failure to use proper assembly and cleaning techniques, tools, or approved cleaning supplies.
8. Failure, damage, or repairs due to theft, vandalism, wind, rain, flood, high water, water, lightning, earthquake, or any other natural disaster, fire, corrosive environments, insect or rodent infestation, or other casualty, accident, or condition beyond the reasonable control of Taylor; operation above or below the electrical or water supply specification of the Product; components repaired or altered in any way so as to, in the judgment of the Manufacturer, adversely affect performance, or normal wear or deterioration.
9. Any Product purchased over the Internet.
10. Failure to start due to voltage conditions, blown fuses, open circuit breakers, or damages due to the inadequacy or interruption of electrical service.
11. Electricity or fuel costs, or increases in electricity or fuel costs for any reason whatsoever.
12. Damages resulting from the use of any refrigerant other than that specified on the Product's data label will void this limited warranty.
13. Any cost to replace, refill, or dispose of refrigerant, including the cost of refrigerant.
14. **ANY SPECIAL, INDIRECT, OR CONSEQUENTIAL PROPERTY OR COMMERCIAL DAMAGE OF ANY NATURE WHATSOEVER.** Some jurisdictions do not allow the exclusion of incidental or consequential damages, so this limitation may not apply to you.

This limited warranty gives you specific legal rights, and you may also have other rights that vary from jurisdiction to jurisdiction.

LIMITATION OF WARRANTY

THIS LIMITED WARRANTY IS EXCLUSIVE AND IS IN LIEU OF ALL OTHER WARRANTIES, CONDITIONS, AND/OR REMEDIES UNDER THE LAW, INCLUDING ANY IMPLIED WARRANTIES OR CONDITIONS OF MERCHANTABILITY OR FITNESS FOR A PARTICULAR PURPOSE. THE ORIGINAL OWNER'S SOLE REMEDY WITH RESPECT TO ANY PRODUCTS SHALL BE REPAIR OR REPLACEMENT OF DEFECTIVE COMPONENTS UNDER THE TERMS OF THIS LIMITED WARRANTY. ALL RIGHTS TO CONSEQUENTIAL OR INCIDENTAL DAMAGES (INCLUDING CLAIMS FOR LOST SALES, LOST PROFITS, PRODUCT LOSS, PROPERTY DAMAGES, OR SERVICE EXPENSES) ARE EXPRESSLY EXCLUDED. THE EXPRESS WARRANTIES MADE IN THIS LIMITED WARRANTY MAY NOT BE ALTERED, ENLARGED, OR CHANGED BY ANY DISTRIBUTOR, DEALER, OR OTHER PERSON, WHATSOEVER.

LEGAL REMEDIES

The owner **must** notify Taylor in writing by certified or registered letter to the following address of any defect or complaint with the Product, stating the defect or complaint and a specific request for repair, replacement, or other correction of the Product under warranty, mailed at least thirty (30) days before pursuing any legal rights or remedies.

Taylor Company
750 N. Blackhawk Blvd.
Rockton, IL 61072, U.S.A.

TAYLOR COMPANY LIMITED WARRANTY ON GENUINE TAYLOR PARTS

Taylor Company, is pleased to provide this limited warranty on genuine, new Taylor genuine replacement components and parts available from Taylor to the market generally (the “Parts”) to the original purchaser only.

LIMITED WARRANTY

Taylor warrants the Parts against failure due to defect in materials or workmanship under normal use and service as follows. All warranty periods begin on the date of original installation of the Part in the Taylor product. If a Part fails due to defects during the applicable warranty period, Taylor, through an authorized Taylor distributor or service agency, will provide a new or remanufactured Part, at Taylor's option to replace the failed defective Part at no charge for the Part. Except as otherwise stated herein, these are Taylor's exclusive obligations under this limited warranty for a Part failure. This limited warranty is subject to all provisions, conditions, limitations, and exclusions listed below and on the reverse (if any) of this document.

Table 11-1

Part's Warranty Class Code or Part	Limited Warranty Period
Class 103 Parts ¹	Three (3) Months
Class 212 Parts ²	Twelve (12) Months
Class 512 Parts	Twelve (12) Months
Class 000 Parts	No Warranty
Taylor Part #072454 (Motor-24VDC *C832/C842*)	Four (4) Years

LIMITED WARRANTY CONDITIONS

1. If the date of original installation of the Part cannot be otherwise verified, proof of purchase may be required at time of service.
2. This limited warranty is valid only if the Part is installed and all required service work in connection with the Part is performed by a Taylor-authorized distributor or service agency.
3. The limited warranty applies only to Parts remaining in use by their original owner at their original installation location in the machine of original installation.
4. Installation, use, care, and maintenance must be normal and in accordance with all instructions contained in the Taylor Operator's Manual.
5. Defective Parts must be returned to the Taylor-authorized distributor or service agency for credit.
6. This warranty is not intended to shorten the length of any warranty coverage provided pursuant to a separate Taylor limited warranty on freezer or grill products.
7. The use of any refrigerant other than that specified for the machine in which the Part is installed will void this limited warranty.

^{1, 2} Except that Taylor Part #032129SER2 (Compressor-Air-230V SERV) and Taylor Part #075506SER1 (Compressor-Air-115V 60HZ) shall have a limited warranty period of twelve (12) months when used in Taylor freezer machines and a limited warranty period of two (2) years when used in Taylor grill machines.

LIMITED WARRANTY ON PARTS

LIMITED WARRANTY EXCEPTIONS

This limited warranty does **not** cover:

1. Labor or other costs incurred for diagnosing, repairing, removing, installing, shipping, servicing, or handling of defective Parts, replacement Parts, or new Parts.
2. Normal maintenance, cleaning, and lubrication as outlined in the Taylor Operator's Manual, including cleaning of condensers or carbon and grease buildup.
3. Required service, whether cleaning or general repairs, to return the cooking surface assemblies, including the upper platen and lower plate, to an operational condition to achieve proper cooking or allow proper assembly of release sheets and clips as a result of grease buildup on the cooking surfaces, including but not limited to the platen and plate, sides of the shroud, or top of the shroud.
4. Replacement of cooking surfaces, including the upper platen and lower plate, due to pitting or corrosion (or in the case of the upper platen, due to loss of plating) as a result of damage due to the impact of spatulas or other small wares used during the cooking process or as a result of the use of cleaners, cleaning materials, or cleaning processes not approved for use by Taylor.
5. Replacement of wear items designated as Class 000 Parts in the Taylor Operator's Manual, as well as any release sheets and clips for the Product's upper platen assembly.
6. External hoses, electrical power supplies, and machine grounding.
7. Parts not supplied or designated by Taylor, or damages resulting from their use.
8. Return trips or waiting time required because a service technician is prevented from beginning warranty service work promptly upon arrival.
9. Failure, damage, or repairs due to faulty installation, misapplication, abuse, no or improper servicing, unauthorized alteration or improper operation or use as indicated in the Taylor Operator's Manual, including but not limited to the failure to use proper assembly and cleaning techniques, tools, or approved cleaning supplies.
10. Failure, damage or repairs due to theft, vandalism, wind, rain, flood, high water, water, lightning, earthquake, or any other natural disaster, fire, corrosive environments, insect or rodent infestation, or other casualty, accident or condition beyond the reasonable control of Taylor; operation above or below the gas, electrical, or water supply specification of the machine in which a part is installed; Parts or the machines in which they are installed repaired or altered in any way so as to, in the judgment of Taylor, adversely affect performance, or normal wear or deterioration.
11. Any Part purchased over the Internet.
12. Failure to start due to voltage conditions, blown fuses, open circuit breakers, or damages due to the inadequacy or interruption of electrical service.
13. Electricity, gas, or other fuel costs, or increases in electricity or fuel costs for any reason whatsoever.
14. Damages resulting from the use of any refrigerant other than that specified for the machine in which the Part is installed.
15. Any cost to replace, refill, or dispose of refrigerant, including the cost of refrigerant.
16. **ANY SPECIAL, INDIRECT, OR CONSEQUENTIAL PROPERTY OR COMMERCIAL DAMAGE OF ANY NATURE WHATSOEVER.** Some jurisdictions do not allow the exclusion of incidental or consequential damages, so this limitation may not apply to you.

This limited warranty gives you specific legal rights, and you may also have other rights which vary from jurisdiction to jurisdiction.

LIMITATION OF WARRANTY

THIS LIMITED WARRANTY IS EXCLUSIVE AND IS IN LIEU OF ALL OTHER WARRANTIES, CONDITIONS, AND/OR REMEDIES UNDER THE LAW, INCLUDING ANY IMPLIED WARRANTIES OR CONDITIONS OF MERCHANTABILITY OR FITNESS FOR A PARTICULAR PURPOSE. THE ORIGINAL OWNER'S SOLE REMEDY WITH RESPECT TO ANY PRODUCTS SHALL BE REPAIR OR REPLACEMENT OF DEFECTIVE PARTS UNDER THE TERMS OF THIS LIMITED WARRANTY. ALL RIGHTS TO CONSEQUENTIAL OR INCIDENTAL DAMAGES, (INCLUDING CLAIMS FOR LOST SALES, LOST PROFITS, PRODUCT LOSS, PROPERTY DAMAGES OR SERVICE EXPENSES) ARE EXPRESSLY EXCLUDED. THE EXPRESS WARRANTIES MADE IN THIS LIMITED WARRANTY MAY NOT BE ALTERED, ENLARGED, OR CHANGED BY ANY DISTRIBUTOR, DEALER, OR OTHER PERSON, WHATSOEVER.

LEGAL REMEDIES

The owner **must** notify Taylor in writing by certified or registered letter to the following address of any defect or complaint with the Part, stating the defect or complaint and a specific request for repair, replacement, or other correction of the Part under warranty, mailed at least thirty (30) days before pursuing any legal rights or remedies.

Taylor Company
750 N. Blackhawk Blvd.
Rockton, IL 61072, U.S.A.

